

TM 11-5815-332-15

TECHNICAL MANUAL

OPERATOR'S, ORGANIZATIONAL, DS, GS,
AND DEPOT MAINTENANCE MANUAL

RADIO TELETYPEWRITER SET
AN/VSC-3

(NSN 5815-00-788-8540)

This copy is a reprint which includes current
pages from Changes 1 through 10. w/chg 11 and 12

HEADQUARTERS, DEPARTMENT OF THE ARMY

JANUARY 1971

WARNING

DANGEROUS VOLTAGES EXIST IN THIS EQUIPMENT

Voltages as high as 128 volts ac, 3,000 volts dc, and 10,000 volts RF are used in the operation of Amplifier Radio Frequency AM-3349 / GRC-106.

Dangerous high RF voltages exist at the antenna of Amplifier Radio Frequency AM-3349 / GRC-106. DO NOT use the whip antenna on the front roadside of the M577A1 Vehicle as a handhold. Death or serious injury may result from touching the antenna when the radio set is operated.

CHANGE }
No. 10 }

HEADQUARTERS
DEPARTMENT OF THE ARMY
WASHINGTON, DC 15 JULY 1981

**Operator's, Organizational, Direct Support,
General Support, and Depot Maintenance Manual
RADIO TELETYPEWRITER SET AN/VSC-3 (NSN 5815-00-788-8540)
AND
RADIO TELETYPEWRITER SET AN/VSC-3A (NSN 5815-01-102-5916)**

TM 11-5815-332-15, 14 January 1971, is changed as follows:

1. The title of the manual is changed as shown above.
2. New or changed material is indicated by a vertical bar.
3. Remove and insert pages as indicated below:

Remove	Insert
i and ii	i and ii
1-1 through 1-2	1-1 through 1-2
1-3	1-3 and 1-4
1-5 and 1-6	1-5 and 1-6
3-7 through 3-8.2	3-7 through 3-8.3
4-1 and 4-2	4-1 and 4-2
7-7 through 7-10	7-7 through 7-10
A-1 and A-2	A-land A-2
B-3 through B-5	B-3 through B-5/(B-6 blank)
C-5 and C-6	C-5 and C-6
E-1 and E-2	E-land E-2
None	Figure FO 2-11

4. File this change sheet in front of the publication for reference purposes.

By Order of the Secretary of the Army:

E. C. MEYER
General, United States Army
Chief of Staff

Official:

ROBERT M JOYCE
Brigadier General, United States Army
The Adjutant General

Distribution:

To be distributed in accordance with DA Form 12-51, Operator maintenance requirements for ANIVSC-3.

CHANGE

No. 11

HEADQUARTERS
DEPARTMENT OF THE ARMY
Washington, DC, 15 July 1989

**OPERATOR'S, ORGANIZATIONAL, DIRECT SUPPORT,
GENERAL SUPPORT AND DEPOT MAINTENANCE MANUAL**

**RADIO TELETYPEWRITER SET AN/VSC-3 (NSN 5815-00-224-8130)
AN/VSC-3A (NSN 5815-01-102-5916), AN/VSC-3 (With MK-2488/G), AND
AN/VSC-3A (with MK-2488/G)**

TM 11-5815-332-15, 14 January 1971, is changed as follows:

1. Title of manual is changed as shown above.
2. Remove old pages and insert new pages as indicated below. New or changed material is indicated by a vertical bar in the margin of the page. Added or revised illustrations are indicated by a vertical bar adjacent to the identification number.

<i>Remove pages</i>	<i>Insert pages</i>
i and ii	i through iii/(iv blank)
1-1 through 1-2.1/(1-2.2 blank)	1-1 and 1-2
1-3 through 1-6	1-3 through 1-6
1-11 and 1-12	1-11 and 1-12
1-15 and 1-16	1-15 and 1-16
2-1 through 2-4	2-1 through 2-4
None	2-4.1 and 2-4.2
2-5 and 2-6	2-5 and 2-6
None	2-6.1 through 2-6.4
3-7 through 3-8.3	3-7 through 3-8.4
5-1 and 5-2	5-1 and 5-2
6-1 and 6-2	6-1 through 6-4
7-1 and 7-2	7-1 and 7-2
None	7-8.1/(7-8.2 blank)
7-15 and 7-16	7-15 and 7-16
A-1 and A-2	A-1 and A-2
C-1 through C-6	C-1 through C-6
D-1 and D-2	D-1 and D-2

3. File this change sheet in the front of the publication for reference purposes.

Distribution authorized to the Department of Defense and DOD contractors only for official use or for administration or operational purposes. This determination was made on 20 March 1989. Other requests for this document will be referred to Commander, US Army Communications-Electronics Command and Fort Monmouth, ATTN: AMSEL-LC-ME-P, Fort Monmouth, NJ 07703-5000.

DESTRUCTION NOTICE—Destroy by any method that will prevent disclosure of contents or reconstruction of the document.

By Order of the Secretary of the Army:

CARL E. VUONO
General, United States Army
Chief of Staff

Official:

WILLIAM J. MEEHAN II
Brigadier General, United States Army
The Adjutant General

DISTRIBUTION:

To be distributed in accordance with DA Form 12-51 Operator, Unit,
and DS/GS requirements for AN/VSC-3,3A.

TM 11-5815-332-15
C 1 2

Change
No. 12

HEADQUARTERS,
DEPARTMENT OF THE ARMY
Washington, DC, 15 September 1989

OPERATOR'S, ORGANIZATIONAL, DIRECT SUPPORT
GENERAL SUPPORT, AND DEPOT MAINTENANCE MANUAL

RADIO TELETYPEWRITER SET AN/VSC-3 (NSN 5815-00-788-8540)

AND

RADIO TELETYPEWRITER SET AN/VSC-3A (NSN 5815-01-102-5916)

TM 11-5815-332-15, 14 January 1971, is changed as follows:

1. Remove old pages and insert new pages as indicated below. New or changed material is indicated by a vertical bar in the margin of the page.

Remove pages

4-1 and 4-2

Insert pages

4-1 through 4-11/(4-12 blank)

2. File this change sheet in the front of the publication for reference purposes.

Distribution authorized to the Department of Defense and DOD contractors only for official use or for administration or operational purposes. This determination was made on 15 May 1989. Other requests for this document will be referred to Commander, US Army Communications-Electronics Command and Fort Monmouth, ATTN: AMSEL-LC-ME-P, Fort Monmouth, NJ 07703-5000.

DESTRUCTION NOTICE— Destroy by any method that will prevent disclosure of contents or reconstruction of the document.

By Order of the Secretary of the Army:

Official:

CARL E. VUONO
General, United States Army
Chief of Staff

WILLIAM J. MEEHAN II
Brigadier General, United States Army
The Adjutant General

DISTRIBUTION:

To be distributed in accordance with DA Form 12-51 operator,
unit, and DS/GS requirements for AN/VSC-3A.

WARNING RADIATION HAZARD

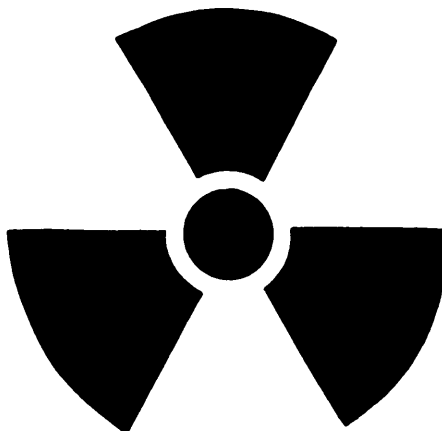

**RADIOACTIVE MATERIAL
CONTROLLED DISPOSAL REQUIRED
ACCOUNTABILITY NOT REQUIRED**

STD RW -2

Meter	Ra 226	1.0uCi	6625-00-257-1103
Meter	Ra 226	0.6uCi	6625-00-226-5680
Meter arbitrary scale	Ra 226	1.0uCi	6625-00-226-5679
Meter, arbitrary scale	Ra 226	1.0uCi	6625-00-226-5681

Radiation Hazard Information: The following radiation hazard information must be read and understood by all personnel operating or repairing Radio Teletypewriter Set AN/VSC-3. Hazardous radioactive materials are present in the above listed components of the MD-522/GRC, RT-662/GRC, RT-834/GRC, and the AM-3349/GRC. The components are potentially hazardous when broken. See qualified medical personnel and the local Radiological Protection Officer (RPO) immediately if you are exposed to or cut by broken components. First aid instructions are contained in TB 43-0116, TB 43-0122, and AR 755-15. NEVER place radioactive components in your pocket.

Use extreme care NOT to break radioactive components while handling them.

NEVER remove radioactive components from cartons until you are ready to use them.

If any of these components are broken, notify the local RPO immediately. The RPO will survey the immediate area for radiological contamination and will supervise the removal of broken components. The above listed radioactive components *will not* be repaired or disassembled.

Disposal of broken, unserviceable, or unwanted radioactive components will be accomplished in accordance with the instructions in AR 755-15.

WARNING

SERIOUS INJURY OR EVEN DEATH CAN HAPPEN IF THE FOLLOWING ARE NOT CAREFULLY OBSERVED WHEN INSTALLING AND USING THE ANTENNAS USED WITH YOUR RADIO SETS.

**BEFORE ANY
MISSION FIND
OUT**

1. ARE THERE ANY POWERLINES IN YOUR AREA OF OPERATION?
2. HOW HIGH ARE THESE POWERLINES?
3. HOW TALL ARE THE POLES OR TOWERS CARRYING POWERLINES?

MOBILE OPERATION WITH WHIP ANTENNAS

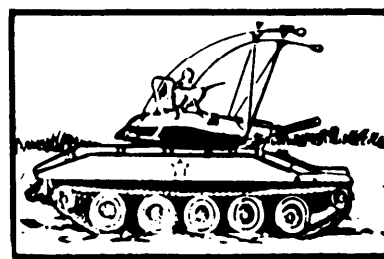
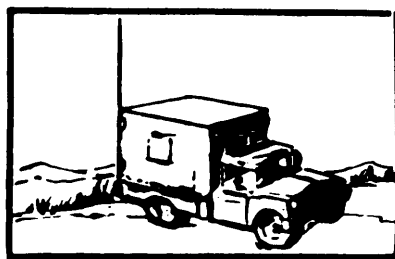
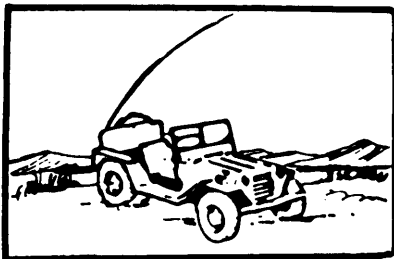

DO NOT STOP YOUR VEHICLE UNDER POWER LINES.

- IF POSSIBLE, TRY TO MAINTAIN MOBILE COMMUNICATIONS WITH YOUR ANTENNA(S) TIED DOWN.
- MAKE SURE AN ANTENNA TIP CAP IS SECURELY TAPED ON THE END OF EACH WHIP ANTENNA.
- DO NOT LEAN AGAINST OR TOUCH A WHIP ANTENNA WHILE THE TRANSMITTER IS ON.
- DURING CROSS-COUNTRY OPERATION, DO NOT ALLOW ANYONE TO STICK AN ARM, LEG OR WEAPON OVER THE SIDES OF THE VEHICLE. IF YOUR ANTENNA ACCIDENTALLY TOUCHES A POWERLINE AND A LEG, ARM OR WEAPON CONTACTS A DAMP BUSH OR THE GROUND. A SERIOUS OR FATAL ACCIDENT CAN HAPPEN.
- IF YOU ARE NOT SURE THAT AN ANTENNA ON YOUR VEHICLE WILL CLEAR A POWERLINE, STOP BEFORE YOU GET CLOSE TO THE POWERLINE AND EITHER CAREFULLY TIE DOWN THE ANTENNA OR REMOVE ANTENNA SECTIONS TO MAKE SURE THAT YOU CAN SAFELY DRIVE UNDER THE POWER LINE.

FIXED OPERATION WITH LONG RANGE ANTENNAS WARNING

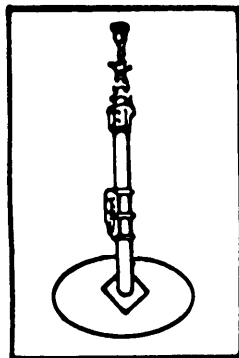

TELESCOPING ANTENNA
MAST

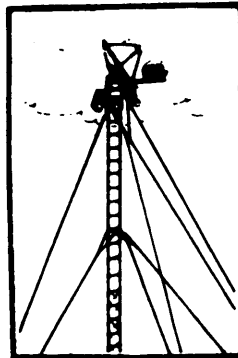

TYPICAL TOWER

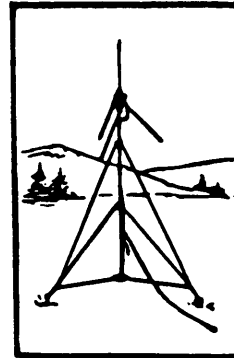

EXTENDED RANGE
ANTENNA

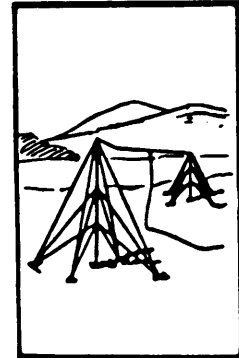

DOUBLET ANTENNA

NEVER ERECT THESE LONG RANGE ANTENNAS DIRECTLY UNDER POWER LINES.

IF YOU MUST ERECT THESE LONG RANGE ANTENNAS NEAR POWERLINES, POWERLINE POLES OR TOWERS, OR BUILDINGS WITH OVERHEAD POWERLINE CONNECTIONS, NEVER PUT THE ANTENNA CLOSER THAN TWO TIMES THE ANTENNA HEIGHT FROM THE BASE OF THE POWERLINE, POLE, TOWER OR BUILDINGS.

NEVER ATTEMPT TO ERECT ANY LONG RANGE ANTENNA WITHOUT A FULL TEAM.

BEFORE ERECTING ANY LONG RANGE ANTENNA, INSPECT ALL THE PARTS MAKING UP THE ANTENNA KIT. DO NOT ERECT THE ANTENNA IF ANY PARTS ARE MISSING OR DAMAGED.

DO AS MUCH OF THE ASSEMBLY WORK AS POSSIBLE ON THE GROUND.

WHEN ERECTING THE ANTENNA, ALLOW ONLY TEAM PERSONNEL IN THE ERECTION AREA.

MAKE SURE THAT THE AREA FOR THE ANCHORS IS FIRM. IF THE GROUND IS MARSHY OR SANDY, GET SPECIFIC INSTRUCTIONS FROM YOUR CREW CHIEF OR SUPERVISOR ON HOW TO REINFORCE THE ANCHORS.

WHEN SELECTING LOCATIONS FOR ANCHORS, AVOID TRAVELED AREAS AND ROADS. IF YOU CANNOT AVOID THESE AREAS, GET SPECIFIC INSTRUCTIONS FROM YOUR SUPERVISOR AS TO WHAT CLEARANCE YOUR GUY WIRES AND ROPES MUST HAVE OVER THE TRAVELED AREAS AND ROAD.

CLEARLY MARK ALL GUY WIRES AND ROPES WITH THE WARNING FLAGS OR SIGNS SUPPLIED BY YOUR UNIT. IN AN EMERGENCY, USE STRIPS OF WHITE CLOTH AS WARNING STREAMERS.

IF YOU SUSPECT THAT POWERLINES HAVE MADE ACCIDENTAL CONTACT WITH YOUR ANTENNA, STOP OPERATING ROPE OFF THE ANTENNA AREA AND NOTIFY YOUR SUPERIORS.

IF THE WEATHER IN YOUR AREA CAN CAUSE ICE TO FORM ON YOUR LONG RANGE ANTENNA AND ITS GUY WIRES AND ROPES, ADD EXTRA GUYS TO SUPPORT THE SYSTEM, ROPE OFF THE AREA AND POST IT WITH WARNING SIGNS LIKE "BEWARE OF FALLING ICE."

DO NOT TRY TO ERECT ANY ANTENNA DURING AN ELECTRICAL STORM.

KEEP A SHARP EYE ON YOUR ANCHORS AND GUYS. CHECK THEM DAILY AND IMMEDIATELY BEFORE AND AFTER BAD WEATHER.



5

SAFETY STEPS TO FOLLOW IF SOMEONE IS THE VICTIM OF ELECTRICAL SHOCK

1

DO NOT TRY TO PULL OR GRAB THE INDIVIDUAL

2

IF POSSIBLE , TURN OFF THE ELECTRICAL POWER

3

IF YOU CANNOT TURN OFF THE ELECTRICAL POWER, PULL, PUSH, OR LIFT THE PERSON TO SAFETY USING A WOODEN POLE OR A ROPE OR SOME OTHER INSULATING MATERIAL

4

SEND FOR HELP AS SOON AS POSSIBLE

5

AFTER THE INJURED PERSON IS FREE OF CONTACT WITH THE SOURCE OF ELECTRICAL SHOCK, MOVE THE PERSON A SHORT DISTANCE AWAY AND IMMEDIATELY START ARTIFICIAL RESUSCITATION

TECHNICAL MANUAL

No. 11-5815-332-15

HEADQUARTERS
DEPARTMENT OF THE ARMY
Washington, DC, 14 January 1971

**OPERATOR'S, ORGANIZATIONAL, DIRECT SUPPORT,
GENERAL SUPPORT AND DEPOT MAINTENANCE MANUAL
RADIO TELETYPEWRITER SET AN VSC-3 (NSN 5815-00-224-8130)
AND
RADIO TELETYPEWRITER SET AN/VSC-3A (NSN 5815-01-102-5916)
OR
RADIO TELETYPEWRITER SET AN/VSC-3 (With MK-2488/G)
AND
RADIO TELETYPEWRITER SET AN/VSC-3A (With MK-2488/G)**

REPORTING ERRORS AND RECOMMENDING IMPROVEMENTS

You can help improve this manual. If you find any mistakes or if you know of a way to improve the procedures, please let us know. Mail your letter, DA Form 2028 (Recommended Changes to Publications and Blank Forms), or DA Form 2028-2 located in back of this manual direct to: Commander, US Arm Communications-Electronics Command and Fort Monmouth, ATTN: AMSEL-LC-ME-PS, Fort Monmouth, NJ 07703-5000.

In either case, a reply will be furnished direct to you.

	Paragraph	Page
CHAPTER 1. LIST OF ILLUSTRATIONS		ii
INTRODUCTION		
SECTION I. General	1-1 - 1-3	1-1
II. Data and characteristics	1-4 - 1-5	1-1
III. Description	1-7 - 1-10	1-4
CHAPTER 2. INSTALLATION		
SECTION I. Service upon receipt of equipment	2-1, 2-2	2-1
II. Installation procedure	2-3 - 2-5	2-4
CHAPTER 3. OPERATING INSTRUCTIONS		
SECTION I. Controls and Indicators	3-1 - 3-6	3-1
II. Operating instructions	3-7 - 3-18	3-7
CHAPTER 4. OPERATOR'S MAINTENANCE INSTRUCTIONS	4-1 - 4-3	4-1
CHAPTER 5. ORGANIZATIONAL MAINTENANCE INSTRUCTIONS		
SECTION I. Organizational preventive maintenance check and services	5-1 - 5-3	5-1
II. Organizational troubleshooting and antenna mast sections replacement	5-4 - 5-5	
CHAPTER 6. CIRCUIT FUNCTIONING	6-1 - 6-3	6-1

		Paragraph	Page
	7. DIRECT AND GENERAL SUPPORT MAINTENANCE		
SECTION	I. Direct support maintenance	7-1 - 7-2	7-1
	II. General support maintenance	7-4 - 7-8	7-1
	III. General support troubleshooting	7-7, 7-8	7-2
	IV. General support repair	7-9 - 7-11	7-8
	V. General support testing	7-12 - 7-147-15	
CHAPTER	8. DEPOT OVERHAUL STANDARDS	8-1, 8-2	8-1
CHAPTER	9. ADMINISTRATIVE STORAGE	9-1, 9-2	9-1
APPENDIX	A. REFERENCES		A-1
	B. MAINTENANCE ALLOCATION		B-1
SECTION	I. Introduction		B-1
	II. Maintenance allocation chart		B-3
	III. Tool and test equipment requirements		B-4
	IV. Remarks		B-5
APPENDIX	c. COMPONENTS OF END ITEM LIST		
SECTION	I. Introduction		C-1
	II. Integral components of end item		C-2
	III. Basic issue items		C-6
APPENDIX	D. ADDITIONAL AUTHORIZATION LIST		
SECTION	I. Introduction		D-1
	II. Additional authorization list		D-2
APPENDIX	E. EXPENDABLE SUPPLIES AND MATERIALS LIST		
SECTION	I. Introduction		E-1
	II. Expendable supplies and materials list		E-2
	GLOSSARY		Glossary
	INDEX		Index 1

LIST OF ILLUSTRATIONS

<i>Number</i>	<i>Title</i>	<i>Page</i>
1-1	Front roadside corner view	1-5
1-2	View of AM-3349/GRC-106 installed, antenna connector, and RF shield	1-7
1-3	Rear roadside corner view of equipment	1-9
1-4	Dummy box as viewed through opening insecurity equipment mount	1-10
1-5	Front roadside view with Teletypewriter TT-98(*)/FG in the foreground	1-11
1-5.1	Cable assemblies used with interconnecting box J-4024/U	1-12
1-6	Front curbside view of storage box assembly, and chair secured by canvas strap	1-13
1-7	M577A1 with three antennas installed in their respective locations	
1-7.1	Mounting details for J-4024/U and DLED on Mounting Base MT-6442/G and Mount, Resilient MT-6444/VSC-3	1-15
1-8	Roadside view of dust covers installed on TT-78(*)/GGC, and TT-98(*)/FG	1-16
1-9	Rear roadside corner view of chad bin, and tape storage bin	1-17
1-10	Minor components used during different modes of operation	1-19
1-11	Storage items listed on storage box	1-20
2-1	Cabling diagram	2-3
2-1.1	Cabling diagram, AN/VSC-3A	2-3.1
2-1.2	Cabling diagram AN/VSC-3(with MK-2488/G) only,	2-4.1
2-1.3	Cabling diagram, AN/VSC-3A (with MK-2488/G)only	2-4.2
2-1.4	DLED KG-84/G and KG-84A/G internal strapping and control settings	2-6.3
2-2	Graph of antenna length versus frequency	2-7
2-3	Construction and assembly of doublet antenna	2-8
2-3	Preparing Mast AB-155/U for erection	2-9
2-5	Raising assembled Mast AB-155/U	2-10
2-6	Doublet antenna, erection completed	2-11
3-1	Front view of AN/VSC-3 control box	3-2
3-2	Radio Teletypewriter Set AN/VSC-3 remote control box, front panel controls and connector	3-3
3-3	Radio Teletypewriter Set AN/VSC-3 dummy box, front panel connectors	3-4
3-4	Radio Teletypewriter Set AN/VSC-3 remote operation, functional diagram	3-5
3-5	Remote binding posts on curbside of rear wall	3-10
3-6	Exterior binding posts with cover removed	3-11
6-1	Power distribution schematic diagram	6-2
6-1.1	Signal block diagram for AN/VSC-3 (with MK-2488/G and AN/VSC-3A (with MK-2488/G)	6-4
7-1	Control box schematic diagram	7-4
7-2	Dummy box schematic diagram	7-5
7-3	Rear view of control box with rear cover removed	7-9
7-4	Wiring diagrams for interconnecting cables W1 through W8	7-10
7-5	Wiring diagrams for interconnecting cables W9 through W17	7-11
7-6	Wiring diagrams for interconnecting cables W18 through W27	7-12
7-7	Voltage test procedure hookup	7-13
7-8	Continuity test procedure hookup	7-14
FO-1	Resistor, capacitor, and inductor color code chart	
FO-2	Teletypewriter dc signal circuits	
FO-3	Voice and cw signal circuits	

CHAPTER 1

INTRODUCTION

Section 1. GENERAL

1-1. Scope

a. This manual describes four radio teletypewriter communications configurations installed in Carrier Command Post M577A1. The basic configuration has model designation Radio Teletypewriter Set AN/VSC-3. The other models are the AN/VSC-3A, AN/VSC-3 (with MK-2488/G), and AN/VSC-3A (with MK-2488/G). MWO 11-5815-332-30 changes the AN/VSC-3 to AN/VSC-3A by replacing the Teletypewriter Set TT-98(*)/FG with the Terminal Communications Set AN/UGC-74A(V)3. Instructions in TM 11-5815-616-13 replace COMSEC equipment TSEC/KW-7 with a combination of interconnecting box J-4024/U and TSEC-KG-84 (or TSEC/KG-84A) through use of Installation Kit MK-2488/G. This replaces the TSEC/KW-7 mounting provisions with Mounting Base, Electronics Equipment MT-6442/G and Mount, Resilient MT-6444/VSC-3. This mounting arrangement fits in the same space formerly occupied by the TSEC/KW-7. The manual covers the operation of Operator, Organizational, Direct Support, General Support, and Depot maintenance of the equipment. It includes instructions for cleaning and inspection of the equipment and replacement of parts available to the repair person for categories of repair authorized by the Maintenance Allocation information in Appendix B of this manual. A list of items comprising an operable equipment is contained in paragraph 1-5, and a list of references is provided by Appendix A.

b. Throughout this manual, all references to the AN/VSC-3 apply to all models unless otherwise indicated.

c. Official nomenclature followed by (*) is used to indicate all models of an equipment item used in the M577A1 as listed below:

(1) Teletypewriter TT-98(*)/FG represents Teletypewriter TT-98/FG, TT-98A/FG, TT-98B/FG, TT-98C/FG, TT-98D/FG.

(2) Device, Low Level Signaling TT-523(*)/GGC represents Device, Low Level Signaling TT-523/GGC and TT-523A/GGC.

(3) Teletypewriter Reperforator-Transmitter TT-76(*)/GGC refers to Teletypewriter Reperforator-Transmitter TT-76A/CGGC, TT-76B/GGC, and TT-76C/GGC

(4) Radio Teletypewriter Modem MD-522(*)/GRC refers to Radio Teletypewriter Modems MD-522/GRC and MD-522A/GRC.

(5) Radio Set AN/GRC-106(*) refers to Radio Sets AN/GRC-106 and AN/GRC-106A.

(6) Receiver-Transmitter, Radio RT-622/GRC is a component of Radio Set AN/GRC-106, and Receiver-Transmitter, Radio RT-834/GRC is a component of Radio Set AN/GRC-106A.

(7) All references to the Teletypewriter Set TT-98(*)/FG other than operation and maintenance, also apply to the Terminal Communications AN/UGC-74A(V)3.

(8) All references to the Radio Teletypewriter Set AN/VSC-3 also apply to the Radio Terminal Set ANNSC-A.

d. Appendix C is current as of 10 November 1971.

NOTE

All references to RT-662/GRC also apply to RT-834/GRC. All references to MX-7778/-GRC also apply to MX-7778A/GRC.

1-2. Consolidated Index of Army Publications and Blank Forms.

Refer to the latest issue of DA Pam 25-30 to determine whether there are new editions, changes or additional publications pertaining to the equipment.

1-3. Maintenance Forms, Records, and Reports

a. Reports of Maintenance and Unsatisfactory Equipment. Department of the Army forms and procedures used for equipment maintenance will be those prescribed by DA Pam 738-750, as contained in Maintenance Management Update.

b. Reporting of Item and Packaging Discrepancies. Fill out and forward SF 364 (Report of Discrepancy (ROD)) as prescribed in AR 735-11-2/DLAR 4140.55/SECNAVINST 4355.18/AFR 400-54/MCO 4430.3J.

c. Transportation Discrepancy Report (TDR) (SF 361). Fill out and forward Transportation Discrepancy Report (TDR) (SF 361) as prescribed in AR 55-38/NAVSUPINST 4610.33C/AFR 75-18/MCO P4610.19D/DLAR 4500.15.

1-3.1 Reporting Equipment Improvement Recommendations (EIR)

If your equipment needs improvement, let us know. Send us an EIR. You, the user, are the only one who can tell us what you don't like about your equipment. Let us know why you don't like the design or performance. Put it on an SF 368 (Product Quality Deficiency Report). Mail it to: Commander, US Army

Communications-Electronics Command and Fort Monmouth, ATTN: AM SE L-PA-MA-D, Fort Monmouth, New Jersey 07703-5000. We'll send you a reply.

1-3.2 Administrative Storage

Administrative Storage of Equipment issued to and used by Army activities will have preventive maintenance performed in accordance with the PMCS charts before storing. When removing the equipment from administrative storage the PMCS should be performed to assure operational readiness. Disassembly and repacking of equipment for shipment of limited storage are covered in paragraphs 2-2 and 2-3.

1-3.3 Destruction of Army Electronics Materiel

Destruction of Army electronics materiel to prevent enemy use shall be in accordance with TM 750-244-2.

1-3.4 Hand Receipt **(-HR)** Manuals

This manual has a companion document with a TM number followed by “-HR” (which stands for Hand Receipt). The TM 11-5815-332-15-HR consists of preprinted hand receipts (DA Form 2062) that list end item related equipment (i.e., COEI, BII, and AAL) you must account for. As an aid to property accountability, additional -HR manuals may be requisitioned from the US Army Adjutant General Publications Center, Baltimore, MD, in accordance with the procedures in AR 25-30 and DA Pam 310-10.

Section II. DATA AND CHARACTERISTICS

1-4. Purpose and Use

a. Purpose. Radio Teletypewriter Set AN/VSC-3 installed in Carrier, Command Post M677A1 is a single-channel, single-sideband (ssb) radio teletypewriter terminal that provides half-duplex transmission and reception in the 2.0- to 29.999-megahertz (MHz) range. It provides communication in upper sideband (usb), compatible amplitude-modulation (am.), continuous-wave (cw), frequency-shift keyed (fsk), and narrow-band, frequency-shift keyed (risk) modes.

b. Use. The ANN SC-3 may be operated locally or from a remote site for voice, cw, or radio teletype communications (para 1-10). Teletype communications may be encrypted or in the clear mode. The AN/VSC-3 may be netted with other AN/VSC-3 sets, or other equipments such as Radio Teletypewriter Sets AN/VSC-2, AN/GRC-U2, AN/GRC-142, the AN/GRC-46-series, AN/VRC-29, and the AN/GRC-26-series.

1-5. Technical Characteristics

Complete Characteristics pertaining to the major components of the set are covered in the applicable technical manual (app A).

a. General Power Requirements.

28V DC source Vehicular power, or 28V power generator.
 Voltage 28 volts dc.
 Current 100 amperes maximum.

b. Radio Set ANGR-106(*).

Power consumption (maximum watts) 1204 (28V x 43A).
 Types of transmission and reception Cw, ssb voice (usb), voice am. (carrier plus usb), and radio teletypewriter (rtty) (fsk, ns, and nks diversity).
 Frequency range 2.0 to 29.999 MHz.
 RF power output cw and rtty (fsk, nsk, and nsk diversity) 200 watts (average).
 Upper-sideband voice and compatible AM voice (70 Watts carrier) 400 watts (peak envelope power).
 Type of operation One-way reversible (half-duplex).
 Normal groundwave Approximately 20 miles (32.18 km) with whip antenna. This distance varies with time of day, type of terrain, and frequency of operation.
 Types of antenna 15-foot whip or ANGRA-50 doublet.

c. Modem, Radio Teletypewriter MD-522(*)/GRC.

Power requirements 20 watts
 Shift frequencies:
 850 Hz (fsk) 2000 Hz ± 425
 85 Hz (nsk) 2805 Hz ± 42.5
 85 Hz (nak diversity) 425 ± 42.5 and 2805 Hz ± 42.5

d. Teletypewriter Reperforator-Transmitter TT-76(*)/GFC.

Keyboard Standard communications
 Type of characters English
 Method of recording Message printed and perforated on 1/8-inch paper tape.
 Characters per line Character counter records a maximum of 76 characters.
 Signalling code Five-unit, start-stop; stop impulse equals start impulse length multiplied by 1.42.
 Type of signals Neutral receiving, neutral sending.
 Speed:
 Operations per minute (opm) (send and receive) 368.1, 404, 460, or 600 opm.
 Words per minute (wpm) (send and receive) 60, 66, 76, or 100 wpm.
 Power required:
 Voltage 115 vac or 230 vac.
 Frequency 50 to 60 Hz (single phase)
 Consumption Approx 150 watts
 Line current requirements:
 DC line 20 or 60 ma neutral
 Tape capacity 5 hours, 20 minutes at 368.1 opm; 3 hours, 10 minutes at 600 opm.
 Radio frequency suppression Teletypewriter does not interfere with radio reception at frequencies between .85 and 150 MHz located 1 foot or more from radio antenna.

e. Teletypewriter TT-98(*)/FG.

Keyboard and typebar symbols:
 Type of characters English
 Characters per line 72
 Type of paper feed Friction or sprocket
 Signalling:
 Transmission 7.42, start-stop, 5-unit code
 Reception 7.00, 7.42, and 8.00 start-stop, 5-unit code impulses within acceptable range limits when appropriate gearset is installed to match baud rate in use on signal line.
 Type of signal Neutral (20 or 60 ma).
 Operational speeds:
 45.5-baud rate (368.1 opm gearset installed) 61.5 wpm with 7.42 units code; 56.9 wpm with 8.00-unit code.

56.8-baud rate (460-opm gearset installed)	75 wpm with 7.42 units code:
75-baud rate (600-opm gearset installed)	70 wpm with 8.00 unit code
	100 wpm with 7.42-unit code:
	93.6 wpm with 8.00 unit code
Code impulse lengths:	
45.5-baud rate	22 millisecond
56.8-baud rate	17.6 milliseconds
75-baud rate	13.5 milliseconds
Power requirements	Approx. 180 watts: 95-125 v, 190-250 v. 50-60 Hz ac
Paper capacity	Adjustable to accommodate standard 1-through 6-copy roll, fanfold paper, or sprocket-fed forms, 8¼ in. wide.

Keyboard	MIL-STD-1280 Type 1, Class 1 plus 4 special keys.
Printer:	
Type	Drum
Print Rate	60 characters per second, minimum.
Printed Characters	Gothic; 63 characters of the ASCII subset and a diamond.
Printed Characters per line ..	Operator selectable form 40 to 80 characters.
Paper Type and Capacity	Single or multi-ply (3 ply maximum) roll paper, 5 inches in diameter by 8½ inches wide. Single or multi-ply (3 ply maximum) fanfold.
Other Printer Features	Single or double line feed. Paper low lamp, for roll paper only. Automatic shutdown of printing on physical paper outage (for roll paper only). Automatic shutdown of print drum motor if there is no printing for between 2 and 4 minutes.
Power Requirement	100 Watts, maximum.
Operating Voltages	26 ± 4 Volts dc 115 Volts ac ± 15%, 50, 60 or 400 Hz ± 5%. 230 Volts ac ± 15%, 50, 60 or 400 Hz ± 5%.
Voltage and Transient Voltage Protection	Overvoltage 36 Volts dc input for 1-hour maximum. Over voltage transients, 100 Volts dc input. Under voltage transients, 15 Volts dc input.
Environmental Conditions:	
Operating Temperature	-25F to +125F (-32C to +52C) plus solar radiation.
Nonoperating Temperature ..	-65F to +155F (-54C to +68C)
Case Closed	Water and dust proof.
Case Cover Removed	Spray proof.
Physical Characteristics:	
Total Weight	100 pounds with case, cover and paper.
Dimensions	21.75 inches long, 17.5 inches wide and 9.5 inches high.

1-6. Technical Characteristics, Terminal Communications AN/UGC-74A(V)3

The technical characteristics of the AN/UGC-74A(V)3 are as follows:

Application	Used to compose, edit, transmit, receive, print and store messages.
Operational States	Operate as an intelligent communications terminal, a keyboard send/receive terminal, or a receive only terminal.
Type of Installation	Tactical; fixed or mobile, table, or relay rack mounted.
Operating Speeds:	
	<i>Baud Rate</i>
	1200 ASCII 10 unit (1 stop bit) ASCII 11 unit (2 stop bits)
	600 ASCII 10 unit (1 stop bit) ASCII 11 unit (2 stop bits)
	300 ASCII 10 unit (1 stop bit) ASCII 11 unit (2 stop bits)
	150 ASCII 10 unit (1 stop bit) ASCII 11 unit (2 stop bits)
	75 ASCII 10 unit (1 stop bit) ASCII 11 unit (2 stop bits) Baudot 7 unit (1 stop bit) Baudot 8 unit (2 stop bits)
	50 Baudot 7 unit (1 stop bit) Baudot 8 unit (2 stop bits)
	45.5 Baudot 7 unit (1 stop bit) Baudot 8 unit (2 stop bits)
System Interface	Operates with MIL-STD-188-114 equipment (e.g. KW-7, TH-22/TG MD-522) and the following COMSEC equipments:

1.6.1 Technical Characteristics, inter-connecting Box J-4024/U (used in AN/VSC-3 (with MK-2488/G) and AN/VSC-3A (with MK-2488/G) only).

The technical characteristics of the J-4024/U are as follows:

Application Used to interface loop current signals from tele-typewriters and mo-dems, and to convert the signals +/- polar 6 volt levels.

Type of Installation Installed on Mounting Base MT-6442/G with Mount, Resilient MT-6444/VSC-3. Both mounts are provided in the MK-2488/G installation Kit.

Power Consumption 120 watts (maximum).

Operating Voltage 28 volts dc, 115 volts ac (+/-10%) 230 volts ac (+/-10%)

Section III. DESCRIPTION

1-7. Description of System

a. General. Installation of the AN/VSC-3 in the M577A1 vehicle is given in TM 11-2300-359-35-3. The AN/VSC-3 components (para 1-6) are mounted on a shelf and table located at the time roadside, on the roadside wall, on the front wall and curbside table of the vehicle. Location of equipments and mountings are discussed in *b* through *g* below. Refer to manuals covering standard equipments (app A) for detailed descriptions. Descriptions of components not covered in their own manuals are included in paragraph 1-8.

NOTE

Illustrations used to show the configuration include Local Control C-434/-GRC and Intercommunications Set AN/VIC-1(V) components. These items are not part of the AN/VSC-3, but may be used with the set.

b. Roadside Shelf. The following items are mounted (as indicated) on the shelf, starting from the front of the vehicle.

(1) Transient Suppressor, Electrical MX-7778/GRC (fig. 1-1), bolted directly to the shelf.

(2) Amplifier, Radio Frequency AM-3349/GRC-106, mounted on Mounting MT-3140/GRC-106 and two resilient mounts (fig. 1-2) that are bolted to the shelf.

(3) Clock (fig. 1-1), bolted to the front edge of the shelf.

(4) Motor Generator PU-724/G (inverter), bolted directly to the shelf.

(5) RCV-SEND switch (fig. 1-3), bolted directly to the edge of the shelf.

(6) Local Control C-434/GRC brackets, bolted to the bottom of the shelf. Also a tab to hold the C-434/GRC (part of Control Group AN/GRA-6) in the brackets, bolted to the front edge of the shelf.

c. Roadside Wall. The following items are mounted on the roadside wall:

(1) Control box (fig. 1-3) bolted to two existing vehicle brackets with standoff brackets.

(2) Dummy box (fig. 1-4), bolted to a vehicle tapped mounting on the wall behind the secure equipment mounting base (fig. 1-3) and screwed to the table.

d. Roadside Table. The following items are mounted (as indicated) on the table starting from the front of the vehicle.

(1) Receiver-Transmitter RT-662/GRC and Modem, Radio Teletypewriter MD-522(*)/GRC (fig. 1-1), stack mounted on Mounting MT-3140/GRC-106 and two resilient mounts that are bolted to the table.

(2) In the AN/VSC-3 (with MK-2488/G) Teletypewriter TT-98(*)/FG (figs 1-1 and 1-5) is installed on a special shock-mounted table (para 1-8g).

(3) in the AN/VSC-3A and AN/VSC-3A (with MK-2488/G, Terminal, Communications AN/UGC-74A (V)3 is installed in the same location (figs 1-1 and 1-5) as was the TT-98(*)/FG. The AN/UGC-74A(V)3 is mounted on shock mounts that are bolted to the table. An auxiliary battery case is located to the rear of the AN/UGC-74(V)3.

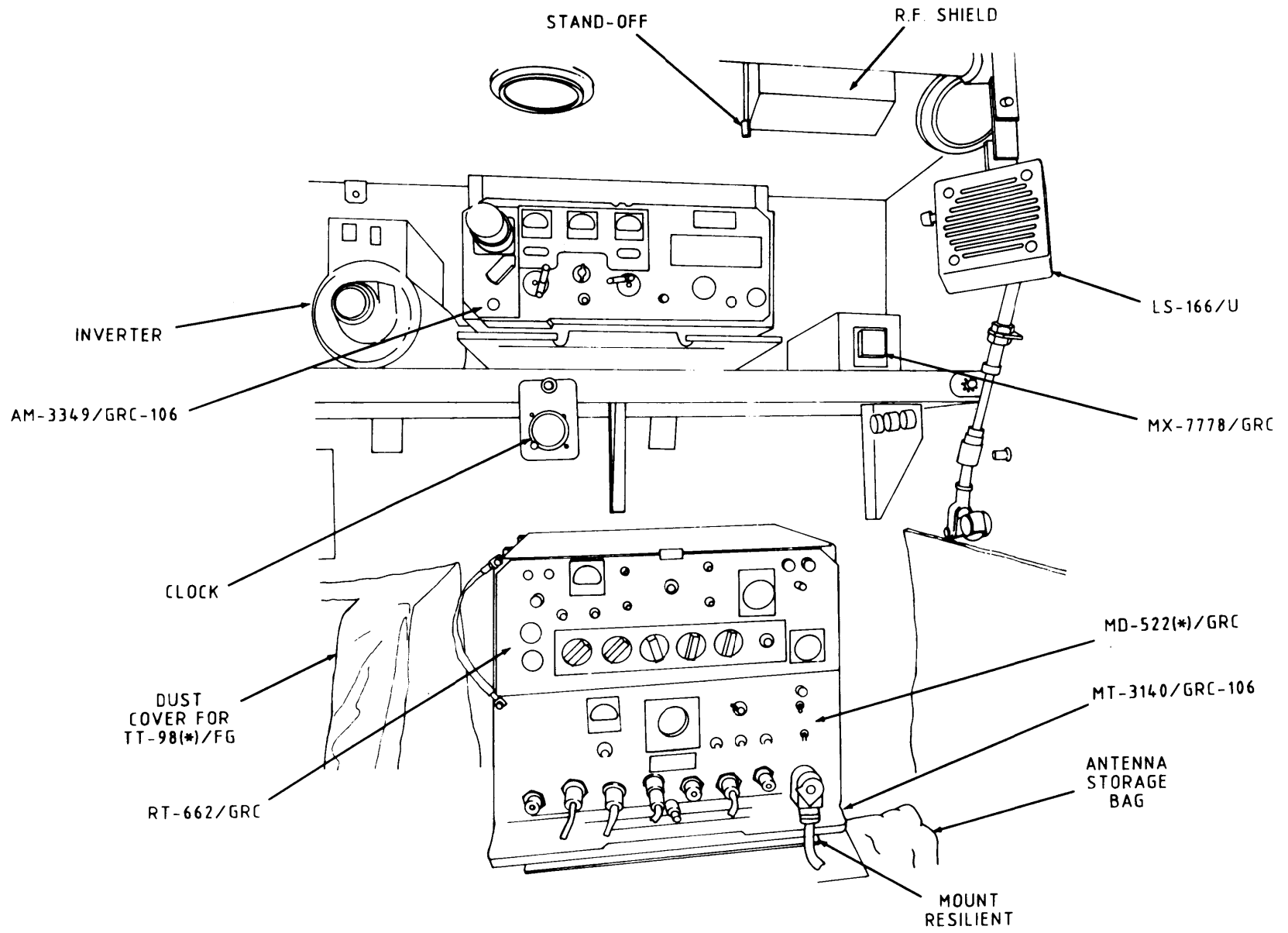

Figure 1-1. Front roadside corner view.

EL 5815-332-15-TM-1

(4) In the AN/VSC-3 and AN/VSC-3A, COMSEC equipment TSEC/KW-7 is installed on the secure equipment base (fig 1-3) which is bolted directly to the table. In the AN/VSC-3 (with MK-2488/G), the TSEC/KW-7 security equipment base is removed and Mounting Base MT-6442/G and Mount, Resilient MT-6444/VSC-3 (fig. 1-7.1) are installed. The same installation is applicable to the AN/VSC-3A (with MK-2488/G). This new mounting arrangement accommodates the Interconnecting Box J-4024/U and its companion COMSEC equipment TSEC/KG-84 or TSEC/KG-84A.

(5) Teletypewriter, Reperforator-Transmitter TT-76(*)/GGC, mounted on a special table (para 1-8f) that is on spacers and shock mounts.

(6) Tape-storage bin (fig. 1-9), bolted under the table with table support bolts.

e. Curbside. The following items are mounted on the curbside of the vehicle.

(1) Storage box (fig. 1-6), bolted directly to the shelf in the front corner.

(2) Chair storage, two footmans loops, and a canvas strap on the table.

f. Antenna. The AN/GRC-106(*) whip antenna base (AB-652/GR) is mounted at the vehicles front roadside antenna position (fig. 1 -7). The AB-652/GR antenna connector extends into the vehicle (fig. 1-2). A shield is attached to the connector to prevent personnel from coming in contact with antenna connector.

NOTE

Figure 1-7 shows two antennas installed on the roof of M577A1 which are not a part of the AN/VSC-3. They are installed for use if an additional receiver-transmitter or receiver is to be used.

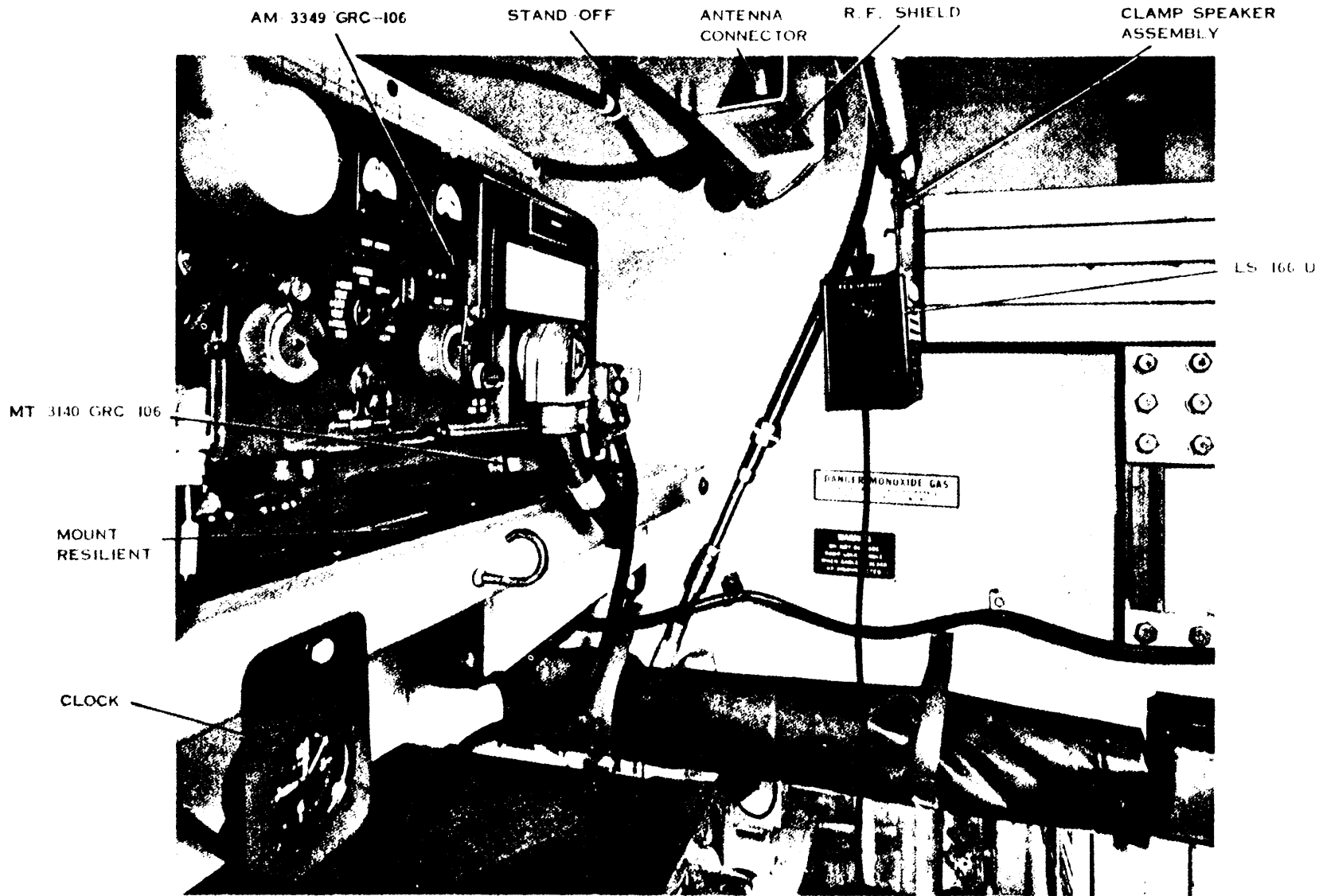

EL 5815 332-15 TM 2

Figure 1-2. View of AM-3349 / GRC-106 installed, antenna connector, and RF shield.

g. *AN/GRC-106(*) Speaker.* An LS-166/U speaker is clamped to the handrail at the roadside front of the vehicle.

1-8. Description of Component.

a. *Storage Box* (fig. 1-6). The storage box is used to store miscellaneous items such as pliers, remote box, screwdriver, etc. The box has two compartments and is made of sheet metal and has a cover secured by spring fasteners. A storage list (fig. 1-11) and a cabling diagram (fig. 1-6) are shown on two of the storage boxes sides.

b. *Dummy Box* (fig. 1-4). The dummy box completes the teletypewriter dc loop during non-

secure operation. During secure operation, the dummy box is not used. The box is made of sheet metal and has connectors on its front panel.

c. *Control Box* (fig. 1-3). The control box controls the application of all dc and ac power to the major components of the AN/VSC-3. The positive side of 28 volts dc from the M577A1 electrical system is applied through a connector on the right-hand side panel. Minus 28 vdc is connected as a ground strap to a stud on the left-hand side panel. Controls and indicators are contained on the front panel.

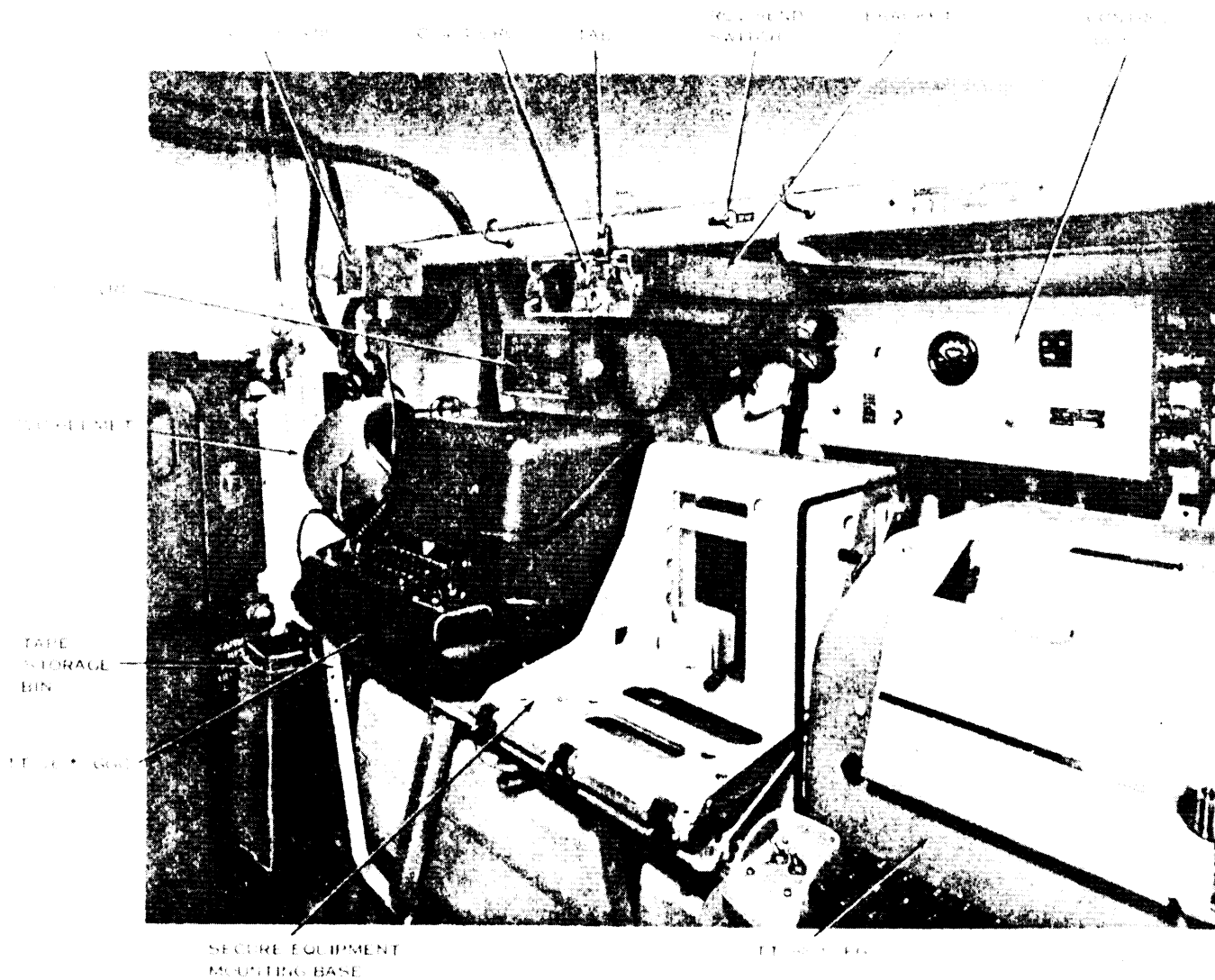
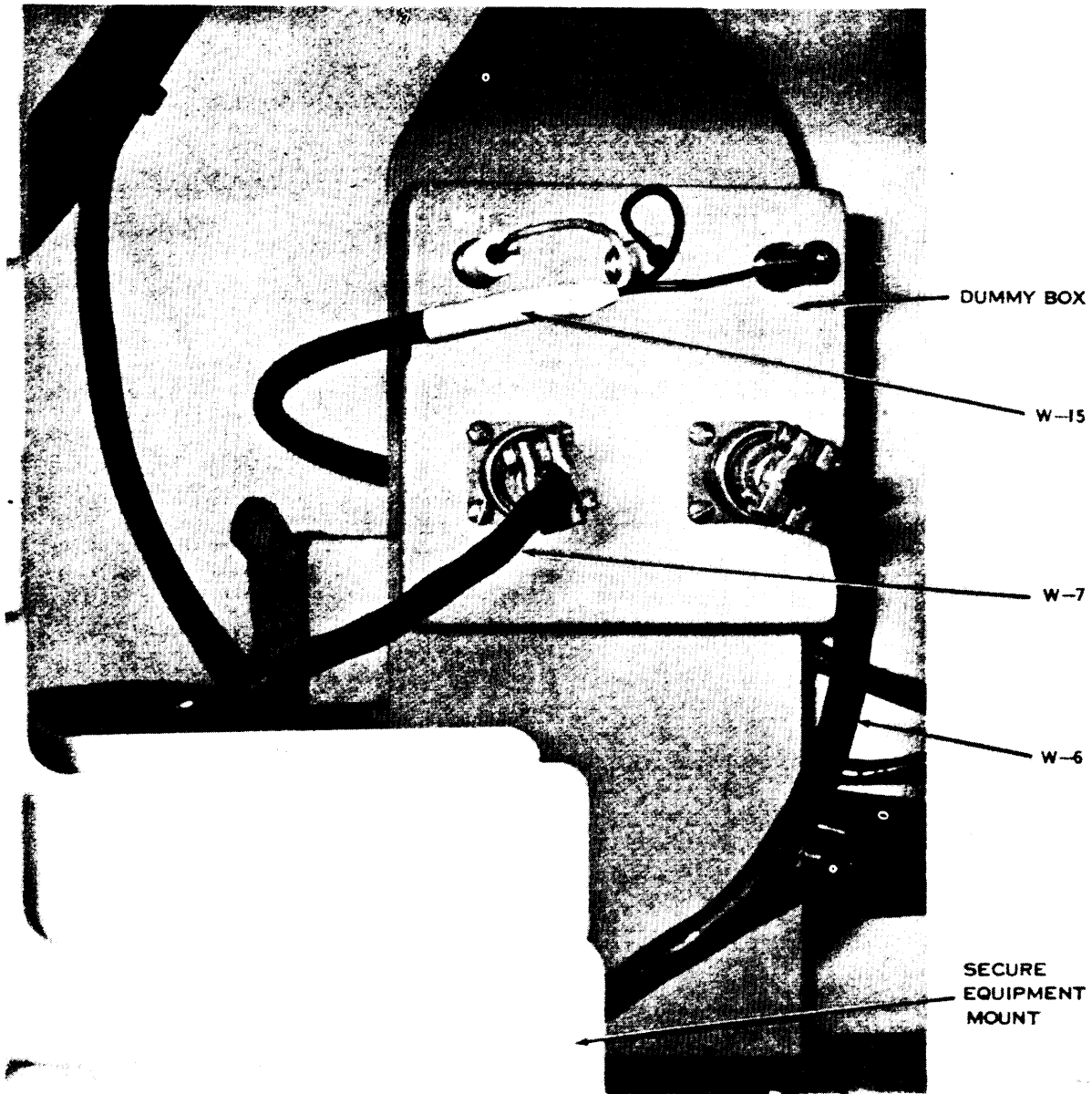

Figure 1-3. Rear roadside corner view of equipment.



EL 5815-332-15-TM-4

Figure 1-4. Dummy box as viewed through opening in security equipment mount.

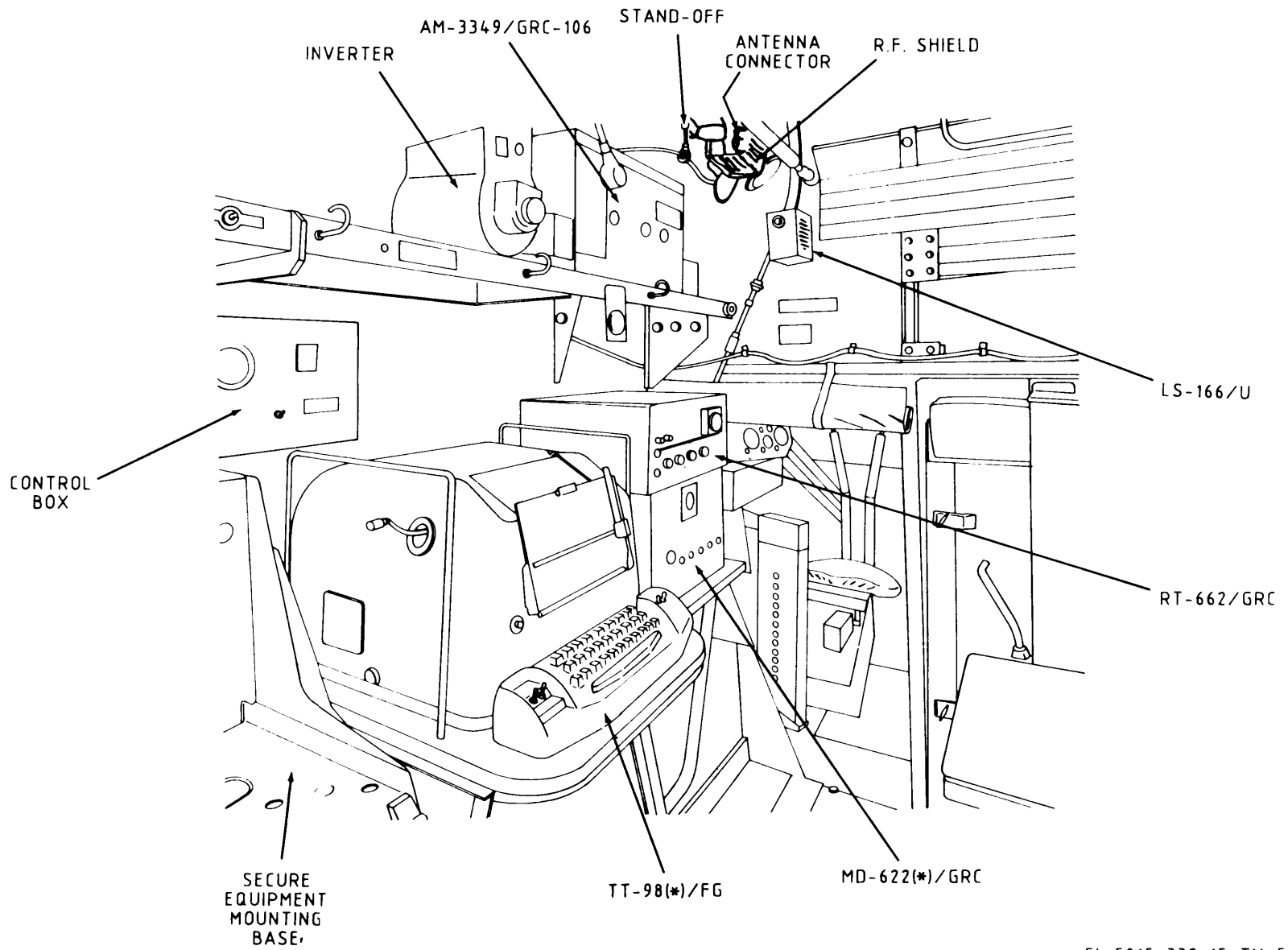

Figure 1 5. Front roadside view with Teletypewriter TT 98(*)/FG in the foreground.

EL 5815-332-15-TM-5

d. *Dust Covers* (fig. 1-8). Dust covers are provided for the TT-76(*)/GGC, TT-98(*)/FG, and security equipment. The covers are made of fabric and the two teletypewriter covers have plastic windows. The cover for the TT-98(*)/FG has an opening on the left side to allow access to the platen crank. The teletypewriter covers are secured in place by an elastic cord sewed along its bottom edge. *They are to be used when the vehicle is moved and under conditions of sand and dust. See paragraph 3-15 for instructions.*

e. *Storage Bin and Tape Guide Assembly.* The assembly (fig. 1-9) consists of a metal framework and attached canvas bag that is fastened to the edge of the roadside table to catch the tape from the TT-76(*)/GGC. A plate is placed in the bottom of the bag to keep it in the extended position.

f. *TT-76(*)/GGC Table Assembly.* The table mounts the TT-76(*)/GGC and has a support attached to the left-hand side to support a dust cover (d above). A chad bin is also attached to the left-hand side of the table. The chad bin is a metal tray that is attached beneath the table to catch the TT-76(*)/GGC chad. The bin slides under the table like a drawer and is secured with a captive thumb screw.

g. *TT-98(*)/FG Table Assembly.* The table (fig. 1-5) mounts to the TT-98(*)/FG and has a support attached to each side to support a dust cover.

h. *Remote Control Box* (fig. 1-10). The remote control box is used in conjunction with Control

Group AN/GRA-6 to accomplish voice or teletypewriter (tty) transmission from a remote site up to 1 mile from the AN/VSC-3. All controls and connectors are mounted on the front panel. A pendant plug provides connection to the C-433/GRC (part of AN/GRA-6).

i. *Resistor Assembly.* This is a 5600-ohm resistor with a lug attached to each end. The assembly is used in the TT-76(*)/GGC, in conjunction with TT-523(*)/GGC.

j. *Jumper Wire.* This is a 4 1/2-inch length of wire with a lug at each end. The jumper is used under the TT-76(*)/GGC (fig. 7-1)

k. *Binding Post Assembly.* The binding post assembly is painted red and black. It contains two binding posts with a 27,000-ohm resistor connected between the binding posts. A lugged lead is also connected to one binding post. The assembly is used to reduce the loop current during remote secure teletype operations, using the TT-4C/TG (para 3-14b(3)).

l. *Jumper Cables.* Two 6 1/2-inch wires (fig. 1-10) with banana plugs on the ends are provided. The cables are for use with the security equipment.

m. *Low Level Signaling Device, TT-523(*)/GGC.* This device is inserted into the connector block behind the transmitter distributor (Tape reader) assembly on the TT-76(*)/GGC when operating in the secure radio teletypewriter mode.

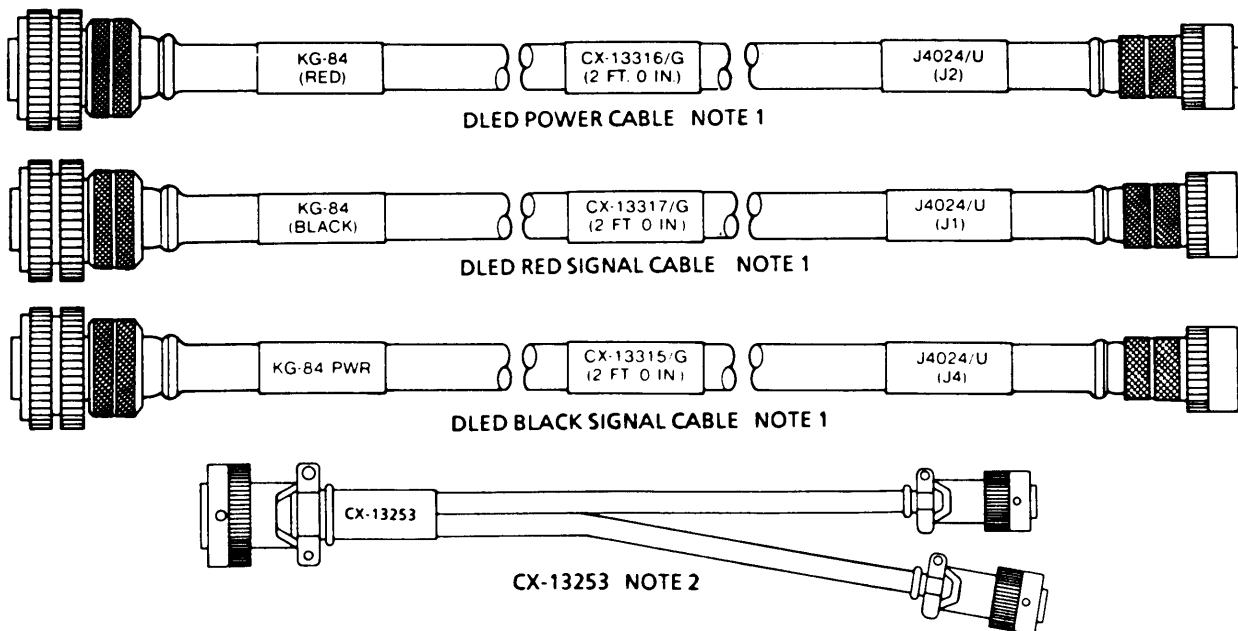

NOTE 1 USED WITH AN/VSC-3 (WITH MK-2488/G) AND AN/VSC-3A (WITH MK-2488) ONLY
 NOTE 2 USED WITH AN/VSC-3A (WITH MK-2488/G) ONLY

Figure 1-5.1. Cable Assemblies used with Interconnecting Box J-1024/U.

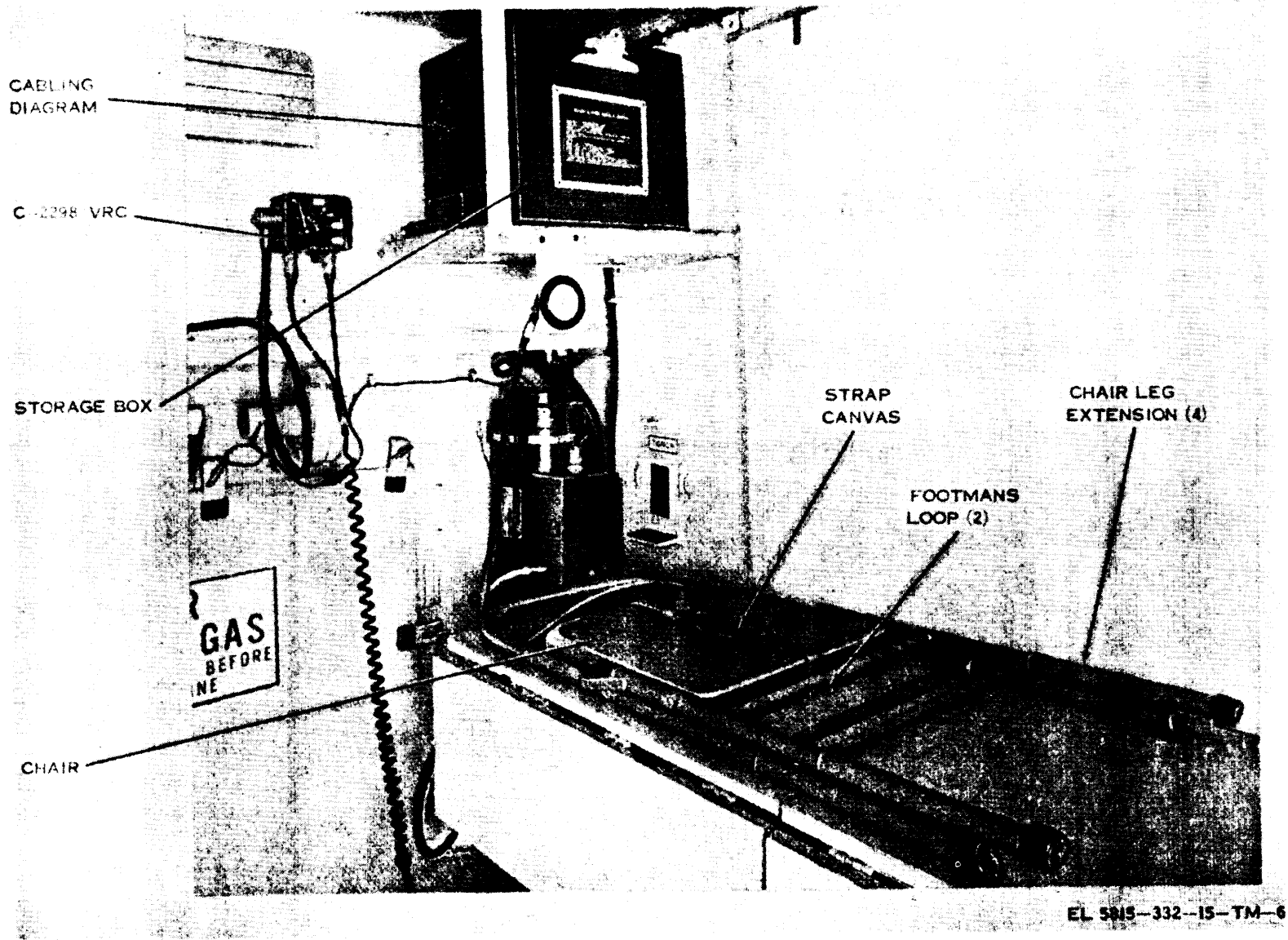
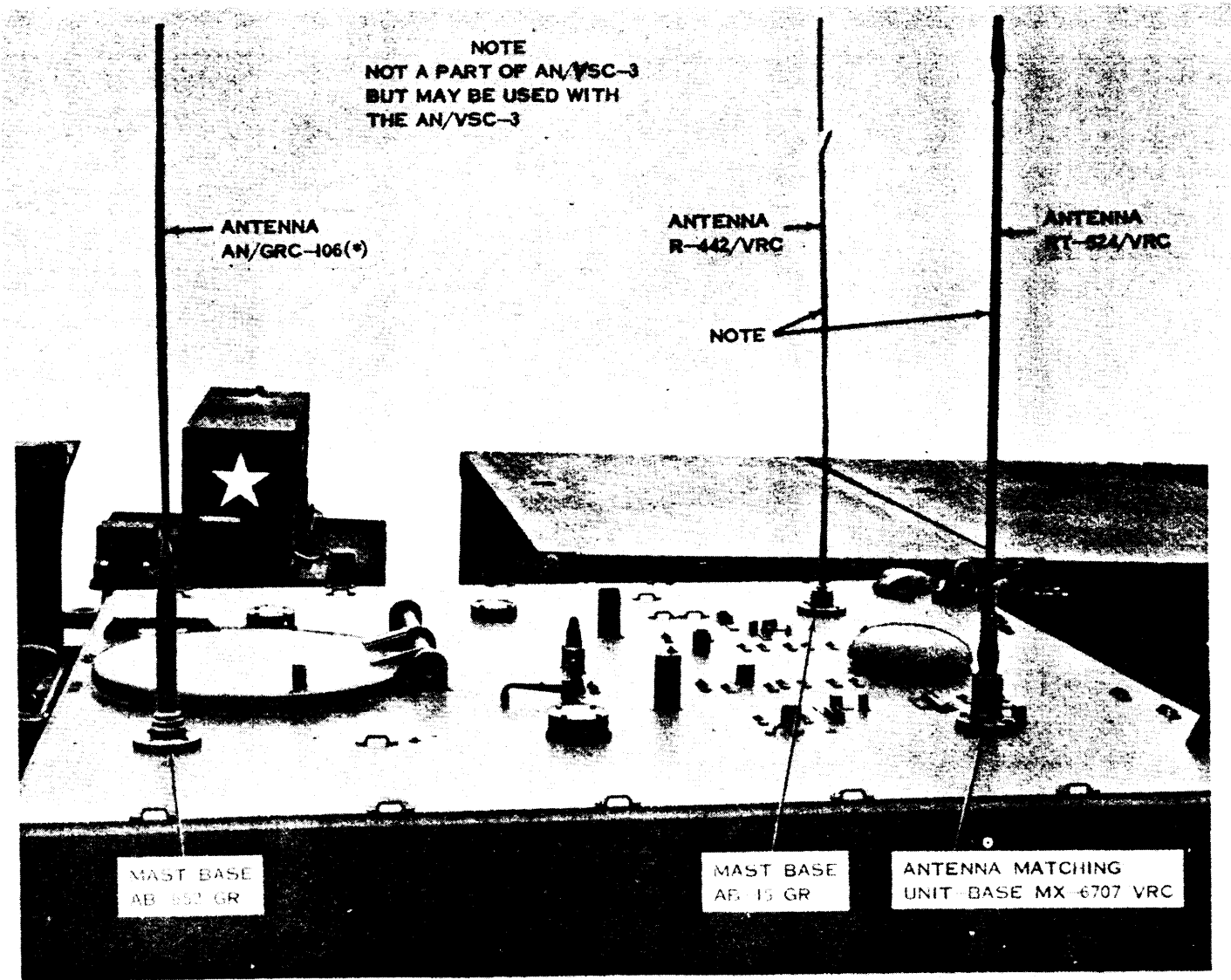

Figure 1-6. Front curbside view of storage box assembly, and chair secured by canvas strap.



EL 5815-332-15-TM-7

Figure 1-7. M577A1 with three antennas installed in their respective locations.

1-9. Additional Equipment

a. Remote Control AN/GRA-6 and sufficient field wire (three pairs for voice, cw, and teletypewriter operation) to reach the remote site are required for remote operation. A TT-4C/TG or equivalent and

power source for same is required for remote operation.

b. Security equipment is required for secure local or remote RTTY operation. A red-black binding post assembly (para 1-8k) (for modification of a TT-4C/TG for secure remote operation) is provided in the installation unit.

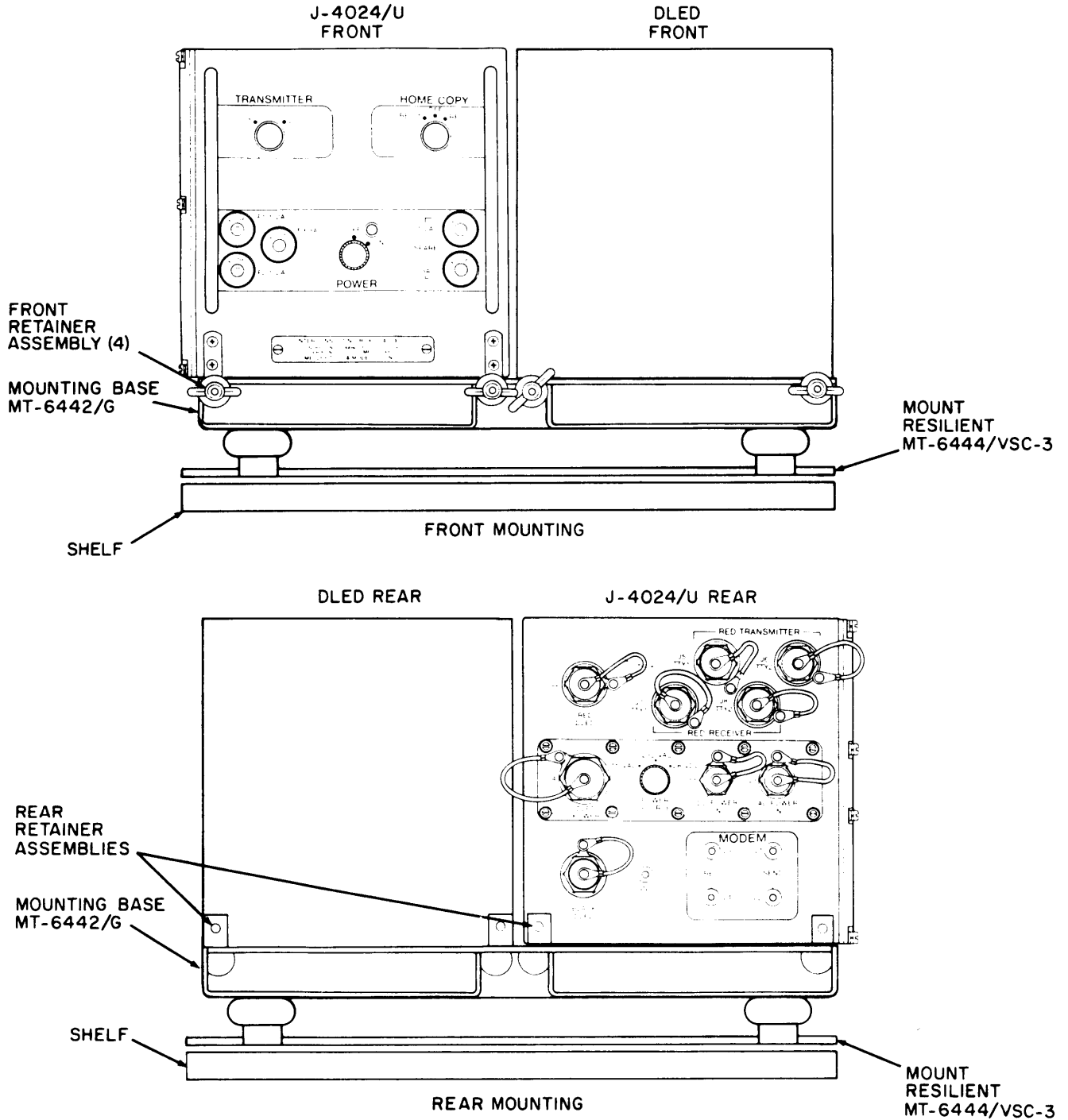
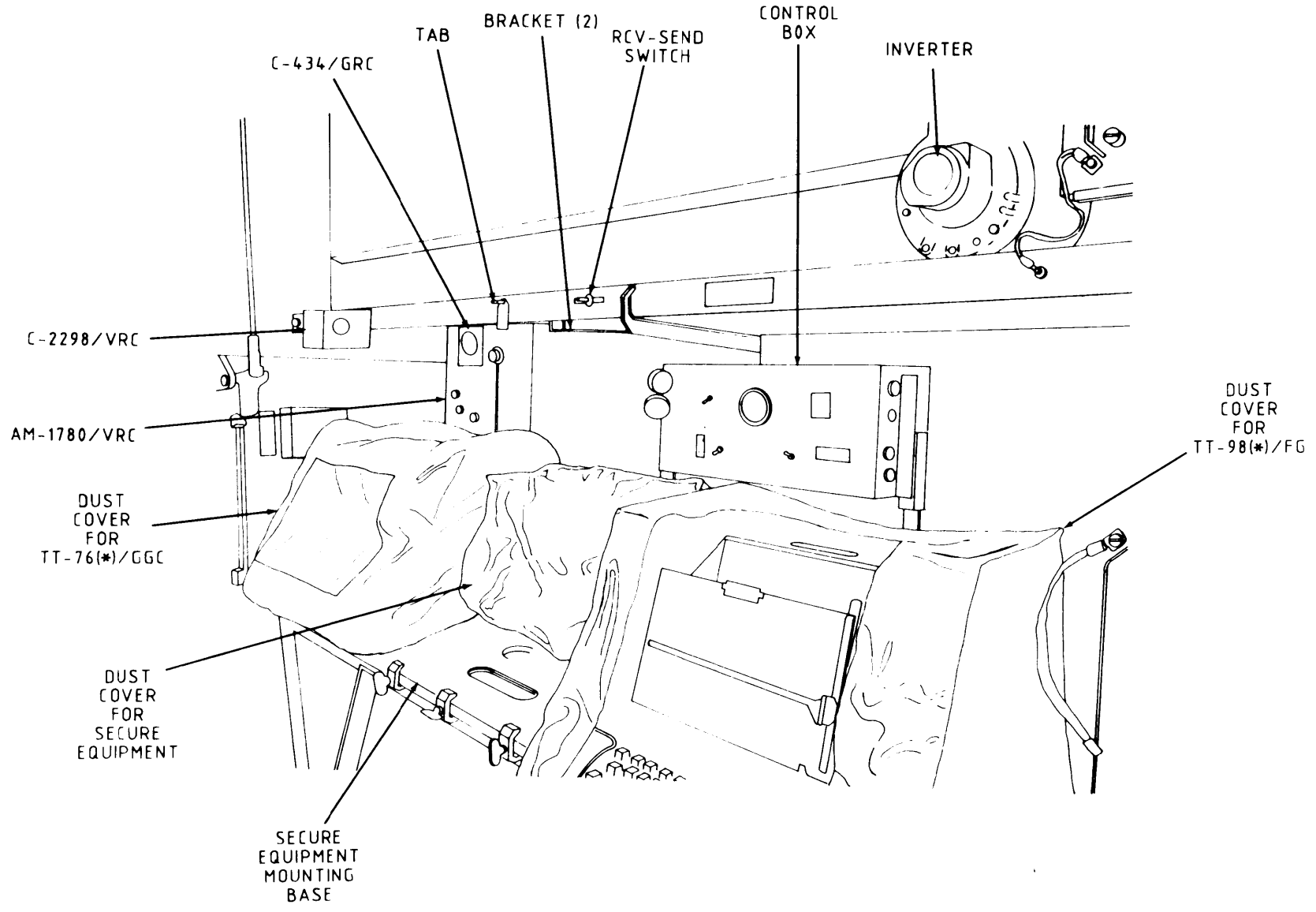
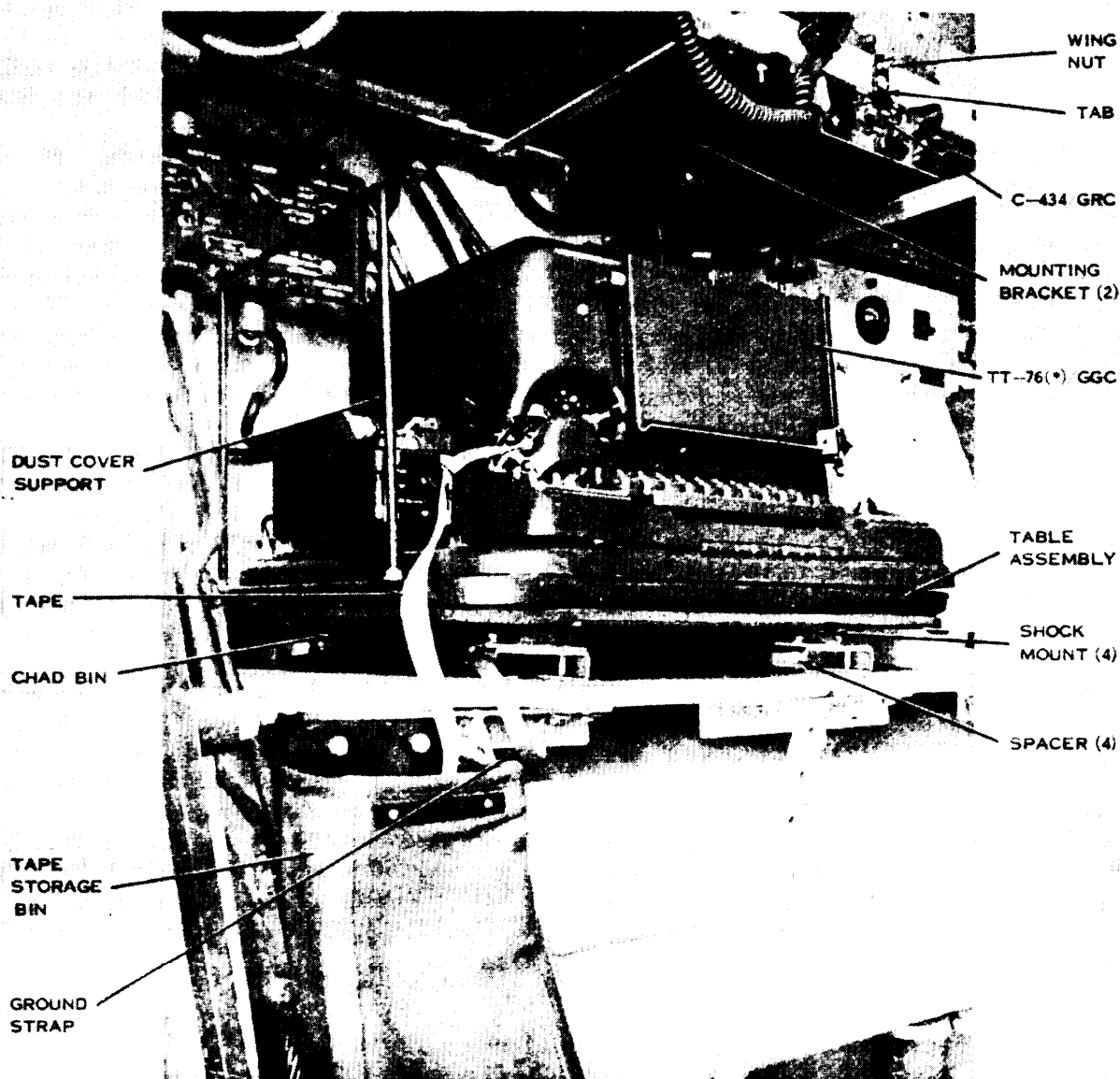

Figure 1-7.1. Mounting Details for J-4024/U and DLED on Mounting Base MT-6442/G and Mount, Resilient MT-6444/VSC-3.



EL 5815-332-15-TM-8

Figure 1 8. Roadside view of dust covers installed in TT-76(*)/GGC and TT-98(*)/FG.



EL 5815-332-15-TM-1

Figure 1-9. Rear roadside corner view of chad bin, and tape storage bin.

1-10. System Application

NOTE

VOX Operation of the AN/VSC-3 is not possible.

a. Local Operation. The AN/VSC-3 is capable of one-way reversible operation in the ssb voice, compatible am voice, cw, fsk, nsk, or diversity nsk RTTY mode. operation is accomplished by alternate transmission or reception through the basic AN/GRC-106(*) and MD-522(*)/GRC. Modes of operation are given below.

(1) *Voice.* The AN/GRC-106(*) may be operated from the AN/VSC-3 control box with a H-33/PT Headset or a M-29/U Microphone. Intercommunications Set AN/VIC-1(V) may be connected to the control box in place of the H-33/PT or M-29/U. With this connection, the AN/GRC-106(*) may be operated from any of three crew positions in the vehicle.

(2) *Cw.* The AN/GRC-106(*) may be operated in the cw mode from the control box with a telegraph key (KY-116/U or equal), and headset H-227/U or loudspeaker LS-166A/U.

(3) *Radio teletypewriter.* Teletypewriter Reperforator-Transmitter TT-76(*)/GGC and Teletypewriter Set TT-98(*)/FG are operated in the clear and secure modes through Modem Radio Teletypewriter MD-522(*)/GRC and the AN/GRC-106(*).

(a) The TT-76(*)/GGC provides transmission facilities either from manual operation of its keyboard, or from punched tape copy processed through its transmitter-distributor. Messages received by the equipment are printed and punched on paper tape which may be used for later trans-

mission. Tapes may be prepared locally without disturbing the connected signal circuits. The TT-523(*)/GGC (para 1-8m) and 5,600-ohm resistor (para 1-8i) are installed when operating with security equipment.

(b) The TT-98(*)/FG provides facilities for transmitting, monitoring, or receiving messages in page copy.

b. Remote Operation. All modes of local operation are possible from a remote cite ((1), (2), and (3) below). When operation is from a remote cite, Local Control C-434/GRC (part of AN-/GRA-6) is connected to the control box in place of an M-29/U, H-33/PT, or the AN/VIC-1(V) (a(1) above). Field wire is connected from the C-434/GRC to C-433/GRC at the remote site (fig. 3-4). The C-433/GRC is connected to the remote control box.

(1) *Voice.* Operation of the AN/GRC-106(*) is with Handset H-33/PT that is connected to the remote control box (fig. 3-4).

(2) *Cw.* The AN/GRC-106(*) is operated in the cw mode with a telegraph key that is connected to the control box with field wire and cable W22. Headset H-227/U is connected to the remote control box.

(3) *Radio teletypewriter.* The remote control box is connected to the control box in the AN/VSC-3 with field wire and cable W-22. A teletypewriter is connected to the remote control box. Signals from the teletypewriter are routed through the control box to the MD-522(*)/GRC for operation of the AN/GRC-106(*). The RTTY SEND / RECEIVE function is controlled by the SEND / RECEIVE switch on the remote control box.

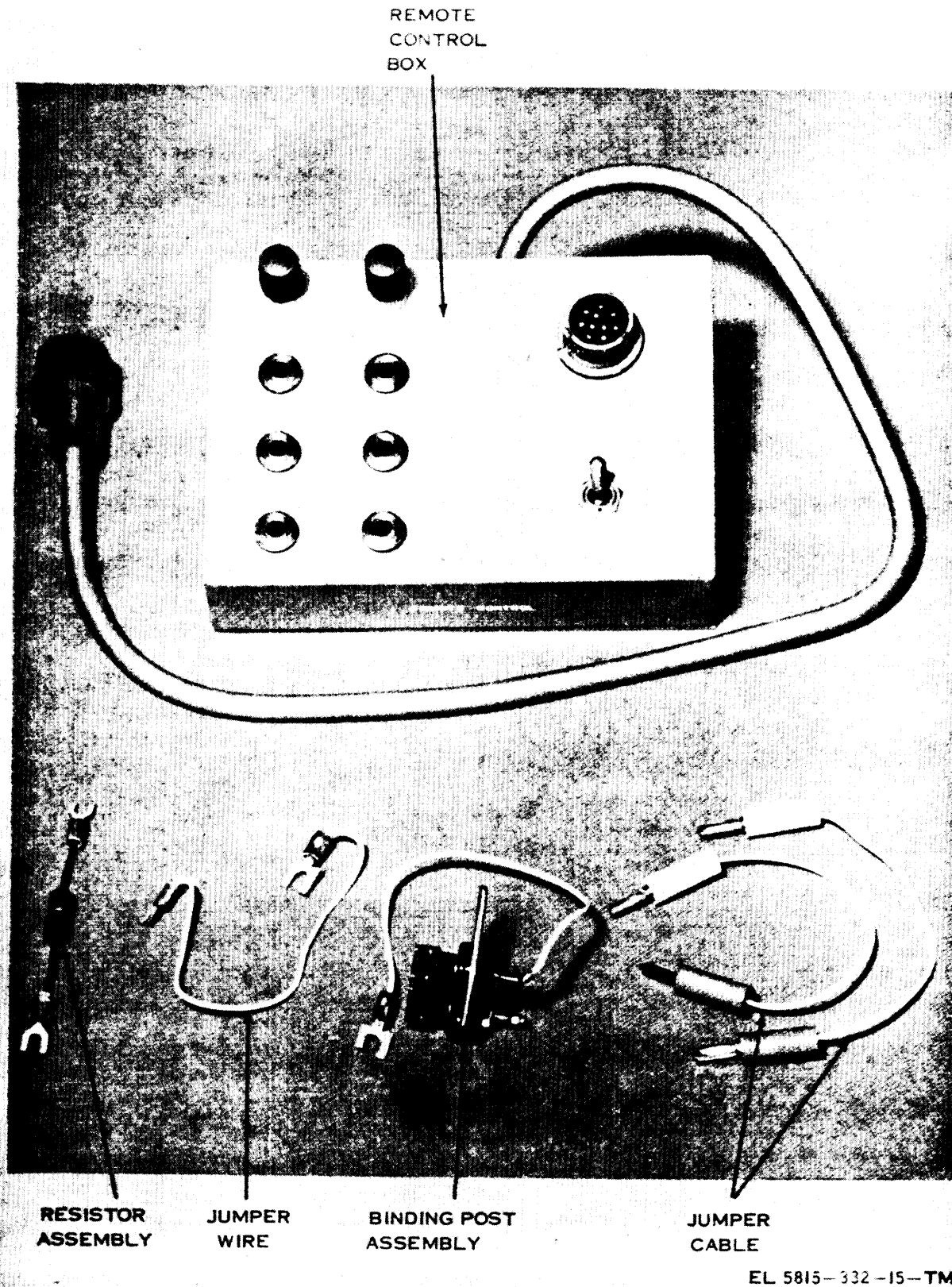

Figure 1-10. Minor components used during different modes of operation.

STORAGE AREA

- TELETYPEWRITER RIBBON SPARE (2)
- TELETYPEWRITER PAPER ROLL (SPARE)
- TELETYPEWRITER TAPE (SPARE)
- MICROPHONE M-29/U
- HEADSET H-227/U
- TELEGRAPH KEY KY-116A/U W/CABLE CX-1852/U
- FOUR CELL LANTERN AND SPARE BATTERIES
- SCREW DRIVER
- PLIERS
- ALLEN WRENCHES
- WRENCH, OPEN END 1/2 X 9/16 (2 EA.)
- CARTRIDGE FUSE 1/8 AMP (5 EA.) (SPARES)
- CARTRIDGE FUSE 1.6 AMP (5 EA.) (SPARES)
- CARTRIDGE FUSE 2 AMP (10 EA.) (SPARES)
- SPARE LAMPS FOR TT-76C/GGC AND TT-98/FG
- JUMPER WIRE W/BANANA PLUGS (2 EA.)
- REMOTE BOX
- "RED/BLK" BINDING POSTS (REMOTE)
- CX-1200/U CX-1201/U
- TM: ANGRC-106
- TM: MD-522/GRC
- TM: TT-98/FG
- TM: TT-76C/GGC
- TM: ANVSC - 3 SYSTEMS

EL 5815 332 15 TM 11

Figure 1-11. Storage items listed on storage box.

CHAPTER 2 INSTALLATION

Section 1. SERVICE UPON RECEIPT OR EQUIPMENT

WARNING

During installation of this equipment, comply with all safety requirements in TB SIG 291. Serious injury or DEATH could result from failure to comply with safe procedures and practices.

2-1. Checking Received Equipment

NOTE

When AN/VSC-3 equipment is received, it is to be installed in accordance with installation instructions in TM 11-2300-359-15-3.

a. Check that the equipment is complete as listed on the packing slip or as listed in paragraph 1-6.

b. Inspect the equipment for damage. If the equipment has been damaged during shipment, refer to paragraph 1-3, for the correct form.

c. Check that the proper fuses are installed in the teletypewriters and radio sets as outlined in the appropriate technical manual (app A).

d. Check that all equipments are firmly mounted.

e. Check that all ground straps are securely connected.

2-2. Cable Connections

a. Refer to the cabling chart (b below) and the appropriate cabling diagram. (Fig. 2-1) for the AN/VSC-3, Fig. 2-1.1 for the AN/VSC-3A, Fig 2-1.2 for the AN/VSC-3 (with MK-2488/G), Fig. 2-1.3 for the AN/VSC-3A (with MK-2488/G). Make sure that all cables are correctly connected.

NOTE

The cabling diagram is also provided on one side of the storage box (fig. 1-6) in some models

b. Cabling Chart.

Cable No.	From	Connection	To	Connection
W1	RT-662/GRC	AUDIO 1	MD-522(*)/GRC	RCVR TRANS AUDIO
W2	MD-522(*)/GRC	MICROPHONE	Control box	MD-522(*)/MIC
W3	MD-522(*)/GRC	DC LOOP NO. 1	Control box	DC LOOP 1
W4	MD-522(*)/GRC	PRIMARY POWER	"Y" Cable	60-42122-2S
W5	Control box	DUMMY PWR	TTY Sec Device	27 VDC IN
W6	Control box	LOOP OUT	Dummy box	LOOP OUT
W7	Control box	LOOP IN	Dummy box	LOOP IN
W8	RT-662/GRC	REC IN	AM-3349/GRC-106	RCVR ANT
W9	RT-662/GRC	PA CONTROL	AM-3349/GRC-106	CONTROL
W10	AM-3349/GRC-106	PWR	MX-7778/GRC	OUTPUT 1
W11	RT-662/GRC	RF DRIVE	AM-3349/GRC-106	RF DRIVE
W12	RT-662/GRC	PWR	"Y" Cable	60-42122-2S
W13	Control box	TRANS SUPPRESSOR	MX-7778/GRC	Power in
W14	Control box	INVERTER	Inverter	28 VDC Power input
W15 ^d	Control box	DUMMY	Dummy box	WHT BLU BLK
W16 ^e	Control box	SEND TT-76	TT-76(*)/GGC	TB-1
W17 ^e	Control box	REC TT-76	TT-76(*)/GGC	TB-1
W18 ^e	Control box	SEND TT-98	TT-98(*)/FG	Binding posts
W19 ^e	Control box	REC TT-98	TT-98(*)/FG	Binding posts
W20	Control box	POWER INPUT	Vehicle bulkhead	(+) 28 VDC
W21	Control box	AUDIO	AM-1780/VRC	J-503
W22	Control box	REMOTE	M577A1	Remote binding posts
W23	MX-7778/GRC	OUTPUT 2	W-4	10-229935-2P
			W-12	10-229935-2P

<i>Cable No.</i>	<i>From</i>	<i>Connection</i>	<i>To</i>	<i>Connection</i>
W24	MD-522(*)/GRC	AUX (J5)	RCV/SEND SWITCH	N/A
W25 ^a	R-442/VRC	ANT	R-442/VRC	Whip ant
W26	TT-76()/GGC	POWER INPUT (TB)	Inverter	Power output
TT-98(*)/FG ^b	TT-98(*)/FG	N/A	Inverter	Power output
Power Cable				
CX-10171/U ^a	AM-3349/GRC	ANT	Whip antenna	Antenna connector

^a Used only when AN/VRC-47 is installed.

^b Part of TT-98(*)/FG.

^c W-27

c. In the AN/VSC-3 (with MK-2488/G) (fig 2-1.2) and the AN/VSC-3A (with MK-2488/G) (fig. 2-1.3), cable W15 is connected to the interconnecting box J-4024/U.

d. In the AN/VSC-3 (with MK-2488/G) (fig. 2-1.2) and the AN/VSC-3A (with MK-2488/G) (fig.

2-1.3), cables W16, W17, W18, and W19 are connected from the interconnecting box J-4024/U. In the AN/VSC-3A (with MK-2488/G, W18 and W19 must be replaced with SC-C-960024 cable assembly. (Not supplied with MK-2488/G or AN/VGC-74.)

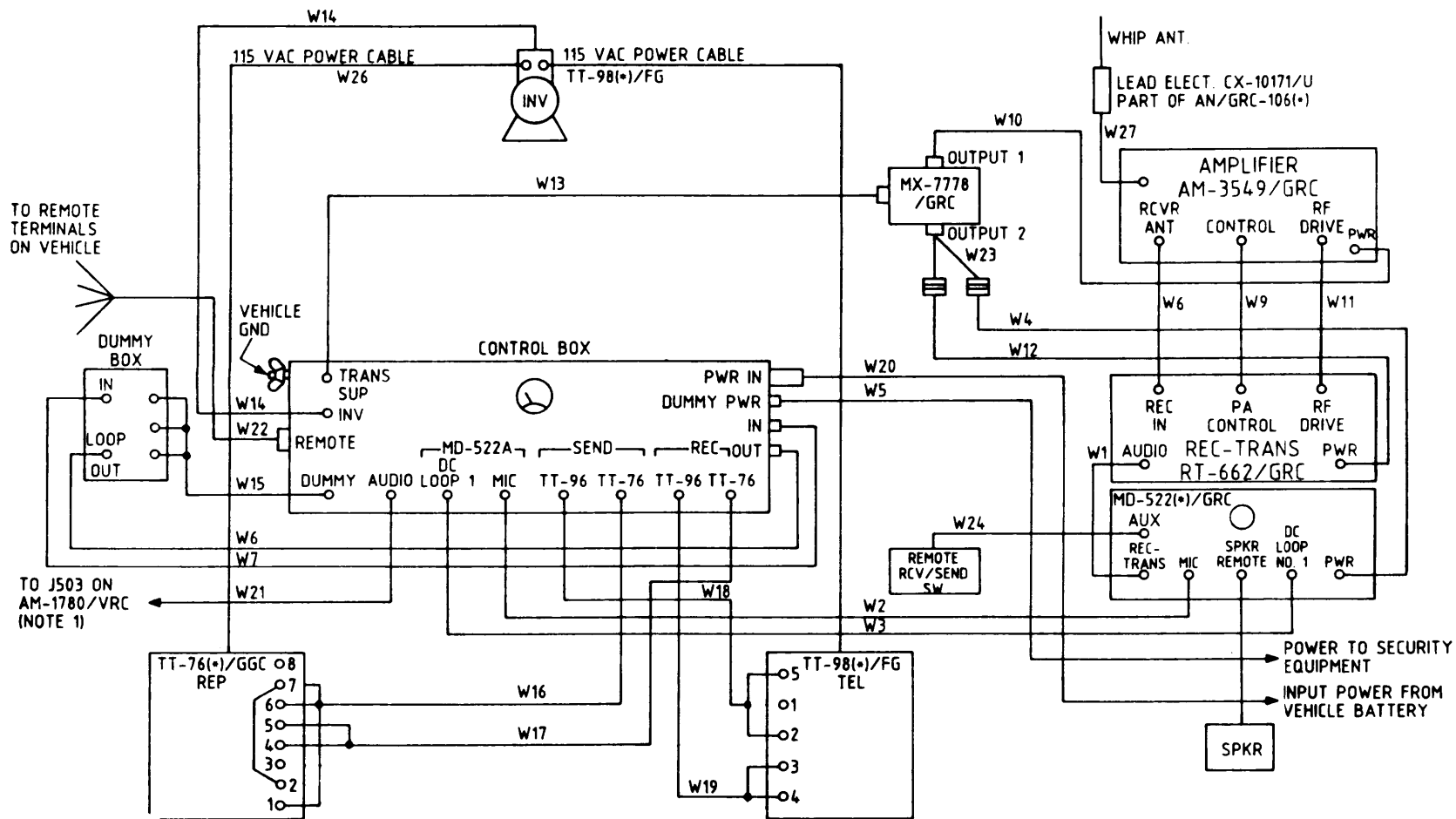

NOTES:

1. FOR REMOTE OPERATION, REPLACE W21 WITH LOCAL CONTROL C-434/GRC (P/O GRA-6)
2. FOR LOCAL OPERATION ON CW OR VOICE WITHOUT AN/VIC-1 INTERCOM SYSTEM, REPLACE W21 WITH H-33/PT HEADSET, KY-116/U TELEGRAPH KEY OR M29/U MICROPHONE.
3. REMOTE RCV/SEND SWITCH CABLE (W24) SHOULD BE CONNECTED TO AUX RCVR AUDIO (J8) ON MD-522(+)/GRC. REPLACE PLUG IF NECESSARY NSN5938-00-905-4701.

Figure 2-1. Cabling diagram (AN/VSC-3 only).

Section II. INSTALLATION PROCEDURES

2-3. Siting.

When selecting a site for communication, consider the following:

- a. Select the highest accessible point within the designated area.
- b. Avoid a location near sources of electrical interference such as: power lines, radar equipment, and field hospitals.
- c. If enemy jamming is probable, select a site which places nearby obstructions such as hills, metal buildings, or bridges between the probable sites of enemy jamming transmitters and the M577A1.

2-3.1 Camouflage Procedures.

WARNING

During combat or simulated combat conditions when the AN/VSC-3 must be camouflaged and metal poles are used to support camouflage netting make certain that these poles are positioned at a minimum of 4 feet away from the whip antenna to avoid accidental contact between the poles and the antenna.

When the AN/VSC-3 is operated using the whip antennas (fig. 1-7) and a requirement exists to camouflage the AN/VSC-3 installation, perform the following procedures:

- a. General camouflage instructions are contained in TM 5-200. However, if Radar Scattering Screen (NSN 1080-00-103-1246) is available, proceed as follows:
 - (1) Make a flap by cutting a circular area approximately 270 degrees in the garnish (vinyl) material to form a 16-inch diameter hole in the material. DO NOT CUT THE NETTING.
 - (2) Lay the garnish flap back to expose the netting.
 - (3) Temporarily secure the flap to the screen with the plastic tape provided in the camouflage repair kit (NSN 1080-00-108-1114).
 - (4) Pass the whip antenna through the center of the hole in the garnish material. Maintain an 8-inch radius between the whip antenna and the garnish material.
 - (5) When erecting the poles to support the camouflage screen, place the poles at least 4 feet from the whip antenna.
- b. When the mission is completed and the camouflage screen is removed, reposition the garnish material flap in its original position and repair with the plastic tape.

2-4. Antenna Installation

When Antenna AN/GRA-50 is to be used, install it in accordance with the procedures outlined in TM 11-5820-467-15. When whip antenna is to be used, remove the antenna mast sections from the antenna storage bag and install them as shown in figure 1-7 and discussed in *a* through *f* below.

- a. Assemble the five section whip antenna (TM 11-5820-520-12) by screwing the three Mast Sections MS-116A together, Mast Section MS-117A onto the top Mast Section MS-116A, and Mast Section MS-118A onto Mast Section MS-117A.
- b. Place the plastic antenna sheath over MS-118A with the large opening pointed toward Mast Section MS-116A and slide it down the assembled whip antenna.
- c. Screw Mast Section MS-116A of the assembled whip antenna into the AB-652/GR Mast Base.
- d. Slide the plastic antenna sheath down over the AB-652/GR as far as it will go.
- e. Bend the whip antenna and slide the tie-down clamp, with rope attached, down the antenna to the top of Mast Section MS-117A.
- f. The whip antenna may be placed in a tie-down position by pulling on the free end of the tie-down rope until the top of the whip antenna is 8 or 9 feet from the ground and then tying the tie down rope to any convenient point on the rear of the M577A1.

2-5. Installation and Removal of Security Equipment (AN/VSC-3 and AN/VSC-3A only).

CAUTION

Be sure the MD-522(*)/GRC is turned off before disconnecting wires or cables from the dummy box or security equipment

a. Installation.

- (1) Set the ON-OFF switch on the MD-522(*)/GRC to the OFF position, and set the BLACK-RED switch on the AN/VSC-3 control box to the RED position.
- (2) Connect a jumper cable (fig. 1-10) between binding posts E2 and E4 at the rear of the security equipment.
- (3) Connect shorting plugs (stored in the security device carrying case) to LOOP IN-2 and LOOP OUT-2 receptacles on the rear panel of the security equipment.
- (4) Place the security equipment on its mounting base (fig. 1-3).
- (5) Disconnect the three color-coded banana plugs from the dummy box (fig. 1-4). Connect them to the security equipment as follows:
 - (a) White banana plug to E1.
 - (b) Black banana plug to E3.

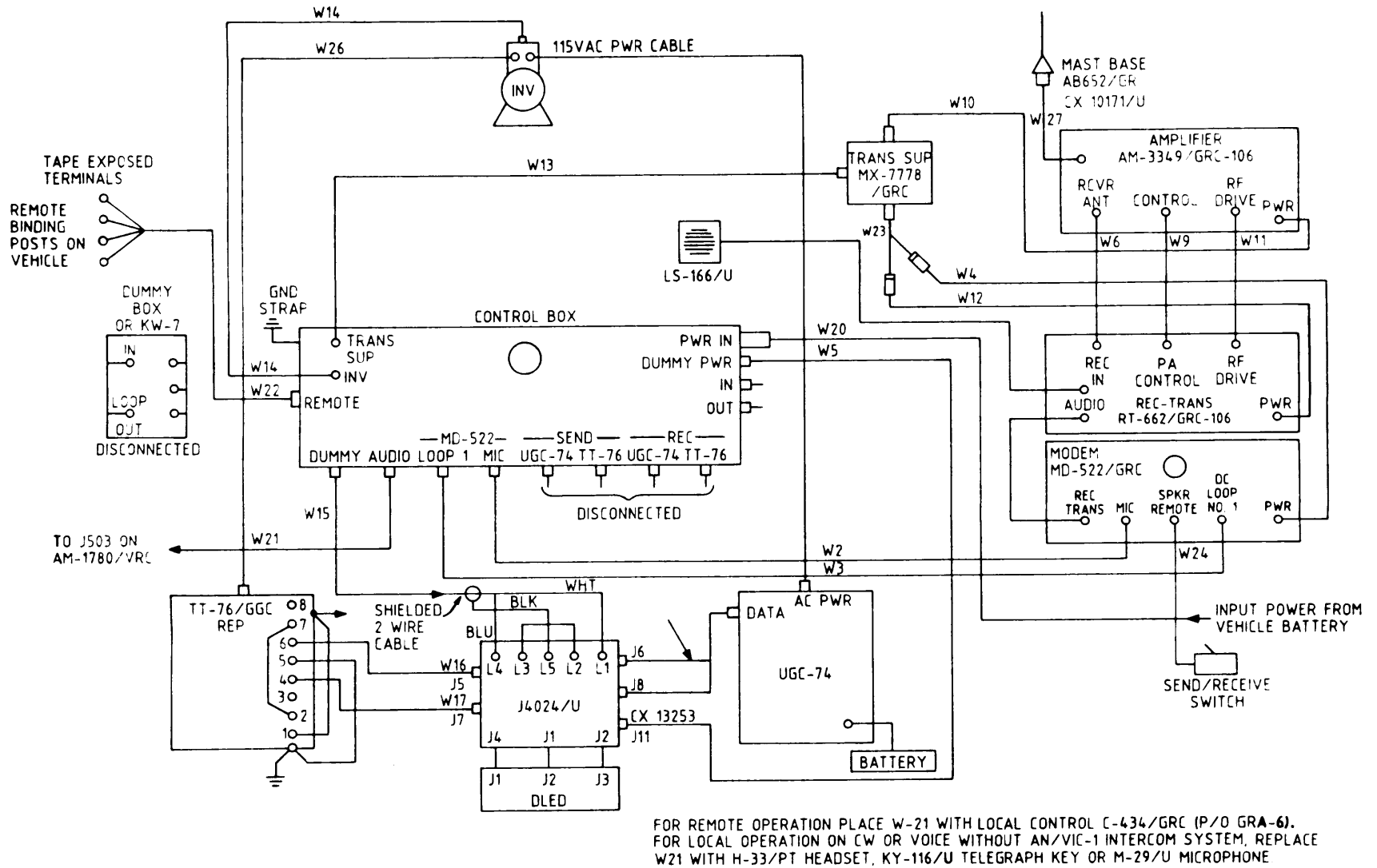

Figure 2-1-3 Cabling diagram, AN/VSC-3A (with MK 2488/G)

(c) Blue banana plug to E5.

(6) Disconnect W-7 from the dummy box LOOP IN receptacle and reconnect it to J3 of the security equipment.

(7) Disconnect W-6 from the dummy box LOOP OUT receptacle and connect it to J7 of the security equipment.

(8) Connect the free end of cable W-5 to the 24 VDC INPUT receptacle on the rear panel of the security equipment.

(9) Clamp the equipment to the mounting base.

(10) Install TT-623(*)/GGC and 5,600-ohm resistor on TT-76(*)/GGC (para 3-8f).

b. Removal.

(1) Set the ON-OFF switch on the MD-522(*)/GRC to the OFF position, and set the BLACK-RED switch on the AN/VSC-3 control box to the BLACK position.

(2) Disconnect the three color-coded banana plugs from the security equipment and connect them to their like color-coded banana jacks on the dummy box (fig. 1-4)..

(3) Disconnect W6 from J7 of the security equipment and connect it to the dummy box LOOP OUT receptacle.

(4) Disconnect W-7 from J3 of the security equipment and connect it to the dummy box LOOP IN receptacle.

(5) Disconnect power cable W-5 from the 24 VDC INPUT connector of the security equipment.

(6) Remove the security equipment from the mounting base.

(7) Remove the jumper cable (fig. 1-10) from the binding posts at the rear of the security equipment.

(8) Remove TT-523(*)/GGC and 5,600-ohm resistor from TT-76(*)/GGC and restore TT-76(*)/GGC for nonsecure operation.

2-6. Mast AB-155/U Erection

(figs. 2-2 through 2-6)

If used, determine the position for the antenna to be erected. Determine the direction the antenna is to radiate. Stretch an assembled antenna along the ground in the desired position and direction. Place the antenna in a position (consider lead-in length) to allow proper connection of the antenna to the equipment (AN/VSC-3) after it is raised. Plan to erect the end masts several feet beyond the end insulators. The center mast should be at the coaxial connector and offset 3 feet from the line of the antenna (fig. 2-6). A center mast will not be required if the overall antenna is less than 120 feet long. Erect each Mast AB-155/U as follows:

a. Place Mast AB-155/U at each mast location and remove Cover CW-124/GRA-4 from Carrying Device MX-387/GRA-4.

b. Drive the stake of Mast Base AB-154/U into the ground at the desired mast location with the swivel end pointing 45 degrees from the line of the antenna (fig. 2-4). If the ground is soft or sandy, place the mast base plate (fig. 2-6) on the ground and push it down firmly; then drive the stake of Mast Base AB-154/U through the hole in the mast baseplate.

c. Align the large ends of Mast Sections MS-44 toward the mast base. Connect the first mast section (fig. 2-4) to Mast Base AB-154/U; add the second and third mast sections. Place a Guy Plate MX-378/U over the third section. Add the fourth and fifth sections; place a second MX-378/U over the fifth section. Add three more mast sections, and place a third MX-378/U over the last section.

d. Slip a Guy Fastener MX-379/U over each guy stake before it is driven into the ground. Drive a guy stake (back guy stake) into the ground at the junction of the fifth and sixth MX-44 (25 feet from Mast Base AB-154/U). Place the front and side guy stakes 90 degrees apart as shown in figure 2-4. Use a guy rope to measure the distance between the mast base and the front and side guy stakes. If the ground is soft or sandy, use the wooden stakes instead of the aluminum stakes, and loop the guys over the stakes. Do not use the MX-379/U.

e. Fasten four Guys MX-383/GRA-4 to top Guy Plate MX-378/U, four Guys MX-381/GRA-4 to center Guy Plate MX-378/U, and the remaining four Guys MX-382(GRA-4 to bottom Guy Plate MX-378/U. Fasten the guys by snapping the fastener at the end of each guy into one of the four holes located 90 degrees apart on the MX-378/U. Next, carry the free ends of the three back guys to a side guy stake to measure their correct length. Fasten these guys to the back guy stake with Guy Fastener MX-379/U. Connect both sets of side guys to their respective side guy stakes, and remove slack by adjusting Slide Fastener FT-9 (fig. 2-4). Do not overtighten because the mast may bend. Keep the three front guys together, and stretch them along the mast toward the front guy stake.

f. Remove Halyard MX-516/GRA-4 from the carrying device, and attach the snap fastener on the pulley to the unused hold in the top Guy Plate MX-378/U. Slip the rope through the pulley (fig. 2-6), and tie the ends of the rope near the mast base to keep the rope from running through the pulley when raising the mast.

g. To raise the mast (fig. 2-5), three men are required. Man No. 1 holds the front guys and pulls steadily on them, keeping slightly more tension on the top guy to bow the mast slightly while being raised. Man No. 2 takes a position near the mast base and holds Mast Base AB-154/U in the designated position as the mast is raised. Man No. 3 stands near the top end of the mast and raises it

as he walks toward the mast base.

h. Adjust the guys until the mast is vertical. Whenever a guy is tightened, the opposite one may have to be loosened slightly to keep the mast from bowing.

2-7. Antenna Raising

When operating within the frequency range of 2.0 to 4.0 MHz, the length of the antenna wire requires the use of three 40-ft Masts AB-155/U or other convenient supports for each antenna. At frequencies above 4.0 MHz, only two masts or supports are required for each antenna. Each antenna should be positioned broadside to the direction of transmission or reception.

a. If a center (AB-155/U) mast is used, attach the fastener on Halyard MX-516/GRA-4 to the coaxial connector.

b. Fasten Halyard (if used) MX-516/GRA-4 on each end mast to the antenna wire by attaching one end of a wire (approximately 15 inches of antenna wire) to the end strain insulator, and the other end to the fastener assembly on Halyard MX-516/GRA-4.

c. Pull the antenna wire into position with Halyards X-516/GRA-4. Tie the rope to the mast to prevent the weight of the antenna wire from pulling the loose end of the rope back through the pulley. Figure 2-6 shows a doublet antenna completely erected.

2-8. Installation of Security Equipment, AN/VSC-3 (with MK-2488/G and AN/VSC-3A with MK-2488/G).

CAUTION

Be sure that the MD-522(*)/GRC is turned off before disconnecting wires/cables from the dummy box or security equipment.

NOTE

Installation instructions in TM 11-5815-616-13 must be implemented before the TSEC/KG-84A and companion Interconnecting Box J-4024/U can be installed.

The application of installation instructions will change the mounting base on the curbside wall with addition of Mounting Base MT-6442/G and Mount, Resilient MT-6444/VSC-3. (fig 1-7.1) One TSEC/KG-84A with Interconnecting Box J-4024/U will fit in the space formerly used by the TSEC/KW-7. The MK-2488/G Installation Kit does not contain the TSEC-KG-84A. The COMSEC equipment must be requisitioned from your COMSEC supply source. Once you have received your TSNC/KG-84 or TSEC/KG-84A, you install it with the companion

Interconnecting Box J-4024/U (from the Installation Kit) onto the Mounting Base. Prepare, and install the security equipment assemblage as follows:

a. Interconnecting Box J-4024/U.

(1) On the rear panel, operate the POWER SOURCE switch to 28VDC.

(2) On the front panel, operate the POWER switch to OFF.

(3) On the front panel, operate the HOME COPY switch to OFF.

(4) On the front panel, operate the TRANSMITTER switch to POS 1.

(5) On the rear panel, remove the captive connector receptacle covers.

6. Installation and Preparation of interconnecting Box J-4024/U in AN/VSC-3 (with MK-2488/G). (fig. 2-1.3)

(1) Rest the interconnecting box on top of its base in a manner which permits access to rear panel.

(2) Disconnect one end of cables W16, W17, W18, and W19 from SEND receptacles TT-98 and TT-76 and REC receptacles TT-98 and TT-76 on the AN/VSC-3 Control Box assembly, and route to rear of J-40234/U.

(3) Disconnect the W15 banana plugs from jacks on shelter dummy box assembly.

(4) Replace the W5 cable removed with the TSEC/KW-7 and connect one end to Control Box DUMMY PWR receptacle. Route other end of cable to rear of J-4024/U.

(5) Remove two banana plugs from the MK-2488/G kit and fabricate a short jumper wire or approximately 6 inches in length.

(6) Measure distance from rear panel or J-4024/U to any convenient frame mounting bolt for grounding. Cut grounding wire to this length. Strip both ends of wire, and splice one end to the Black W15 banana plug wire.

(7) Connect the removed cable connectors to rear panel receptacles of the J-4024/U as follows:

- (a) W16 and J5
- (b) W17 to J7
- (c) W18 to J6
- (d) W19 to J8
- (e) W5 to J11
- (f) Black banana of W15 to GND
- (g) Blue banana of W15 to L4
- (h) White banana of W15 to L1
- (i) Jumper wire between L2 to L3
- (j) Ground wire to shelter frame.

(8) Proceed to para 2-8d.

(9) At the rear panel of the interconnecting box J-4024/U place the POWER SOURCE switch to 28 VDC position.

(10) Proceed to para 2-8 d.

c. Installation and Preparation of Interconnecting Box J-4024/U to AN/VSC-3A (with MK-2488/G). (Fig. 2-1.3)

(1) Rest the interconnecting box on top of the base MT-6442/G in a manner which permits access to rear panel.

(2) Disconnect one end of cable (Branched) CX-13253 from SEND UGC-74 and REC UGC-74 and cables W16 and W17 from SEND TT-76 and REC TT-76. Route disconnected cable end to rear panel area of J-4024/U.

(3) Disconnect the W15 banana plugs from jacks on shelter dummy box assembly. Route disconnected cable end to rear area of J-4024/U.

(4) Replace the W5 cable removed with the TSEC-KW-7, and connect one end to Control Box DUMMY PWR receptacle and route other end to rear area of J-4024.

(5) Remove two banana plugs from MK-2488/G kit and fabricate a short jumper wire with one banana plug at each end of a 6 inch wire.

(6) Prepare a grounding wire cut to the length to reach the nearest frame ground bolt in rack frame. Splice one end to the W15 Black wire banana plug and secure other end to frame ground.

(7) Connect the removed cable plugs and connectors to the rear panel of the J-4024 as follows:

- (a) W16 to J5
- (b) W17 to J7
- (c) CX-13253 P2 to J8 (Red)
P3 to J6 (Black)
P1 to DATA connector on
AN/UGC-74.
- (d) W5 to J11
- (e) Black banana of W15 to GND
- (f) Blue banana of W15 to L4
- (g) White banana of W15 to L1
- (h) Jumper wire from L2 to L3
- (i) Ground wire to shelter frame.

(8) At the rear of the J-4024/U interconnecting box, set the POWER SOURCE switch to 28 VDC.

(9) Set the switches on the AN/UGC-74A(V)3 to:

PARITY	INHIB
STATE	KSR
REC MODE	48V
XMIT MODE	70 A
BAUD	50 OR 75
CLOCK INT/EXT	int
CLOCK ±	
FIGURES	J
SIGNAL	NRZ
STOP BITS	1
MODE	BAUDOT

(10) Proceed to para. 2-8d.

d. Preparation of Digital Loop Encryption Device (DLED) KG-84 or KG-84A.

(1) Obtain a TSEC/KG-84(*)/U from COMSEC supply facility.

(2) Have COMSEC technician strap the equipment internally and set the controls as outlined in Figure 2-1.4. There are two models of the KG-84 available but the interface box J-4024/U is designed to operate with the KG-84 (plain) model. The internal strapping are necessary for the KG-84A to emulate the operation of the KG-84 (plain). In addition, insure that the COMSEC technician removes the Type 1 MODEM card from the KG-84 prior to use with the J-4024/U.

NOTE

The AN/UGC-74 can not use its full capabilities for digital Baud rates above that required for standard teletypewriter Baudot code speeds. The J-4024/U limits the Baud rates. In addition, the Teletypewriters must have their main shaft and motor gears set to the selected baud rate for the system.

(3) Rest the TSEC-KG-84(*) on mounting base MT-6442/G in a manner which permits access to rear.

e. Installation of Digital Loop Encryption Device (DLED) KG-84 or KG-84A.

(1) Select DLED Black Signal cable assembly, CX13517, DLED Power cable assembly, CX-13316, and Red Signal cable assembly CX-13316 from installation kit MK-2488/G.

(2) Connect the cables between J-4024/U and TSEC/KG-84 as follows:

- (a) J1 to J2 on KG-84
- (b) J3 to J3 on KG-84
- (c) J4 to J1 on KG-84

(3) After preparation of the DLED, KC-84(*)/U, inspect the cable connecting the J-4024/U and KG-84(*) to insure that they are clear of any obstruction. Prepare a length of stranded wire 18 inches long and connect one end to the grounding terminal on the KG-84(*)/U, and the other end to a convenient frame grounding screw.

(4) Slide the J-4023/U and the KG-84 to the rear of the MT-6442/G until the rear retainer bullets of the mount are secured to the mating inserts. Clamp the front wing nut retainers to the projections on the J-4024/U and the KG-84(*)/U, and tighten.

(5) Place power switch on front panel to OFF position.

BD	FCTN	STRAPPING	
A1		BAL <input type="checkbox"/>	UNBAL <input checked="" type="checkbox"/>
A2		BAL <input type="checkbox"/>	UNBAL <input checked="" type="checkbox"/>
A5		ENBL <input checked="" type="checkbox"/>	DSBL <input type="checkbox"/>
A5		ENBL <input checked="" type="checkbox"/>	DSBL <input type="checkbox"/>
A9		BAL <input type="checkbox"/>	UNBAL <input checked="" type="checkbox"/>
A9		SGL <input checked="" type="checkbox"/>	DBL <input type="checkbox"/>
A9		GATED <input type="checkbox"/>	CONT <input checked="" type="checkbox"/>

BD	PLUG	STRAPPING	
A1	P2	<input type="checkbox"/>	J6-J7 J8-J9 <input checked="" type="checkbox"/>
	P3	<input type="checkbox"/>	J5-J6 J9-J10 <input checked="" type="checkbox"/>
	P4	<input type="checkbox"/>	J11-J12 J14-J15 <input checked="" type="checkbox"/>
A2	P5	<input type="checkbox"/>	J12-J13 J15-J16 <input checked="" type="checkbox"/>
	P6	<input type="checkbox"/>	J17A <input checked="" type="checkbox"/>
	P6	<input checked="" type="checkbox"/>	J17B <input type="checkbox"/>
A5	P2	<input type="checkbox"/>	J6-J7 J9-J10 <input checked="" type="checkbox"/>
	P3	<input checked="" type="checkbox"/>	J20-J22 <input type="checkbox"/>
	P4	<input type="checkbox"/>	J21-J22 <input type="checkbox"/>
A9	P5	<input type="checkbox"/>	J15-J16 J12-J13 <input checked="" type="checkbox"/>
	P6	<input type="checkbox"/>	J18-J19 <input checked="" type="checkbox"/>
	P6	<input type="checkbox"/>	J17-J18 <input type="checkbox"/>
A6	P2	<input checked="" type="checkbox"/>	J8-J9 <input checked="" type="checkbox"/>
	P3	<input type="checkbox"/>	J5-J7 <input checked="" type="checkbox"/>
	P3	<input type="checkbox"/>	J5-J6 <input type="checkbox"/>
A9	P4	<input type="checkbox"/>	J14-J15 J11-J12 <input checked="" type="checkbox"/>
	P5	<input type="checkbox"/>	J15-J16 J12-J13 <input checked="" type="checkbox"/>
	P4	<input checked="" type="checkbox"/>	J7-J8 <input type="checkbox"/>
A9	P2	<input type="checkbox"/>	J7 <input checked="" type="checkbox"/>
	P3	<input checked="" type="checkbox"/>	J6 <input type="checkbox"/>
	P3	<input checked="" type="checkbox"/>	J11-J12 <input type="checkbox"/>
A9	P4	<input checked="" type="checkbox"/>	J12-J13 <input type="checkbox"/>
	P4	<input checked="" type="checkbox"/>	J8-J9 <input type="checkbox"/>
A9	P4	<input checked="" type="checkbox"/>	J9-J10 <input type="checkbox"/>

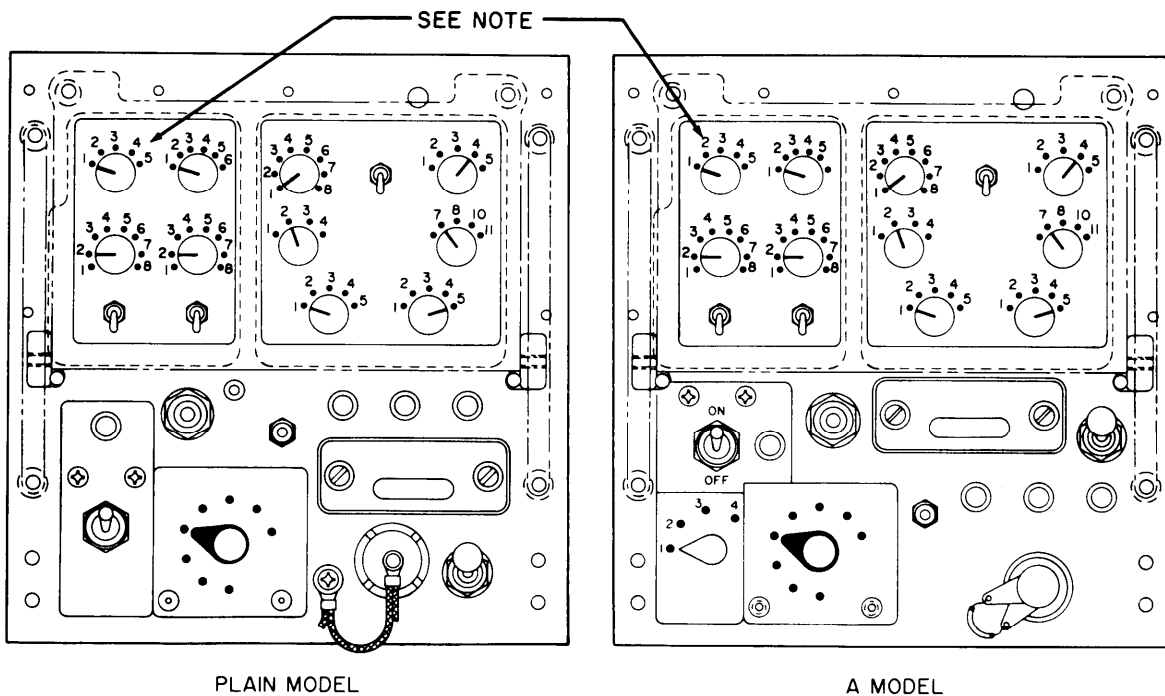

WARNING

The switch settings and strapping are to be made ONLY by qualified COMSEC technicians. The AN/VSC-3 Radio Operator will not touch these required settings.

NOTE

- Remove Type 1 Modem card from unit prior to use with the MK-2488/G.
- Switch to be changed to position 2 if unit is to be used as slave, position 1 is for master unit.

Figure 2-1.4 Control settings and strapping options

2-9. Secure Teletypewriter Testing Procedures in the AN/VSC-3 with MK-2488/G, and AN/VSC-3A with MK-2488/G). These equipments will be operated in the secure mode.

a. Test setup, AN/VSC-3 (with MK-2488/G).

(1) Check to see that the COMSEC equipments have been prepared installed and connected as directed in paragraph 2-8.

(2) Check that all power switches in the AN/VSC-3(*) are set to OFF.

(3) perform starting procedures for the AN/VSC-3 as given in para. 3-8 and 3-9 thru 3-9.2 of this manual. As a part of this procedure, insure that teletypewriter TT-76(*)/GGC is set up for 20 ma. neutral operation. Set the Control Box BLACK-RED switch to RED.

(4) Operate the main circuit breakers on the Control Box to ON. The lamp on the Control Box should light.

(5) perform the starting procedures for the TT-76(*)/GGC and the TT-98(*)/TG in the AN/VSC-3 (with MK-2488/G).

(6) Set up a second AN/VSC-3 at a distant site, and perform all the preceding procedures on it up to this point. This radio set will be referenced as Set No. 2 in the following steps.

(7) Set up the two AN/VSC-3 radios with a voice channel to permit coordination of the following tests.

CAUTION

Adjust the radio receiver sensitivity at both stations to prevent blocking (saturation condition). Set the transmitter and modulator for SSB voice first and test the communication.

(8) Set up both radios sets for ONE WAY REVERSIBLE (OWR) operation on a select frequency.

NOTE

In OWR operation, only one transmitter is energized at a time. When there is no transmission, the MD-522 Modem will keep the teletypes running closed (Steady Mark).

The transmitters are not radiating energy until the transmitter is keyed on by use of SEND/REC switch. For functional description of the MD-522 unit, refer to Chapter 5 of TM 11-5805-387-15-1.

(9) Set the TRANSMIT switch of the J-4024/U to Pos 1, and HOME COPY switch to OFF.

(10) Turn on the transmitter and send a test message from the keyboard or transmitter-distributor of the TT-76(*)/GGC.

(11) Observe the home copy on the page printer TT-98(*)/FG at station 1.

(12) A COPY of the message should be received on the TT-76(*)/GGC at station 2. This may be confirmed by use of the voice orderwire channel of the radios.

(13) Turn the radio control switch at station 1 to Receive. Have station 2 transmit a test message from his TT-76(*)/GGC.

(14) A copy of the message should be printed on the TT-98(*)/FG at station 1.

b. Test setup, AN/VSC-3A (with MK-2488/G).

(1) Check to see that the COMSEC equipments have been prepared, installed, and connected as directed in paragraph 2-8.

(2) Check that all power switches in the AN/VSC-3A are set to OFF.

(3) perform starting procedure for the AN/VSC-3A as given in para. 3-8 and 3-9 thru 3-9.2 of this manual. Insure that the AN/UGC-74(*) is prepared as in para. 2-8c (9) and that the TT-76/GGC is properly set up for operation. Set the Control Box BLACK-RED switch to RED.

(4) Operate the main circuit breakers on the Control Box to ON. The lamp on the Control Box should light.

(5) perform the starting procedure for the TT-76(*)/GGC and the TT/UGC-74A in the AN/VSC-3 (with MK-2488/G).

(6) Set up a second AN/VSC-3A at a distant site, and perform all of the preceding procedures up to this point. This radio set will be Set No. 2 in the following steps.

(7) Set up the two AN/VRC-3 radios with a voice channel to permit coordination of the following tests.

CAUTION

If necessary, adjust the radio receiver sensitivity to prevent strong signal blocking of the channel.

(8) Set up both radios for ONE-WAY REVERSIBLE (OWR) operation.

NOTE

Both radio transmitters share the same frequency, therefore, one transmitter at a time may be keyed by the teletype-transmitter. With both transmitters off, the .MD-522 will hold the teletype equipment on steady MARK.

(9) Set the TRANSMIT switch of the J-4024/U to position 1, and the HOME COPY switch to OFF.

(10) Turn on the SEND/REC switch on the control box to SEND. Transmit a test message from the keyboard or transmitter-distributor of the TT-76(*)/GGC .

(11) Observe that the amber light on the KG-84A is lit during transmission.

(12) Observe the Indicator lamp on the AN/UGC-74(*)/(V)3 to insure the message is entering the buffer of the equipment. Remember that once the buffer is full, then the copy will print on the printer unit. If a one-line buffer operation is selected, the equipment will print one line at a time.

(13) The AN/UGC-74 is set up to print home copy at this time and the TT-76 is transmitting.

(14) Confirm by voice communication over the channel whether the message was received properly on the distant set AN/UGC-74.

(15) Turn the control box switch to REC and have set No. 2 transmit a test message on his TT-76/GGC. Observe the results on the AN/UGC-74 at set NO. 1.

(16) Once this test is completed, turn all equipment power to OFF, and prepare for communications mission.

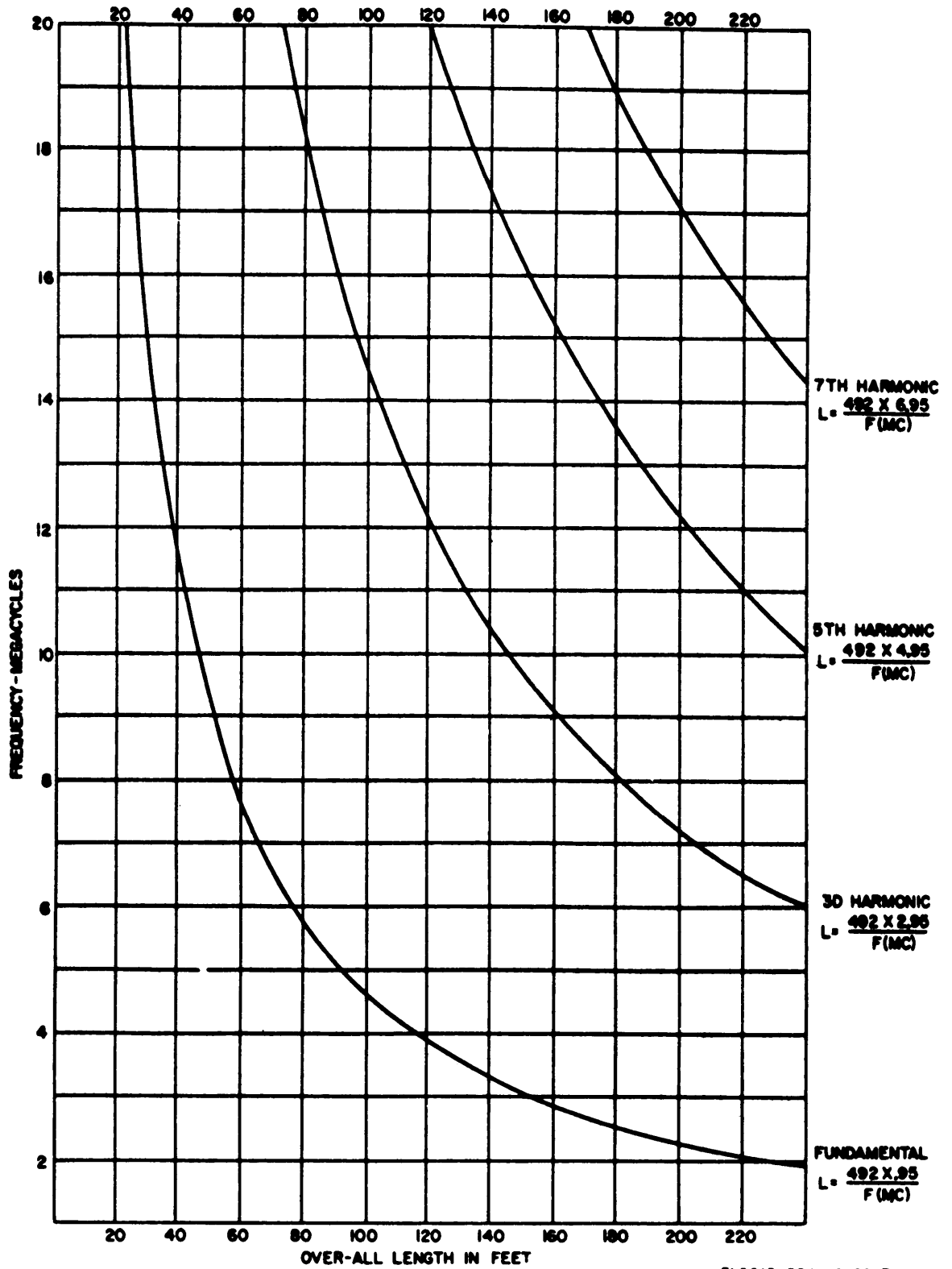

EL5815-334-12-C5-TM-1

Figure 2-2. Graph of antenna length versus frequency.

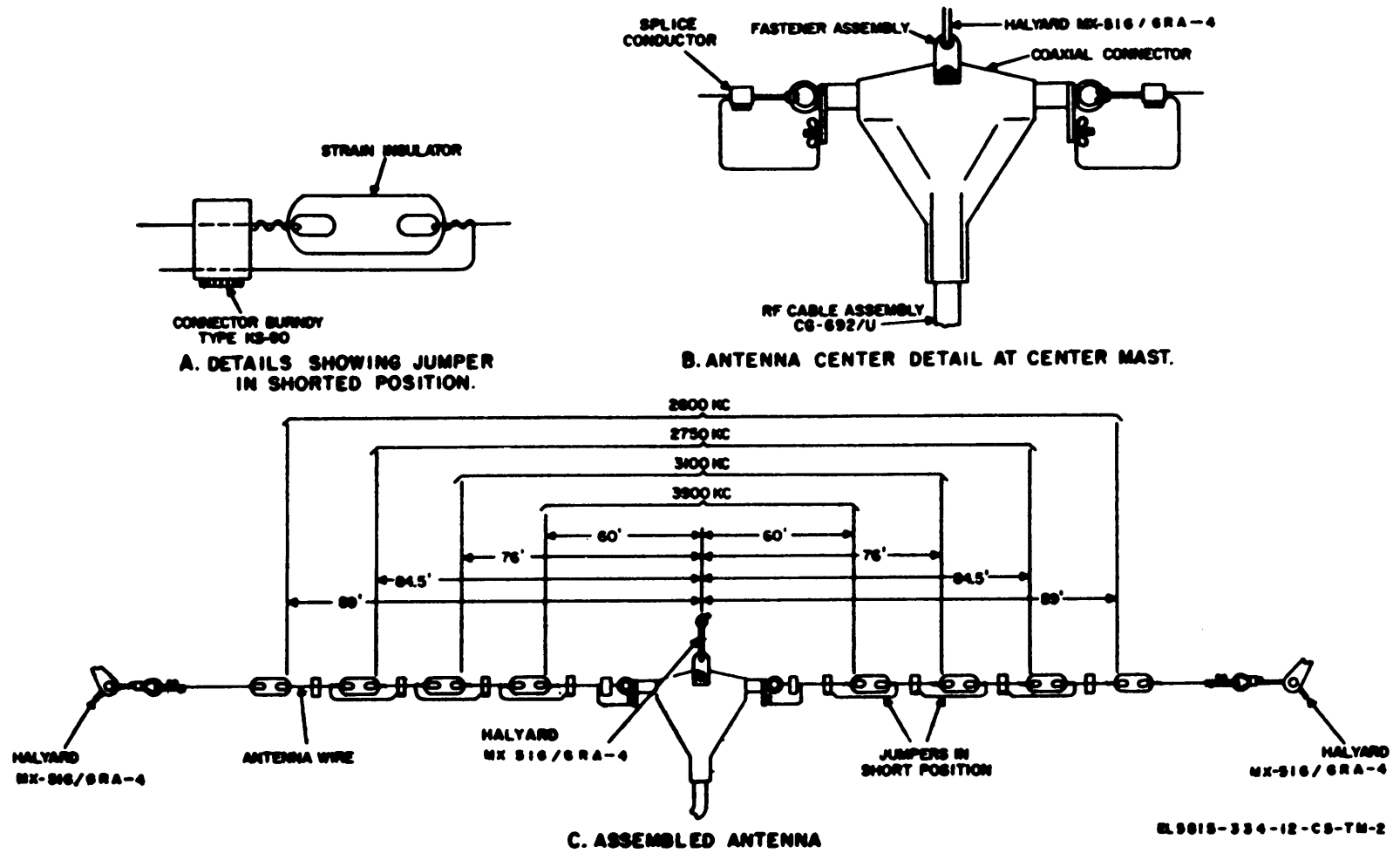

Figure 2-3. Construction and assembly of doublet antenna.

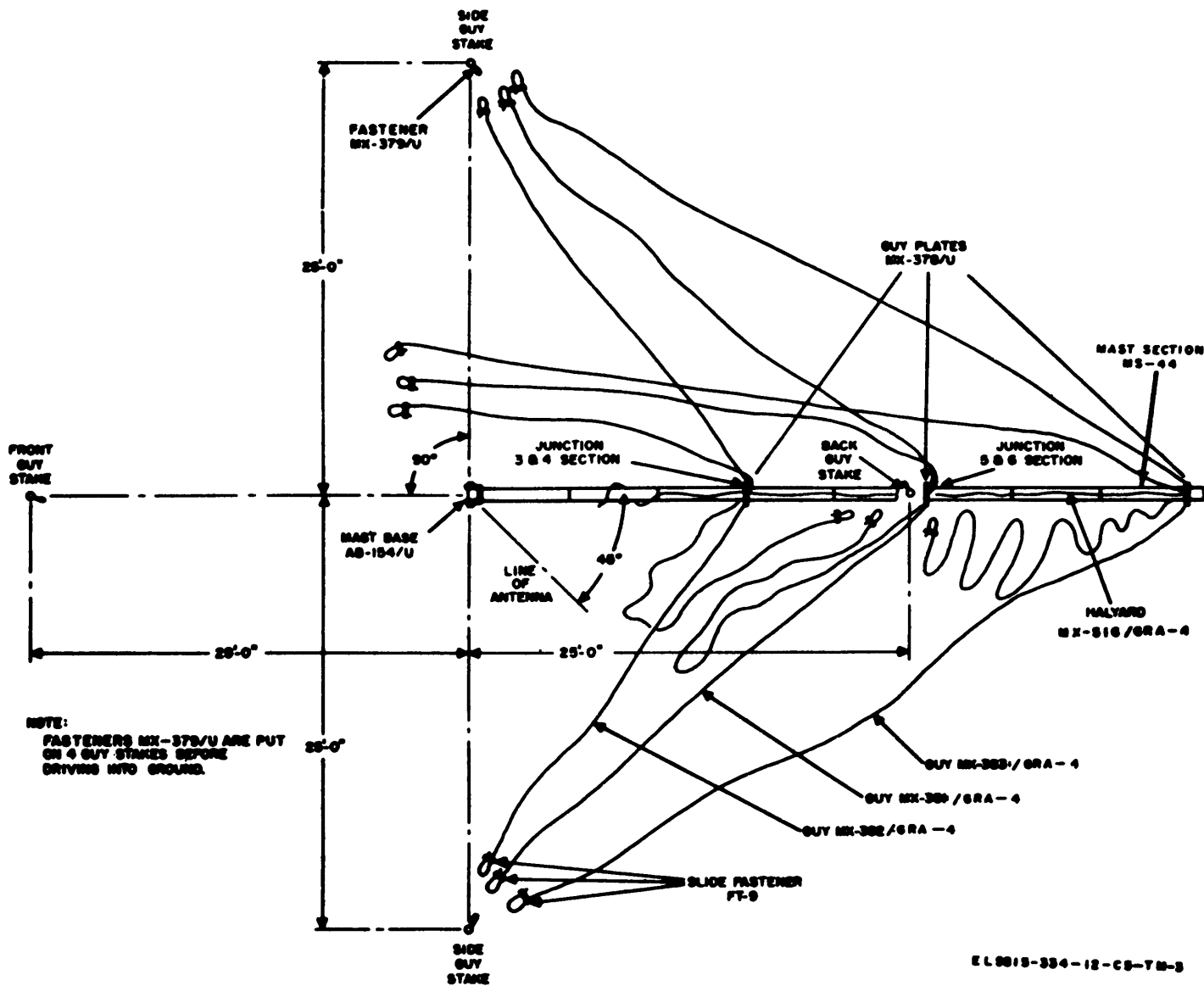

Figure 2-11. Preparing Mast AB-154/U for erection.

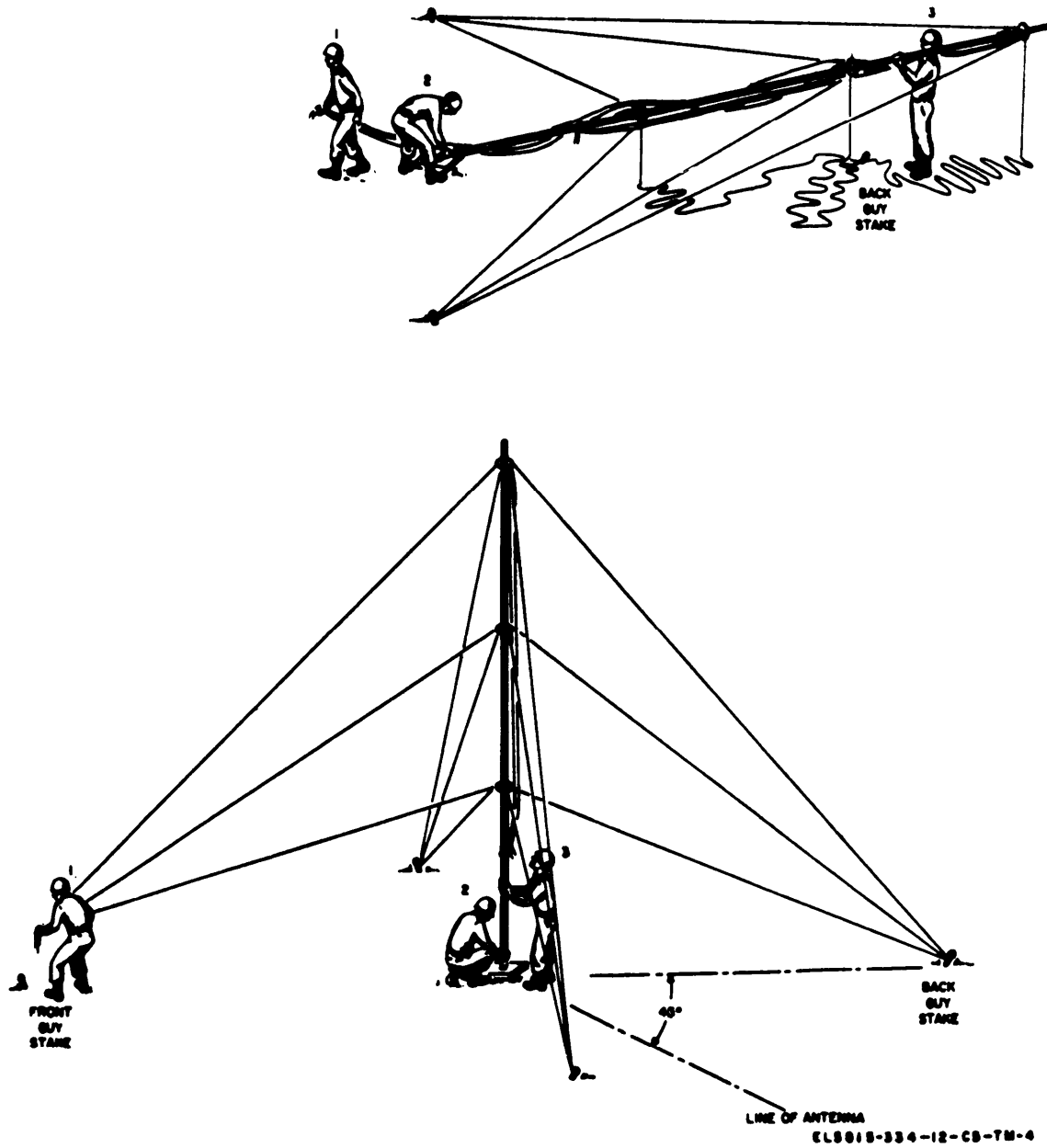
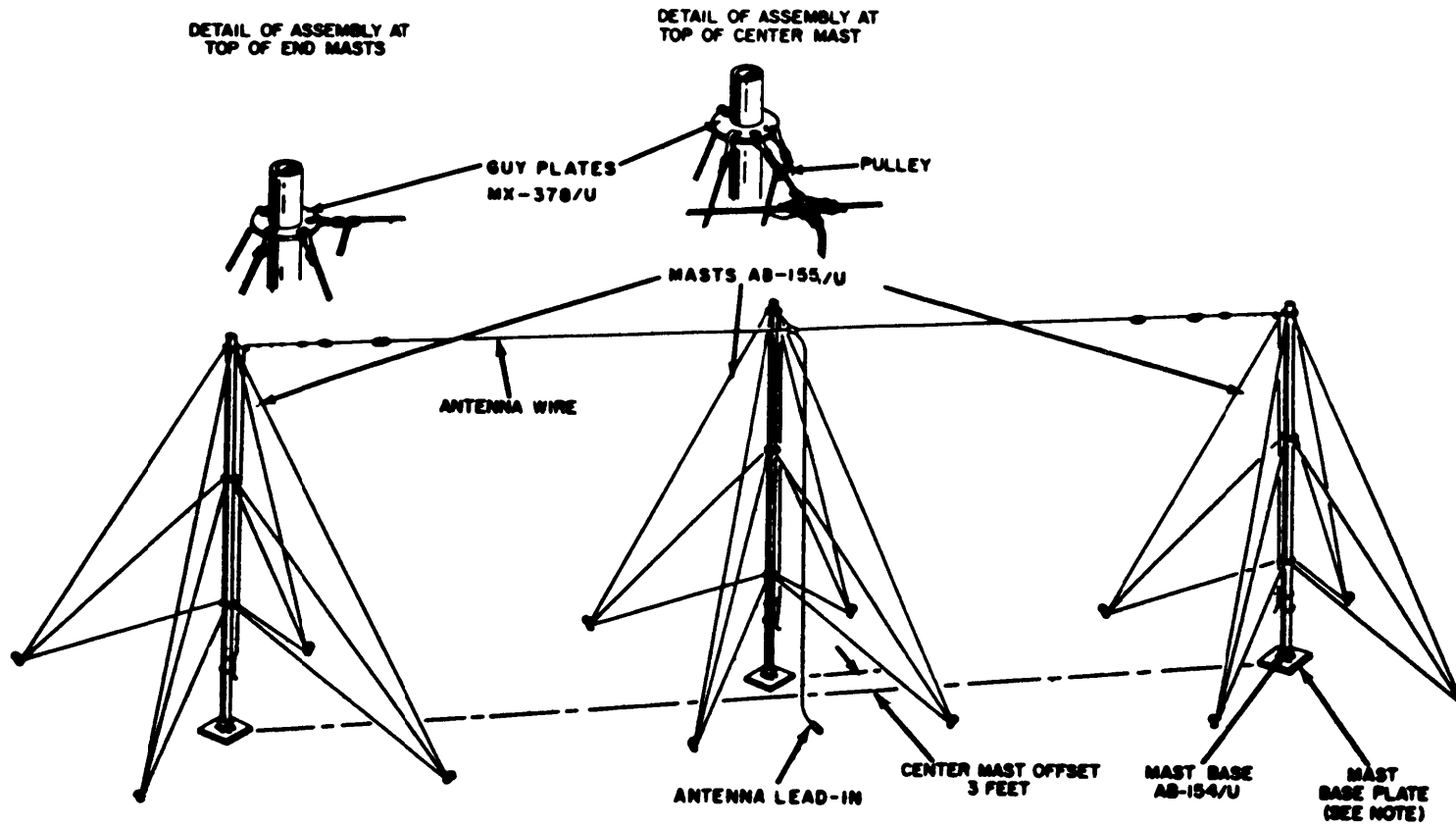

Figure 2-5. Raising assembled Mast AB-165/U.



NOTE:
THE MAST BASE PLATE IS
USED ONLY WHEN GROUND
IS SOFT OR SANDY.

EL 5815 - 334 - 12 - CB - T M - 5

Figure 2-6. Doublet antenna, erection completed.

CHAPTER 3

OPERATING INSTRUCTIONS

WARNING

Before operating this equipment make certain all requirements of TB SIG 291 are met. Injury or DEATH could result from improper or careless operation.

Section I. CONTROLS AND INDICATORS

WARNING

Be sure that the AN/GRA-50 antenna connector is disconnected from the 50 OHM LINE connector on Amplifier, Radio Frequency AM-3349/GRC-106 and that the flag switch covers the 50 OHM LINE connector when operating the AN/GRC-106(*) with the whip antenna. Injury or DEATH as well as damage to the equipment can result if this warning is not heeded.

CAUTION

Do not transmit on the AN/GRC-106(*) while tuning the equipment. Damage to the equipment can result if this caution is not heeded.

3-1. General

This section covers controls, indicators, and connectors of the AN/VSC-3 not covered in other technical manuals. In addition, paragraph 3-6

covers the combined functions of the C-2298/VRC and the CVC helmet switch (para 3-6 a). Refer to the associated technical manual (app A) for information on all other equipment.

3-2. Control Box Controls, Indicators and Connectors

(fig. 3-1)

<i>Control or indicator</i>	<i>Function</i>
MAIN circuit breakers	Two-ganged 50-ampere circuit breakers that provide overload protection and on-off control of dc power to the AN / VSC-3.
27.5 VDC indicator	Lights when MAIN circuit breakers are set to ON and dc power is applied to the AN / VSC-3.
D. C. VOLTS meter	Indicates value of dc voltage applied to the AN / VSC-3 control box.
INVERTER circuit breaker	A 20-ampere circuit breaker that provides overload protection and on-off control of dc power to the inverter.
VOICE-CW / TTY switch	In VOICE-CW position connects MD-522(*) / GRC for voice communications. In TTY position connects MD-522(*) / GRC for radio teletypewriter operation.
BLACK / RED switch	In BLACK position connects the AN / VSC for nonsecure communications. In RED position connects AN / VSC-3 for secure RTTY communications when secure equipment is installed.
NON-SECURE VOICE indicator	Lights when VOICE-CW / TTY switch is in VOICE-CW position.
LOCAL / REMOTE switch	In LOCAL position completes dc loop for operation of TT-76(*) / GGC and TT-98(*) FG in the vehicle. In REMOTE position, connects local TT-76(*) / GGC and TT-98(*) / FG dc loop in series with do loop to remote teletypewriter.
POWER INPUT connector	Connects +28 VDC side of vehicle battery power to the control box.

Control or indicator

Function

DUMMY PWR connector	Allows connection of security equipment to vehicle battery power.
LOOP IN connector	Provides connection for TT-76(*) / GGC keyboard and T.D. and TT-98(*) / FG keyboard from the control box to the dummy box or security equipment.
LOOP OUT connector	Provides connection for TT-76(*) / GGC and TT-98(*) / FG selector magnets from the control box to the dummy box or security equipment.
REC-TT-76 connector	Connects TT-76(*) / GGC selector magnets to the control box.
REC-TT-98 connector	Connects TT-98(*) / FG selector magnets to the control box.
SEND-TT-76 connector	Connects TT-76(*) / GGC keyboard to the control box.
SEND-TT-98 connector	Connects TT-98(*) / FG keyboard and T.D. to the control box.
MD-522-MIC connector	Connects MD-522(*) / GRC, MIC input to the control box.
MD-522-DC LOOP-1 connector	Connects MD-522(*) / GRC, DC LOOP 1 connector to the control box.
AUDIO connector	Provides for connection of an AM-1780 / VRC or a handset or microphone to the control box for voice operation of the MD-522(*) / GRC and AN / GRC-106(*). Provides for connection of Telegraph Key KY-116 / U for cw operation. Provides for connection of AN / GRA-6 Local Control C-433 / GRC (P / O AN / GRA-6) for all modes of remote operation.
DUMMY connector	Connects from dummy box or security equipment banana jacks to complete teletypewriter dc loop.
REMOTE connector	Provides for connection to remote teletypewriter set and cw key.
INVERTER connector	Connects vehicle battery power to the set inverter.
TRANS SUPPRESSOR connector	Connects vehicle battery power to the Electrical Transient Suppressor MX-7778 / GRC.
GROUND terminal	Connects -28 vdc side of vehicle battery power to the control box.

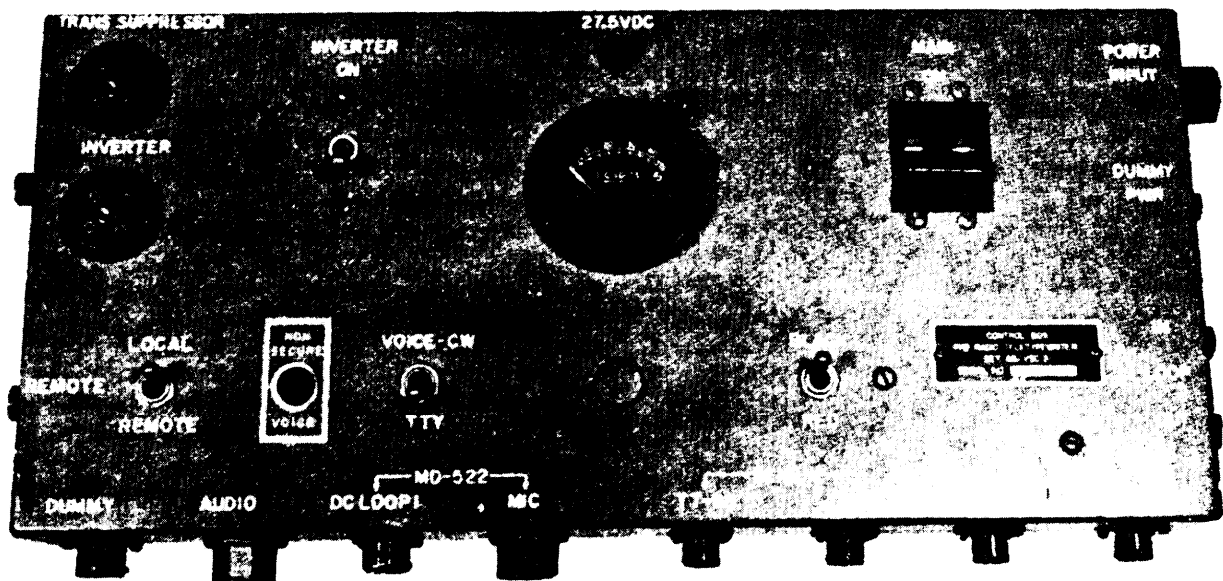

EL 5815-332-15-TM-13

Figure 3-1. Front view of AN/VSC-3 control box.

3-3. Remote Control Box Controls and Connectors
(fig. 3-2)

<i>Control or connector</i>	<i>Function</i>						
TTY binding posts (2)	Provide connection for field wire pair to remote control box for remote teletypewriter operation (fig. 3-4).						
TTY jacks (6)	Normalled-through jacks which permit insertion of remote teletypewriter equipment into teletypewriter dc loop of radio set for nonsecure teletypewriter operation.						
AUDIO connector	Provides connection of handset for remote voice operation or cw reception.						
SEND / REC switch	<table border="0" style="width: 100%;"> <tr> <td style="text-align: left;"><i>Sw pos</i></td> <td style="text-align: right;"><i>Effect</i></td> </tr> <tr> <td>SEND</td> <td>Keys AN / GRC-106(*) from remote site, during remote teletypewriter transmissions.</td> </tr> <tr> <td>REC</td> <td>Places AN / GRC-106(*) in receive mode, from remote site, during remote teletypewriter reception.</td> </tr> </table>	<i>Sw pos</i>	<i>Effect</i>	SEND	Keys AN / GRC-106(*) from remote site, during remote teletypewriter transmissions.	REC	Places AN / GRC-106(*) in receive mode, from remote site, during remote teletypewriter reception.
<i>Sw pos</i>	<i>Effect</i>						
SEND	Keys AN / GRC-106(*) from remote site, during remote teletypewriter transmissions.						
REC	Places AN / GRC-106(*) in receive mode, from remote site, during remote teletypewriter reception.						
Pendent plug	Permits connection of remote control box to remote Control C-433 / GRC (p / o AN / GRA-6) for remote voice operation.						

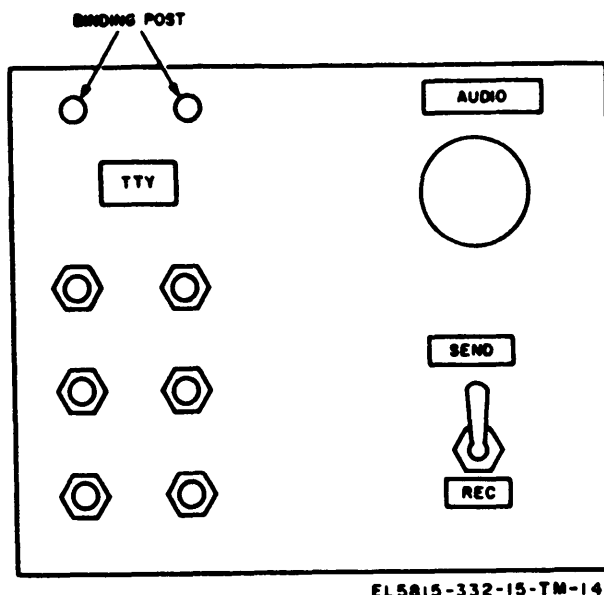
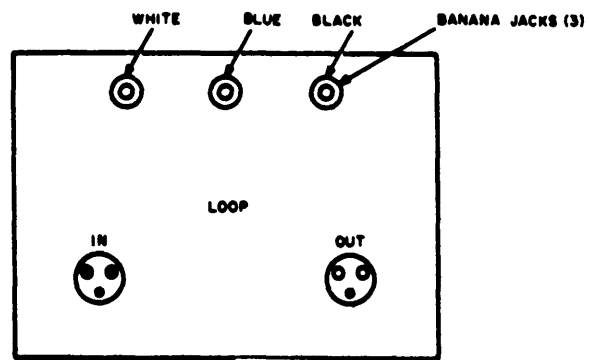

Figure 3-2. Radio Teletypewriter Set AN/VSC-3 remote control box, front panel controls and connectors.

3-4. Dummy Box Connectors
(fig. 3-3)

<i>Control or connector</i>	<i>Function</i>
LOOP IN connector	Provides connection for TT-76(*) / GGC and TT-98(*) / FG keyboards to control box.
LOOP OUT connector	Provides connection for TT-76(*) / GGC and TT-98(*) / FG selector magnets to control box.
Banana jacks (3)	Provide connection for the TTY dc loop from control box to dummy box.



EL6015-332-15-TM-15

Figure 3-3. Radio Teletypewriter Set AN/VSC-3 dummy box, front panel connectors.

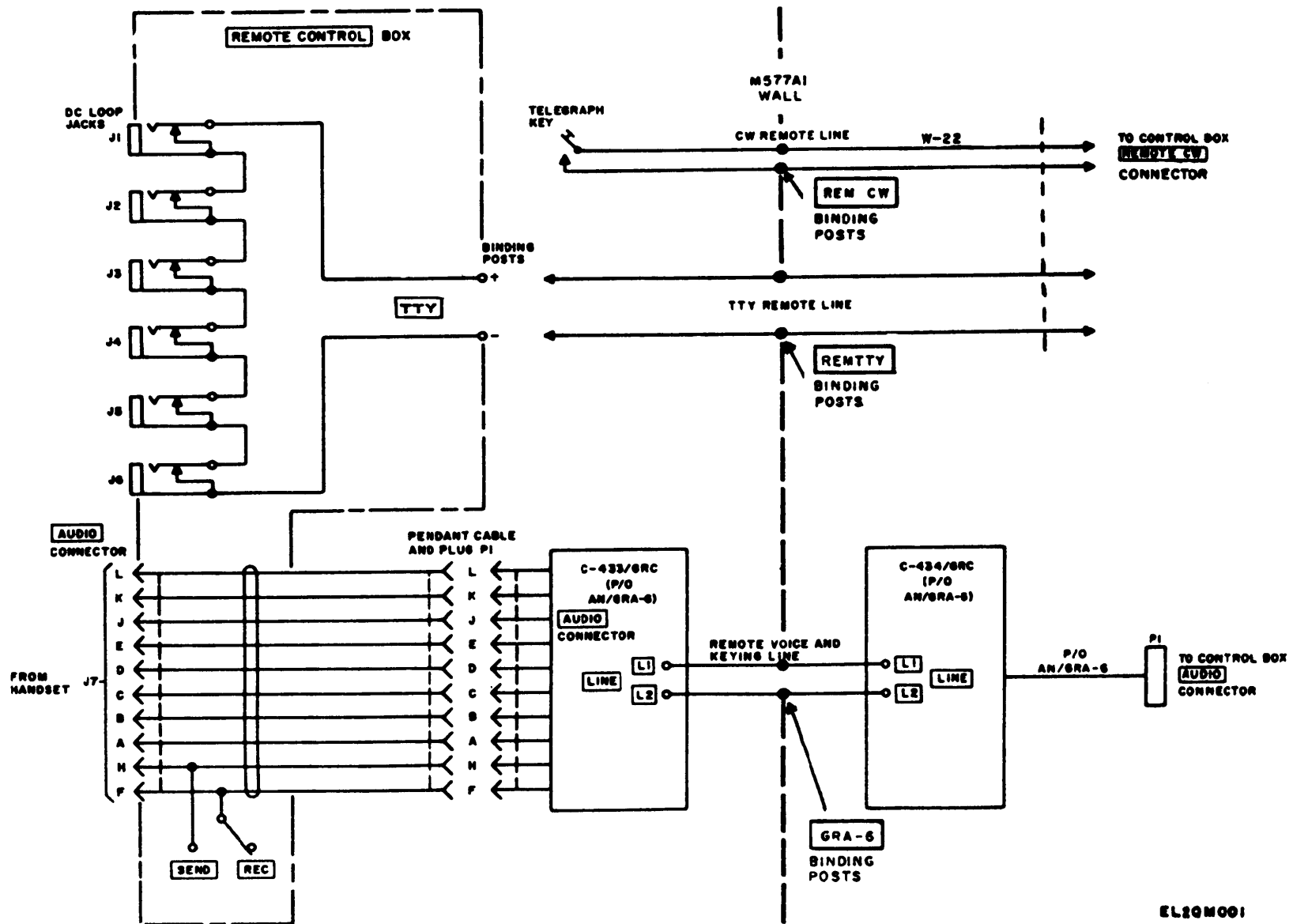

Figure 3-4. Radio Teletypewriter Set AN/VSC-3 remote operation, functional diagram.

**3-5. Electrical Transient Suppressor
MX-7778/GRC
(fig. 1-1)**

The two ganged circuit breakers on the front of the MX-7778/GRC provide on-off control and transient voltage spike and overload protection for the MD-522(*)A/GRC and AN/GRC-106(*).

**3-6. Combined CVC Helmet and
C-2298/VRC Functions**

Intercommunication Set AN/VIC-1(V) is usually installed in M577A1 vehicles for communications between crew members and voice operation of radio equipment. When the AN/VIC-1(V) is connected to the AN/VSC-3 control box, Radio Set AN/GRC-106(*) (part of the AN/VSC-3) may be voice operated from any of the AN/VIC-1(V) operator positions. In addition, Radio Set AN/VRC-47 may be installed in the vehicle and operated with the AN/VIC-1(V). The operation of the AN/VIC-1(V) when connected to the AN/VSC-3 control box and AN/VRC-47 is given in a, b, and c below. If the AN/VRC-47 is not installed in the vehicle disregard control position for operation of that radio equipment.

a. General. Three CVC helmets and three C-2298/VRC's are used to operate the AN/VIC-1(V); one each at each of the three operating positions. The CVC helmet has a three position switch whose positions are Ics, Neutral, and Radio (spring loaded). The five switch positions of the C-2298/VRC are described in TM 11-5820-401-10. The combined functions of these controls for each of the three operating positions are described in b and c below.

b. Crew Commander's Operating Position. Operation of the crew commander's C-2298/VRC and CVC helmet switches are given in (1) through (13) below. In all cases the C-2298/VRC switch position is given first, followed by a slash and the CVC helmet switch position. Additional conditions that apply to the communications system follow the switch functions.

(1) ALL/Radio: Enable transmission with sidetone on RT-524/VRC.

(a) Transmission cannot be interrupted by other operators control of AN/VIC-1(V) (Interphone Override).

(b) Voice sidetone can be interrupted by other operators (InterPhone Override).

(2) ALL/Neutral: Enables reception on RT-524/VRC and R-442/VRC. Reception can be interrupted by other operators control of AN/VIC-1(V) (Interphone Override).

(3) ALL/Ics: Enables intercommunications on AN/VIC-1(V) with other operator positions, including InterPhone Overnde control except when other operators C-2298VRC is set to C.

(4) A/Radio Same as (1) above.

(5) A/Neutral: Enables reception only on **RT-524/VRC. Reception can be interrupted by other operators control of AN/VIC-1(V) (Interphone override).**

(6) A/Ics: Same as (3) above.

(7) INT ONLY/Ics: Same as (3) above.

(8) B/Radio Same as (1) above.

(9) B/Neutral: Enables reception only on R-442/VRC. Reception can be interrupted by other operators control of AN/WC-1(V).

(10) B/Ics: Same as (3) above.

(11) C/Radio: Enables transmission without sidetone on AWGRC-106(*).

(a) Transmissions cannot be interrupted by other operators control of AN/VIC-1(V).

(b) Transmissions can be interrupted by AN/VSC-3 voice lockout circuits (security equipment).

(12) C/Neutral: Enables reception on AN/GRC-106(*). Reception can be interrupted by other operators control of AN/WC-1(V).

(13) C/Ics: Same as (3) above.

c. Teletypewriter and Driver Operating Positions
The functions of the teletypewriter and driver operator position controls are the same as the functions given for the crew commander operating position controls, except as follows:

(1) The teletypewriter and driver C/Ics position cannot be used for InterPhone Override of intercommunications between positions.

(2) The am. transmission of the teletypewriter or drive operator can be interrupted by other operator operation of the AN/VIC-1(V) when in ALL/Radio, A/Radio, and B/Radio.

Section II. OPERATING INSTRUCTIONS

CAUTIONS

1. *Before* applying primary power to the AN/VSC-8, start the M577A1 engine or auxiliary power unit (TM 9-2300-224-10/3/2). Failure to do the above can cause serious damage to the radio equipment.
2. When teletypewriter transmission is not taking place, the auxiliary RCV/SEND switch, the MD-522(*)/GRC SEND-RCV switch, and the remote control RCV-SEND switch must be set to RCV to prevent transmitter from being continuously keyed.

3-7. Scope of Operating Procedures

The procedures given in paragraphs 3-8 through 3-13 cover local AN/VSC-3 operation including the use of Intercommunications Set AN/VIC-1(V). Paragraph 3-14 gives the connections and procedures for: voice operation using Remote Control C-433/GRC; radio teletypewriter operation using Teletypewriter Set TT-4C/TC (or a similar set); and cw operation using a telegraph key, from a remote position. Paragraph 3-15 covers the operation of the teletypewriter under conditions of sand or heavy dust. Paragraph 3-18 gives the procedures to store set items and prepare for movement of the M577A1 vehicle. Throughout the procedures, refer to applicable equipment manuals (app A) for control location and detail operation of standard equipment.

3-8. Preliminary Operating Procedures

Before starting any of the equipment, perform the procedures given in a through f below.

a. Control Box (fig. 3-1)

- (1) Set MAIN circuit breaker to OFF.
- (2) Set INVERTER circuit breaker to OFF.

b. MX-7778/GRC (fig. 1-1). Set circuit breakers to OFF.

c. Radio Set AN/GRC-106(*). Set PRIM PWR switch on the AM-3349/GRC-106 to OFF. Set SERVICE SELECTOR switch on RT-662/GRC to OFF.

d. Radio Teletypewriter Modem MD-522 (*)/GRC. Set ON-OFF switch to OFF.

e. Teletypewriter Set TT-98(*)/FG.

- (1) Set MOTOR switch to OFF.
- (2) Set Light switch to OFF.
- (3) Adjust TT-98(*)/FG LINE CURRENT control fully clockwise (for minimum resistance).
- (4) Set LINE selector switch to 20 MA position

(see fig. 105 for TT-98(*)/FG).

f. Teletypewriter, Reperforator-Transmitter TT-76(*VGGC (fig. 1-8).

- (1) Set POWER switch to OFF.
- (2) Set MOTOR switch to OFF.
- (3) Set LIGHT switch to OFF.
- (4) Check the current in the bias circuit by following the instructions in TM 11-5815-238-12.

(5) Open the TT-76(*)/GGC cover and insure that the following has been performed, if TTY security equipment is to be installed. If not, skip (5), (6) and (7).

(a) A 5600-ohm resistor connected to the power supply and terminal unit BIAS TEST MA terminals, in place of the shorting strap.

(b) The SIGNAL/BIAS switch on the power supply and terminal unit is in the 60 MA position (60 MA is the correct position when using the 5600-

ohm resistor in (a) above, even though the system is set for 20 MA).

(c) The plug from the selector magnet cable is in the socket marked 20 MA.

(6) Close the set cover.

(7) Insure that Device, Low Level Signaling TT-523(*)/GGC is correctly installed on the set, behind the transmitter distributor. Insure that the plugs are connected the bracket is secured under the binding post on the side of the set cover.

g. Interconnecting Box J-4024/U.

- (1) Set POWER switch to OFF.
- (2) Set TRANSMITTER switch to pos. 1.
- (3) Set HOME COPY switch to REC 1 or REC 2.

3-9. Teletypewriter Starting Procedures

Start the M577A1 engine or auxiliary power used (TM 9-2300-224-10) and then perform the procedures below

a. On the control box (fig. 3-1), perform the following:

(1) Set the MAIN circuit breakers to ON and observe that the 27.5 VDC indicator lights and the dc voltmeter indicates 27.5 VDC.

(2) Set the INVERTER breaker to ON and observe that the inverter is operating.

(3) Set the VOICE-CW/TTY switch to TTY.

(4) If the AN/VSC-3 is to be operated in a nonsecure mode, set the BLACK/RED switch to BLACK. If the AN/VSC-3 is to be operated in a secure mode, set the BLACK/RED switch to RED.

(5) Set the LOCAL/REMOTE switch to LOCAL.

b. ON THE MD-522(*)/GRC (fig. 1-1) open the control cover to expose additional controls and complete the following:

(1) Set the ONE WAY-DUPLEX switch to ONE WAY.

(2) Set the RECEIVE switch to NORM.

(3) Set the METER FUNCTION switch to DC LOOP NO. 1

(4) Set the DC LOOP NO. 1 switch to 20 MA.

(5) Set the SCOPE INTENSITY control fully counterclockwise.

(6) Set the BFO control to its midscale position.

(7) Set the AUDIO GAIN control fully counterclockwise.

(8) Set the MODE SELECTOR switch to VOICE .

(9) Set the SEND-RCV switch to RCV.

(10) Set the AUTO MARK HOLD switch to ON.

(11) Set the SQUELCH SENS control to the fully clockwise position.

(12) Set the ON-OFF switch to ON.

c. Set the MX-7778/GRC circuit breakers (fig. 1-1) to ON.

d. Set the auxiliary RCV/SEND switch (on the shelf, (fig. 1-8)) to RCV.

e. On the TT-98(*)/FG (fig. 1-3), set the MOTOR switch to ON, LIGHT switch to ON, and SEND-LOCK switch to SEND.

f. On the TT-76(*)/GGC, set the POWER ON/OFF switch to ON, MOTOR ON/OFF switch to ON, LIGHT ON/OFF switch to ON, KEYBOARD SEND/LOCK switch to SEND, and SELECTOR switch to position 1.

g. Send a line of RYs on the TT-98(*)/FG keyboard and check that the TT-98(*)/FG is printing and that the TT-76(*)/GGC is printing and perforating tape in response.

h. Send a line of RYs on the TT-76(*)/GGC keyboard and check that the TT-76(*)/GGC is printing and perforating tape and that the TT-98(*)/FG is printing in response.

i. Insert a prepunched tape into the TT-76(*)/GGC transmitter-distributor and set the transmitter-distributor START-STOP lever to START. Check that the TT-76(*)/GGC is printing and perforating tape and that the TT-98(*)/FG is printing in response. Set the transmitter-distributor START-STOP lever to STOP.

j. Set the TT-76(*)/GGC SELECTOR switch to position 2. Set the transmitter-distributor START-STOP switch to START. Check that the TT-76(*)/GGC is not printing and perforating and that the TT-98(*)/FG is receiving the tape message. Check that the TT-76(*)/GGC keyboard can be used to punch and print local OFF LINE tape.

k. When using the AN/UGC-74A(V)3, the following procedures must be followed:

NOTE

Before operating the AN/UGC-74A(V)3 the following self test must be made.

(1) Remove the front cover. Insure that the ON/OFF switch is in the OFF position.

(2) If a loop back plug (SM-B-91600) is available disconnect the clock and data cable from the J1 connector on the rear panel of the AN/UGC-74A(V)3. Replace the cable with the loop back plug. If the plug is not available do not disconnect the clock and data cable from the J1 connector. Place a jumper (using banana jacks) from the B to the C connectors on the Dummy box. This creates a loop back circuit to the AN/UGC-74A(V)3.

(3) Release the combination case latches and extend the terminal out on its slides until

the stop locks engage. (Use caution while doing this as the cables must go through the case). The internal controls and switches are available at this time.

(a) Set the internal controls on the interface assembly as follows.

(b) PARITY switch to ODD

(c) STATE switch to ICT

(d) REC MOD switch to LO DATA

(e) XMIT MOD switch to LO DATA

(f) BAUD RATE switch to 75

(g) CLOCK INT/EXT switch to INT

(h) CLOCK +/- switch to +

(i) FIGURE S/J switch to S

(j) SIGNAL NRZ/DIO switch to NRZ

(k) STOP BITS switch to 1

(l) MODE switch to ASCII

(m) SELF TEST switch to ON

(n) Press the stop locks and return the terminal back into the combination case. Secure with its latches.

(4) Turn the power switch to ON, on the AN/UGC-74A(V)3. Copy lamps are on and all other lamps are off. The terminal prints the operational state message as follows:

```
SYSTEM INITIALIZED
SWITCH STATE = ICT
OPERATIONAL STATE = ICT
OPERATION CAPACITY = FULL
MODE = ASCII
STOP BITS = 1
BAUD RATE = 75
END OF LINE OPTION = OD OD OA
SPACE OPTION = OFF
LINE LENGTH = 80
LINE FEEDS = 1
RECEIVE ENVELOPE
  OPTION = 565A 43 5A 43: 4E 4E 4E 4E
TRANSMIT ENVELOPE
  OPTION = 56 5A 43 5A 43: 4E 4E 4E 4E
  7F 7F 7F 7F 7F 7F 7F 7F 7F
  7F 7F 7F
PARITY OPTION = ODD
CAPITOL LETTER OPTION = ON
```

(5) If at any time, a test fails, the system will print out a "FAIL" message and cite the assembly being tested at the time of the failure. All testing stops during self test when a test fails. Notify organizational maintenance.

(6) Perform lamp test by pressing and holding PARITY RESET switch. All indicator lamps will remained illuminated as long as the PARITY RESET switch is pressed.

(7) Perform keyboard test by pressing every key on the keyboard. Insure that the keys do not stick or bind, and the terminal responds properly for every key depression.

3-9.1. Teletypewriter Starting Procedure for the AN/VSC-3 (with MK-2488/G)

Check to see that the equipment has been connected for secure operation.

NOTE

The TT-76(*)/GGC and the TT-98(*)/FG must be set up for 50 or 75 baud operation. Insure that the motor and mainshaft gears are installed to match the selected baud rate.

- a. Repeat the procedures in paragraphs 3-9a through 3-9f.
- b. Set the TRANSMITTER switch to position 2 and the HOME COPY switch to REC 1 on the J-4024/U. Send a line of "RY" on the TT-98(*)/FG keyboard. The transmitted message should print on the TT-76(*)/GGC reperforator.
- c. Set the TRANSMITTER switch on the J-4024/U to position 1.
- d. Insert a prepunched tape into the TT-76(*)/GGC transmitter-distributor and set the START-STOP lever to START. Check that the message is printing on the TT-98(*)/FG. Set the transmitter-distributor START-STOP lever to STOP.
- e. Set the TT-76(*)/GGC SELECTOR switch to position 2. Set the transmitter-distributor START-STOP switch to START. Check that the TT-76(*)/GGC is not printing and perforating and that the TT-98(*)/FG is receiving the tape message. Check that the TT-76(*)/FG keyboard can be used to punch and print local OFF LINE tape.

3-9.2. Teletypewriter Starting Procedures for the AN/VSC-3A (with MK-2488/G).

a. Perform the following procedures in the sequence as shown:

NOTE

Before operating the AN/UGC-74A(V)3, (TM 11-5815-602- 12), the following self test must be made.

- (1) Remove the front cover. Insure that the ON/OFF switch is in the OFF position.
- (2) If a loop back plug (SM-B-91600) is available, disconnect the clock and data cable from the J1 connector on the rear panel of the AN/UGC-74A(V)3. Replace the cable with the loop back plug. If the plug is not available, do not disconnect the clock and data cable for the J1 connector. Place a jumper (using banana jacks) from the B to the C connectors on the Dummy box. This creates a loop back circuit to the AN/UGC-74A(V)3.

(3) Release the combination case latches and extend the terminal out on its slides until the stop locks engage. (Use caution while doing this as the cables must go through the case). The internal controls and switches are available at this time.

- (a) Set the internal controls on the interface assembly as follows:
 - (b) PARITY switch to INHIB.
 - (c) STATE switch to KSR.
 - (d) REC MOD switch to 48V.
 - (e) XMIT MOD switch to 70 pa.
 - (f) BAUD RATE switch to 50 or 75 (same as TT-76(*)/GGC).
 - (g) CLOCK INT/EXT switch to INT.
 - (h) CLOCK +/- switch to -.
 - (i) FIGURE S/J switch to J
 - (j) SIGNAL NRZ/D10 switch to NRZ.
 - (k) STOP BITS switch to 1.
 - (l) MODE switch to BAUDOT.
 - (m) SELF TEST switch to ON..
 - (n) Press the stop locks and return the terminal back to the combination case. Secure with its latches.

b. Perform the following procedures in sequence as follows:

(1) Turn the power switch to ON, on the AN/UGC-74A(V)3. Copy lamps are on all other lamps are off. The terminal prints the operational state message as follows:

```

SYSTEM INITIALIZED
SWITCH STATE = KSR
OPERATIONAL STATE = KSR
OPERATION CAPACITY = FULL
MODE = BAUDOT
STOP BITS = 1
BAUD RATE = 50 or 75
(same as TT-76(*)/GGC).
END OF LINE OPTION = OD OD OA
SPACE OPTION = OFF
LINE LENGTH = 80
LINE FEEDS = 1
RECEIVE ENVELOPE OPTION =
TRANSIT ENVELOPE OPTION =
BELL OPTION = FIGURE J
    
```

(2) If at any time, a test fails, the system will print out a "FAIL" message and cite the assembly being tested at the time of the failure. All testing stops during self test when a test Fails. Notify organizational maintenance.

(3) Perform lamp test by pressing and holding PARITY RESET switch. All indicator lamps will remain illuminated as long as the PARITY RESET switch is pressed.

(4) Perform keyboard test by pressing every key on the keyboard. Insure that the keys do not stick or bind, and the terminal responds properly for every key depression.

(5) Set the TRANSMITTER switch to position 2 and the HOME COPY switch on the J-4024/U to REC 1. Send a line of RY's on the AN/UGC-74A(V)3

keyboard. The transmitted message should print on the TT-76(*)/GGC reperforator.

(6) Set the TRANSMITTER switch on the J-4024/U to position 1.

(7) Insert a prepunched tape into the TT-76(*)/GGC transmitter-distributor and set the START-STOP lever to START. Check that the message is printing on the TT-76(*)/GGC reperforator. Set the transmitter-distributor START-STOP lever to STOP.

(8) Set the TRANSMITTER switch to position 2 and the HOME COPY switch on the J-4024/U to REC 2. Send a line of RY's on the AN/UGC-74A(V)3 keyboard. The transmitted message should print on the AN/UGC-74A(V)3 printer.

(9) Set the TRANSMITTER switch on the J-4024/U to position 1.

(10) Insert a prepunched tape into the TT-76(*)/GGC transmitter-distributor and set the START-STOP lever to START. Check that the message is printing on the AN/UGC-74A(V)3. Set the transmitter-distributor START-STOP lever to STOP.

(11) Set the TT-76(*)/GGC SELECTOR switch to position 2. Set the transmitter-distributor START-STOP switch to START. Check that the TT-76(*)/GGC is not printing and perforating and that the AN/UGC-74A(V)3 is receiving the tape message. Check and the TT-76(*)/GGC keyboard can be used to punch and print local OFF LINE tape.

3-10. Radio Set AN/GRC-106(*) Starting and Tuning Procedures.

NOTE

The AM-3349/GRC-106 HV RESET switch must be in OPERATE position, whenever the AN/GRC-(*) is turned OFF or ON. References to RT-662/GRC are applicable to RT-834GRC.

a. initial Preparation for Operation.

(1) Check to see that the whip antenna is in the operating position, properly connected, and free of obstructions.

(2) Make sure that there are no obstructions blocking the AM-3349/GRC-106 air inlet and outlet vents.

(3) Connect the desired audio accessory (handset, microphone, or telegraph key) to the control box AUDIO connector.

(4) Turn the RT-662/GRC SERVICE SELECTOR switch to OVEN ON. (Allow a minimum of 10 minutes warm-up time to stabilize equipment.)

(5) Set the RT-662/GRC VOX switch to PUSH-TO-TALK.

(6) Set the RT-662/GRC SQUELCH control to OFF.

(7) Set the NOISE BLANKER switch to OFF. (Used an older RT-662/GRC only.)

(8) Set the RT-622/GRC BFO control to mid-range.

(9) Set the RT-662/GRC MANUAL RF GAIN control fully clockwise.

(10) Set the RT-662/GRC AUDIO GAIN control to mid-range.

(11) Set the RT-662/GRC FREQUENCY VERNIER switch to OFF.

(12) Set the AM-3349/GRC-106 HV RESET switch to OPERATE.

b. AN/GRC-106(*) Starting Procedure.

(1) Set the RT-662/GRC SERVICE SELECTOR switch to STANDBY and the AM-3349/GRC-106 PRIM POWER switch to ON, and allow 90 seconds for warm-up of the AM-3349/GRC-106. Observe that the AM-3349/GRC-106 blowers are energized and that the signal level meter on the RT-662/GRC indicates in the extreme right portion of the meter scale. (If above indications are abnormal, refer to table 4-2, items 1 and 2, TM 11-5820-520-12.)

(2) Set the RT-662/GRC SERVICE SELECTOR switch to SSB NSK (or any operate mode FSK, AM or CW). Signal level meter will return to extreme left portion of meter scale.

(3) Set the AM-3349/GRC-106 TEST METER switch to PRIM. VOLT. Observe that the test meter pointer indicates within the area of the two dark green wedges (top scale) when the service selector switch is in the SSB NSK, FSK, AM or CW positions. (If above indication is abnormal, refer to table 4-2, item 3, TM 11-5820-520 -12.)

c. Final Tuning Procedure for AN/GRC-106(*)

(1) Set the RT-662/GRC MHz and kHz controls to assigned operating frequency. The frequency digits are displayed in the windows directly above the controls.

(2) Note the AM-3349/GRC-106 ANT TUNE and ANT LOAD predetermined setting on the antenna tuning and loading chart, or the LOGGING CHART.

(3) Adjust the AM-3349/GRC-106 ANT TUNE control to match the numbers on the chart used.

(4) Adjust the AM-3349/GRC-106 ANT LOAD control to match the numbers on the chart used.

CAUTION

The HV RESET switch should not stay in TUNE position for more than two minutes. If more than two minutes are required, move the AM-3349/GRC-106 HV RESET switch to OPERATE and the RT-662/GRC SERVICE SELECTOR switch to STANDBY for 5 minutes cooling. After 5 minutes cooling set the SERVICE SELECTOR switch to the previous position and the HV RESET switch to TUNE, and proceed with the tuning procedure. ANT TUNE and ANT LOAD controls will interact with each other. To center their respective meter pointers, rotate them slowly in the direction opposite to that of the indicated error ((6) (a) and (b) below). Be sure the antenna is attached for proper loading to prevent damage to the equipment while performing (5) through (12) below.

(5) Set the AM-3349/GRC-106 HV RESET switch to TUNE. Wait for a deflection on the ANT TUNE and ANT LOAD meters.

(6) Adjust the AM-3349/GRC-106 ANT LOAD control for a center scale reading on the ANT LOAD meter.

(a) Rotate control in the direction that the meter pointer is to move. Adjust the ANT TUNE control to a center scale reading on the ANT TUNE meter.

(b) Rotate control in the direction that the meter pointer is to move, keeping the ANT LOAD meter as close to center scale as possible.

(c) Tuning of the AM-3349/GRC-106 is complete when simultaneous center scale readings are obtained on the ANT TUNE and ANT LOAD meters. (If indication is abnormal, refer to table 4-2, item 6, TM 11-5820-520-12.)

(6.1) Place the HV RESET switch of the AM-3349/GRC-106 to the OPERATE position.

(6.2) Place the TEST METER function switch of the AM-3349/GRC-106 to the PRIM VOLT position.

(6.3) Place the HV RESET switch on the AM-3349/GRC-106 to the TUNE position and observe that the test meter pointer indicates within the area of the two dark green wedges (top scale) of the test meter.

(7) Set the AM-3349/GRC-106 TEST METER switch to LOW VOLT. TEST METER pointer indicates within green portion area of top scale. (If indication is abnormal, refer to table 4-2, item 4, TM 11-5820-520-12.)

(8) Set the AM-3349/GRC-106 TEST METER switch to HIGH VOLT. TEST METER pointer indicates within green portion area of top scale. (If

indication is abnormal, refer to table 4-2, item 5, TM 11-5820-12.

(9) Set the AM-3349/GRC-106 TEST METER switch to DRIVE CUR. TEST METER pointer indicates within the two dark green wedges of top scale. (If indication is abnormal, refer to table 4-2, item 7, TM 11-5820-520-12.)

(10) Set the AM-3349/GRC-106 TEST METER switch to GRID DRIVE. TEST METER pointer indicates just below (to the left of) gray portion of the bottom scale. (If indication is abnormal refer to table 4-2, item 7, TM 11-5820-520-12.)

(11) Set the AM-3349/GRC-106 TEST METER switch to PA CUR. TEST METER pointer indicates just below (to the left of) the gray portion of the bottom scale. (If indication is abnormal refer to table 4-2, item 7, TM 11-5820-520-12.)

(12) Set the AM-3349/GRC-106 TEST METER switch to POWER OUT. TEST METER pointer indicates just below (to the left of) gray area of scale. (If indication is abnormal, refer to table 4-2, item 7, TM 11-5820-520-12.)

CAUTION

The HV RESET switch should not stay in TUNE position for more than two minutes.

(13) Turn the AM-3349/GRC-106 HV RESET switch to OPERATE.

NOTE

ANT TUNE and ANT LOAD counter settings should be logged in the logging chart with a pencil after (13) above has been completed. These settings may be used for future tuning references unless ANT TUNE and ANT LOAD meter pointers indicate in the red (left or right of center scale) portion of the scale during operation. If the settings cannot be used, repeat tuning procedure (1) through (13) above.

3-11. Intercommunication Set AN/VIC-1(V) Starting Procedures.

Turn on and prepare the AN/VIC-1(V) (fig. 1-3) for intercom and AN/GRC-106(*) operation as follows:

a. Set the AM-1780/VRC POWER CKT BKR ON/OFF switch to ON and observe that the POWER indicator lights.

b. Set the AM-1780/VRC MAIN PWR switch to INT ONLY.

c. Set the AM-1780/VRC INT ACCENT ON/OFF switch to ON.

d. Set the AM-1780/VRC RADIO TRANS switch to CDR + CREW.

e. Set the AM-1780/VRC INSTALLATION SWITCH to OTHER.

f. Operate each crew box (C-2298/VRC) on interphone, to check AN/VIC-1(V) system.

3-12. Local Operation

a. Radio Teletypewriter Reception.

NOTE

MD-522(*)/GRC is provided with an automatic "mark hold." With the "AUTO MARK-HOLD" switch in the ON position, the teletypewriter will not open during the period of no signals or when signals are too weak for interchangeability.

(1) On the RT-662/GRC, set the SERVICE SELECTOR switch to SSB/NSK or FSK as required. Set the MANUAL RF GAIN control fully clockwise, and the AUDIO GAIN control at midposition.

(2) Set the MD-522(*)/GRC MODE SELECTOR switch to 850 Hz, or 85 HZ, or 85 HHz DIV, as required.

(3) Set the MD-522(*)/GRC AUDIO GAIN control for a comfortable level of audio, on the incoming tones from the distant station.

(4) Adjust MD-522(*)/GRC BFO control (on 850 Hz only) for two clean ellipses on the cathode ray tube when a signal having proper speed and shift is being received.

(5) When signal is received, set TT-98(*)/FG MOTOR ON/OFF switch to ON and/or set the TT-76(*)/GGC SELECTOR switch to position 1, as desired, to receive message on the respective teletypewriter. Adjust MD-522(*)/GRC BFO control (on 850 Hz only) slightly to eliminate errors in received copy.

b. Radio Teletypewriter Transmission.

(1) Set the MD-522(*)/GRC SEND/RCV switch on the auxiliary RCV/SEND switch (on the shelf (fig. 1-8)) to SEND.

(2) **Send a message.** In the AN/VSC-3 and AN/VSC-3 (with MK-2488), use the TT-76(*)/GGC or TT-98(*)/FG. In the AN/VSC-3A and AN/VSC-3A (with MK-2488), use the TT-76(*)/GGC or AN/UGC-74A(V)3.

NOTE

The TT-76(*)/GGC and the TT-98(*)/FG must be set up for 50 or 75 baud operation.

NOTE

To receive a home copy in the AN/VSC-3 (with MK-2488) and AN/VSC-3A (with MK-2488), the HOME COPY switch on the J-4024/U must be set to either REC 1 or REC 2.

(3) Immediately after sending message, set the auxiliary RCV/SEND switch back to RCV.

c. Voice or CW Communications.

(1) On the RT-662/GRC, set the SERVICE SELECTOR switch to SSB/NSK or CW as required. Set MANUAL RF GAIN AND AUDIO GAIN controls as cited in a (1) above.

(2) Set the MD-522(*)/GRC MODE SELECTOR to voice.

(3) Set the MD-522(*)/GRC AUDIO GAIN control for a comfortable level of audio on the incoming voice or CW signal.

(4) Set the VOICE-CW/TTY switch on the AN/VSC-3 control box to VOICE-CW. Turn the control box INVERTER switch OFF.

(5) Observe that the control box NON-SECURE VOICE indicator lamp is on.

(6) Operate the controls at the appropriate operation position in accordance with the procedures given in paragraph 3-6.

(7) When the AN/GRC-106(*) is to be operated in the CW mode, disconnect cable W21 from the control box AUDIO connector (fig. 3-1) and connect Telegraph Key KY-116/U to the connector.

(8) When the AN/GRC-106(*) is to be operated in the voice mode without the AN/VIC-1(V), connect Headset H-33/PT or Microphone M-29/U to the control box AUDIO connector.

3-13. Stopping Procedures.

a. Set power switches on the AN/VIC-1(V), MD-522(*)/GRC, TT-76(*)/GGC, and TT-98(*)/FG to OFF. Set the power switches on the J-4024/U and DLED to OFF.

b. Set the RT-662/GRC or RT-834/GRC SERVICE SELECTOR switch to STANDBY. Allow 2 minutes for the AN/GRC-106(*) to cool. Keep the HV RESET switch on the AM-3349/GRC-106 at OPERATE position when AN/GRC-106(*) is turned OFF or ON. After the 2 minute cooling period set the AM-3349/GRC-106 PRIM. PWR switch and the RT-662/GRC or RT-834/GRC SERVICE SELECTOR switch at OFF.

c. Set the INVERTER and MAIN circuit breakers on the AN/VSC-3 control box (fig. 3-1) to OFF.

d. Perform the stopping procedures to shut down.

the M577A1 engine or auxiliary power unit (TM 9-2300-224-10/3/2).

d. Place dust covers over the TT-76(*)/GGC and TT-98(*)/FG.

e. Set the MX-7778/GRC CIRCUIT BREAKER switch to OFF.

3-14. Remote Operation

(fig. 3-4)

The materials and equipment required for remote operation are given in paragraph 1-9. Before attempting any mode of remote operation, setup the radio set for the applicable mode of local operation (para 3-8 through 3-12), and then place the RT-662/GRC SERVICE SELECTOR switch at STANDBY.

WARNING

Be sure that the remote control box SEND-RCV switch is preset at RCV.

a. *Remote CW SSB Voice, or Compatible Am Voice.*

(1) Remove local Control C-434/GRC from Bag CW-189/GR (p/o AN/GRA-6).

(2) Disconnect cable W-21 from the control box and connect P1 of the C-GRC to the control box AUDIO connector.

(3) Slide the C-434/GRC into its brackets on the shelf (fig. 1-8) and secure the unit with the tab.

(4) Connect field wire from the C-GRC, LINE L1 and LINE L2 connectors to the GRA-6 binding posts inside the vehicle (fig. 3-5). Connect handset to AUDIO connector on the C-434/GRC.

(5) Connect skinned ends of a roll of field wire to the GRA-6 binding posts outside the vehicle (fig. 3-6). Figure 3-6 shows binding posts with the cover removed.

(6) If remote cw operation is required, connect

the skinned ends of the second roll of field wire to the REM CW binding posts outside the vehicle. Tag the roll of wire.

(7) Transport Remote Control C-433/GRC, and Handset H-33/PT(*) (p/o NA/GRA-6) Headset and Telegraph key (p/o AN/GRC-106(*)) for cw operation and string the field wire pair or pairs to the remote site.

(8) Cut, skin, and connect the *untagged* field wire pair to LINE L1 and LINE L2 of the C-433/GRC.

(9) Connect the H-33/PT to the C-433/GRC AUDIO connector and turn the C-433/GRC SELECTOR switch to TEL.

(10) Ring for the operator at the vehicle and instruct him to operate the following switches: the modem MODE SELECTOR switch to VOICE; the 106 rt SERVICE SELECTOR switch to SSB NSK for single-sideband voice, to AM for compatible AM voice or to cw for cw operation; the C-434/GRC REMOTE switch to SET 1; and the control box VOICE-CW/TTY switch to VOICE-CW. (Control box LOCAL/REMOTE switch is not involved in remote voice or CW operation. Leave this switch in the LOCAL position.)

(11) Turn the C-433/GRC SELECTOR switch fully counterclockwise and depress the remote H-33/PT push-to-talk button. If the operator at the vehicle indicates that the radio set did not key, release push-to-talk button and interchange the field wire pair connections to LINE L1 and LINE L2 of the C-433/GRC.

(12) Depress the H-33/PT push-to-talk button and speak into the microphone to transmit. Release the H-33/PT push-to-talk button to receive.

(13) For cw operation, connect the tagged field wire pair to the telegraph key and operate it to transmit. Connect H-227/U Headset (P/O AN/GRC-106(*)) to C-433/GRC AUDIO receptacle for cw reception.

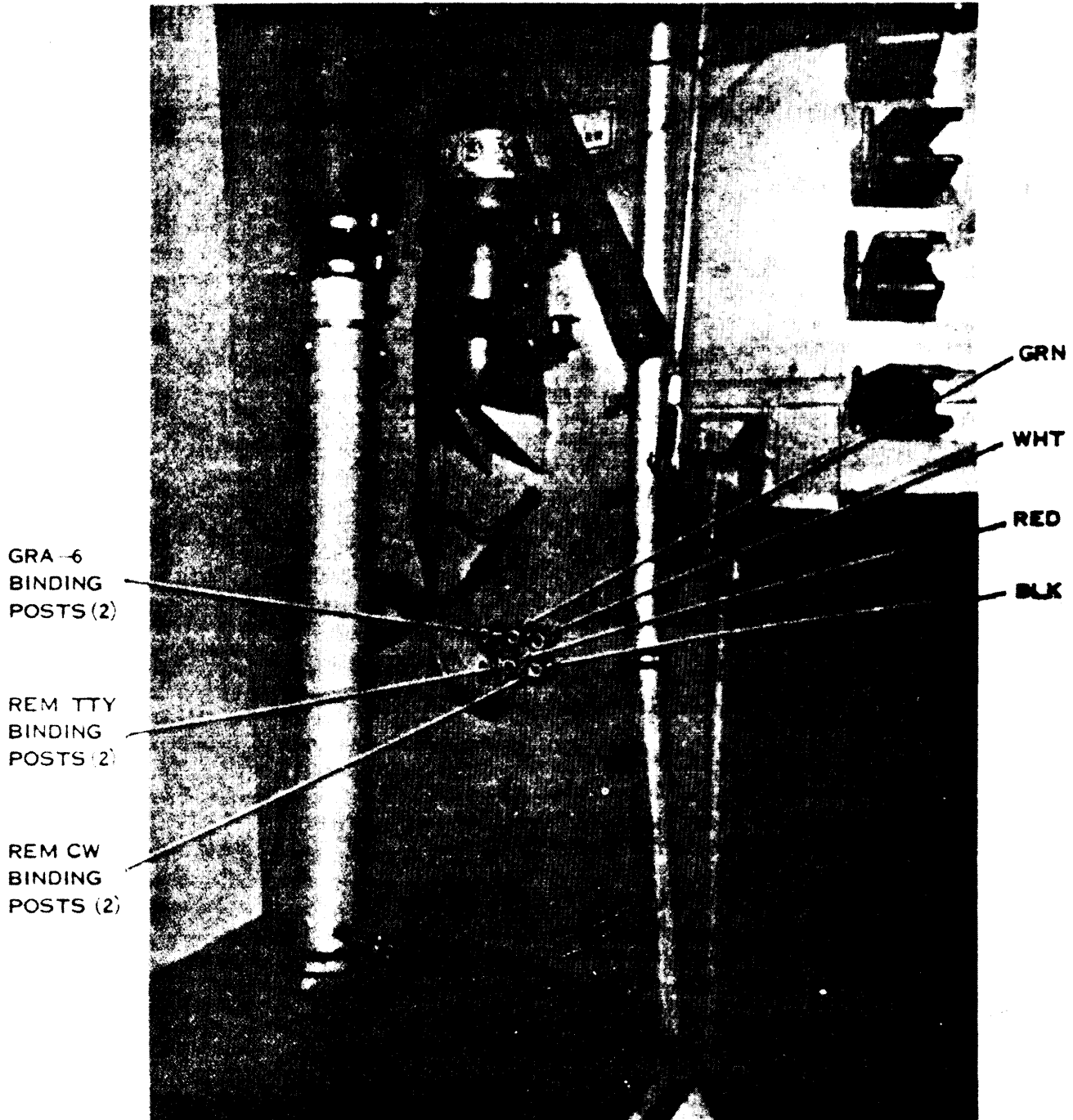

EL 5815-332-15-TM-17

Figure 3-5. Remote binding posts on curbside of rear wall.

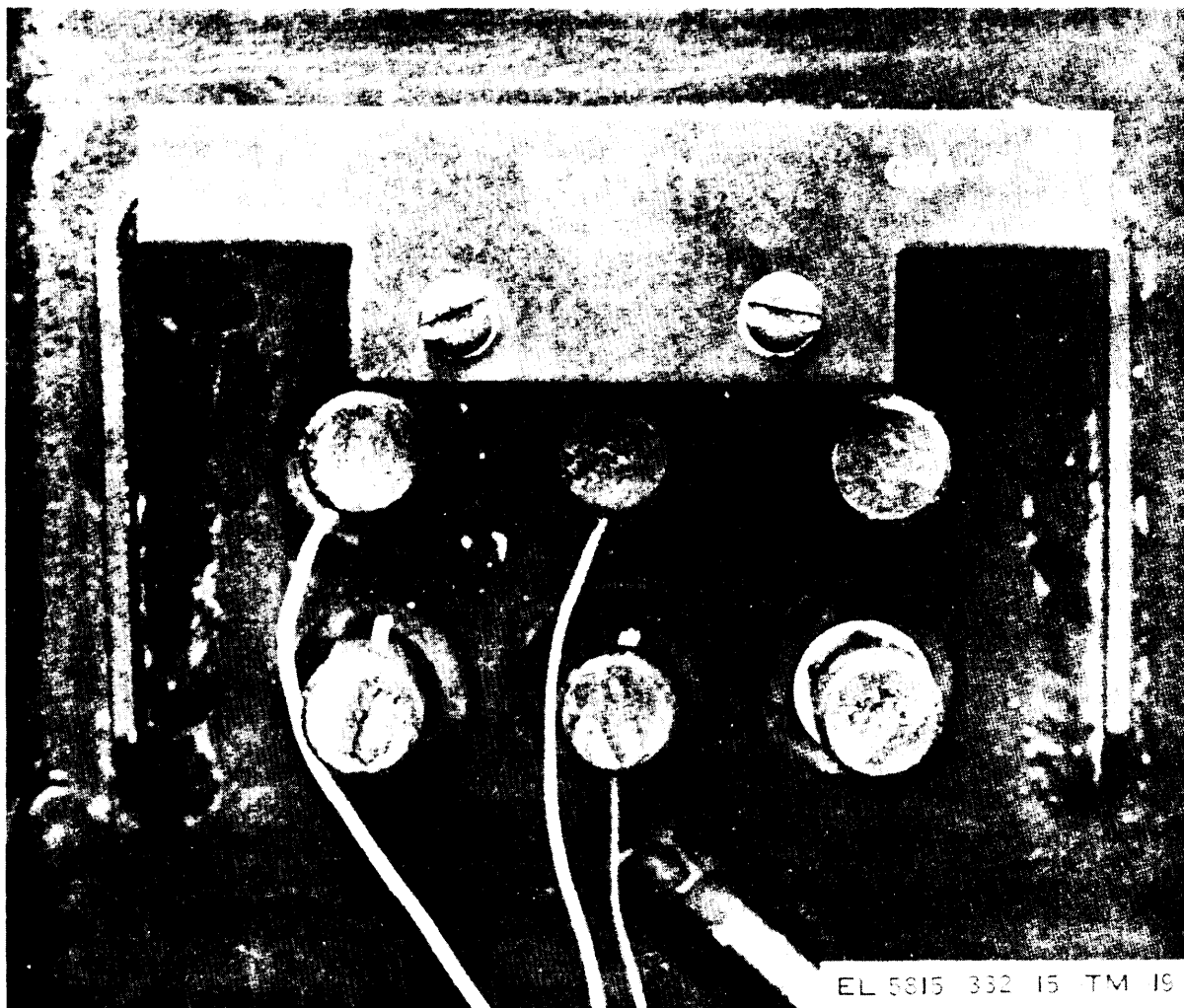

Figure 3-6. Exterior binding posts with cover removed.

b. Remote Teletypewriter Operation (850 Hz, 85 Hz, or 85 Hz Diversity Shift).

NOTE

Teletypewriter TT-4C/TG (used below) may be replaced with a similar teletypewriter set.

(1) Connect a field wire pair to the REM TTY binding posts outside the vehicle (fig. 3-6). Tag the field wire roll for identification.

(2) Perform the procedure given in a (1) through (11) above. While performing (7) above, also transport the Remote Control Box, TT -

4C/TG, A.C. power source for TT-4C/TG, and string the tagged field wire roll to the remote site.

(3) Plug the TT-4C/TG red and black plugs into the TTY jacks of the remote control box, for nonsecure RTTY operation. For *secure* RTTY operation, use special cables provided with security equipment and binding post assembly (fig. 1-10) on TT-4C/TG binding post terminal strip. Plug TT 4C/TG ac power cord into 115 volt 50-60 Hz power source at the remote site.

(4) Cut, skin, and connect the tagged field wire pair ((1) above) to the remote control box TTY binding posts (fig. 3-2).

(5) Set TT-4C/TG for operation on 20 MA loop current (consult TM 11-5815-206-12).

WARNING

During the operation, an 80-volt dc difference in potential exists between the wires of the field wire pair. Be careful!

(6) Using the AN/GRA-6, instruct the operator at the vehicle to turn the control box VOICE-CW/TTY switch to TTY; the MD-522(*)/GRC MODEM SELECTOR switch to 850 Hz, 85 Hz, or 85 Hz DIV as required, and the RT-662/GRC SERVICE SELECTOR switch to FSK for 850 Hz shift or to SSB NSK for 85 Hz or 85 Hz diversity shift.

(7) Instruct the operator at the vehicle to set the control box LOCAL-REMOTE switch to REMOTE.

(8) Set TT-4C/TG MOTOR switch to ON.

(9) If the TT-4C/TG control panel meter indicates to the left of zero, instruct the operator at the vehicle to set the control box LOCAL-REMOTE switch to LOCAL, interchange the field wire pair connections to the remote control box TTY binding posts, then repeat (7) above.

(10) Turn the TT-4C/TG LINE INCR EASE control to full clockwise position (minimum resistance). The TT-4C/TG control panel meter should read 20 milliamperes.

NOTE

If the indication given in (9) above cannot be obtained, check the field wire connections (fig. 3-4).

(11) To transmit, set the remote control box SEND-RCV switch to SEND and operate the TT-4C/TG keyboard. To receive, set the remote control box SEND-RCV switch to RCV, immediately after sending message, set the remote control box SEND-RCV switch to RCV.

c. *Pony Circuit Operation.* For a tty and telephone order wire circuit over land lines (pony circuit) without any radio teletype transmission or reception, perform the procedures given in (1), (2), and (3) below.

(1) Perform the procedures given in a and b above.

(2) Instruct the operator at the vehicle to set the MD-522A/ GRC MODE SELECTOR switch to VOICE and the RT-662/GRC SERVICE SELECTOR switch to STANDBY.

(3) Leave the remote box SEND-RCV switch to RCV, during Pony circuit operation.

d. *Remote Stopping Procedure.* After per-

forming the procedures in (1) and (2) below, instruct the operator at the vehicle to place the radio set, as required, in a standby or completely shut-down condition.

(1) Set the remote control box SEND-RCV switch to RCV.

(2) Set the TT-4C/TG MOTOR switch to OFF.

3-15. Teletypewriter Operation under Unusual Conditions

CAUTION

The TT-76(*)/GGC and TT-98(*)/FG teletypewriters are not designed to be operated in blowing sand or heavy dust. To prevent damage to the teletypewriters, it is mandatory that the dust covers be properly installed over the teletypewriters (fig. 1-8) when these conditions prevail *or whenever the M577A1 is in motion.* Make sure the skirt of the TT-98(*)/FG and TT-76(*)/GGC dust covers fit into the groove around the bottom of the base plate on each machine.

Operation of the teletypewriters in blowing sand, heavy dust, or when the M577A1 is in motion is limited to the following:

a. The TT-98(*)/FG will only be used for radio teletypewriter reception.

b. The TT-76(*)/GGC will be used only for radio teletypewriter reception and for radio teletypewriter transmission using a prepunched tape when the prepunched tape has previously been installed in the transmitter-distributor of the TT-76(*)/GGC. The transmitter distributor of the TT-76(*)/GGC can be started or stopped, with the dust cover in place, by pressing against the fabric cover and manipulation of the FEED RETRACT actuating lever.

3-16. Recognition and Identification of Jamming

It is likely that under real or simulated tactical conditions the receiver will be jammed by the enemy. Enemy jamming is easily done by transmitting a strong signal on the same frequency, thereby making it difficult or impossible to hear the desired signal. Unusual noises or strong interference heard on the receiver may be enemy jamming, signals from a friendly station, noise from a local source, or the receiver may be defective. To determine whether or not the interference is originating in the receiver, disconnect the antenna, remove the antenna, or short the ANT post to the chassis. If the interference *continues*; the receiver

is defective. Enemy jamming signals may be typed as *continuous wave* or *modulated*. A jamming signal may be intended to block a single frequency. This is called *spot* jamming. The enemy may use one of several transmitters to jam a block or band of frequencies.

a. Continuous-Wave Jamming. Cw jamming is transmitted as a steady carrier. This signal beats with other signal and produces a steady tone in the headset. Cw jamming signals may also be keyed by using a random on and off signal or using actual code characters keyed at the same rate or a little faster than the signal being received.

b. Modulated Jamming. Modulated jamming signals may consist of noise, laughter, singing, music, various tones, or most any unusual sound, or it may be a combination of these sounds. Various types of modulated jamming signals are explained below.

(1) *Spark.* This is one of the simplest, most effective, and most easily produced jamming signals. This type of signal sounds very rough, raspy, and sometimes like an electric motor with sparking brushes running. This type of signal is very broad; therefore, it will interfere with a large number of communication channels.

(2) *Sweep-through.* This signal is the result of sweeping or moving a carrier back and forth across your frequency at a slow or rapid rate. The numerous signals of varying amplitude and frequency produce a sound like that of a low-flying airplane passing overhead. This type of jamming is effective over a broad range of frequencies. When it is varied rapidly, it is effective against all types of voice signals.

(3) *Stepped tones or bagpipes.* This signal usually consists of several separate tones. The tones are transmitted in the order of first increasing and then decreasing pitch, repeated over and over. The audible effect is like the sound of a Scottish bagpipe.

(4) *Noise.* Noise is random both in amplitude and frequency. It is considered one of the better types of jamming modulation. It produces a sound similar to that heard when a receiver is not tuned to a station and the volume or gain control is turned to maximum.

(5) *Cuffs.* The signal consists of a quick rise and slow fall of a variable audiofrequency. The sound is similar to the cry of the sea gulls.

(6) *Tone.* This signal consists of a single audiofrequency of unvarying tone. It produces a steady howl in the headset. Another use of tone is to vary it slowly. It produces a howling sound of varying pitch.

3-17. Antijamming

When it is known that a receiver is being jammed, the operator will notify the immediate superior officer and continue to operate the equipment. To provide maximum intelligibility of jammed signals, follow the operational procedure:

a. Operate the AN/GRC-106(*) as outlined in TM 11-5820-520-12.

b. Detune the RT-662/GRC **FREQ** **VERNIER** knob several degrees on either side of the desired signal in voice or 850 Hz RTTY modes. This may cause some separation of the desired signal and the jamming signal. Use of RT-834/GRC **Frequency Vernier** in (MD-522A/GRC) 85 Hz or 85 Hz **DIVERSITY** will cause errors in received copy.

c. Vary the RT-662/GRC **RF GAIN** control. This may reduce the jamming signal enough to permit the weaker wanted signal to be heard.

d. Vary the MD-522A/GRC **AUDIO GAIN** control. The level of the desired signal may be raised enough to be heard.

e. If the above procedures do not provide sufficient signal separation for operation, change to the alternate frequency and alternate call sign.

3-18. Preparation for Vehicle Movement

Before the M577A1 vehicle is moved perform the following:

a. Disconnect any remote equipment wires from the binding posts outside the vehicle (fig. 3-6).

b. If Antenna Group AN/GRA-50 is installed, dismantle it and place in its bag. Store the antenna storage bag below the roadside table at the front of the vehicle (fig. 1-1).

c. Securely fit the dust covers (fig. 1-8) over the security equipment and the TT-76(*)/GGC and the TT-98(*)/FG. Before installing the TT-98(*)/FG dust cover, remove the handcrank from the set. Replace the handcrank through the hole in the dust cover after the cover is installed.

d. Secure the AN/GRC-106(*) whip antenna bag with straps below the roadside table.

WARNING

DO NOT move the vehicle with the AN/GRC-106 whip antenna installed unless it is tied down.

e. If the AN/GRC-106(*) whip antenna is to remain installed, tie it to the rear of the vehicle as follows:

(1) Pull the loose ends of the antenna tiedown ropes to the rear of the vehicle until the top of the antenna is 8 or 9 feet from the ground.

TM 11-5815-332-15

(2) Tie the tiedown ropes to a convenient point on the rear of the vehicle (tiedown ropes must be kept clear of the rear door).

f. Secure the chair to the curbside table with the canvas strap (fig. 1-6).

g. Place the remote control box and other loose items in the storage box (fig. 1-6) and secure the door.

h. Inspect all equipment and cables in the vehicle to insure that they are securely mounted.

CHAPTER 4
OPERATOR'S MAINTENANCE INSTRUCTIONS

PREVENTIVE MAINTENANCE CHECKS AND SERVICES (PMCS)
AND SYSTEM READINESS CRITERIA

4-1. GENERAL .

a. Maintenance Forms and Records. The forms and records you fill out have several uses, including: (1) a permanent record of the services, repairs, and modifications made on your equipment; (2) reports to the next level of maintenance and to your commander; and (3) a checklist for you when you want to know the status of the equipment after its last use, and whether faults, if any, have been fixed. For information on forms and records, see DA PAM 738-750 (if USMC, see TM-4700-15/1d).

b. Routine Checks. Routine checks, such as cleaning, dusting, washing, stowing items not in use, covering unused receptacles, -and checking for damage, are not listed as PMCS checks. They are things you should do any time you see they must be done. Ensure that all discrepancies are noted and corrected.

c. PMCS. Operator's PMCS are the required periodic inspections and actions necessary to keep your equipment in good operating condition.

d. System Readiness Criteria. System Readiness Criteria are those standard, specific requirements your system must meet for it to be mission-capable.

4-2. PMCS table (table 4-1). The PMCS table lists all the scheduled maintenance tasks required for your system.

a. Explanation of Columns.

(1) Item No. This column contains a number for each procedure to be performed. When reporting malfunctions or failures on DA Form 2404, Equipment Inspection and Maintenance Worksheet, place this number in the "TM Item No." column.

(2) Interval. These columns tell you when to do a procedure. Each column that applies will contain an asterisk (*) . Some procedures will have asterisks in more than one column.

(3) Item to be inspected/procedure. This column contains the name of the item to be inspected and tells how to perform the required checks and services on it. Carefully follow these instructions and perform them in the order listed.

4-2. PMCS table (cont).

(4) Equipment is not ready\available if:. This column tells you the conditions which will cause the equipment to be classified as not ready (red) for readiness reporting.

NOTE

If the equipment must be kept in continuous operation, check and service only those items that can be checked and serviced without disturbing operation. Make the complete checks and services when the equipment can be shut down.

b. Instructions.

(1) Do your before (B) preventive maintenance just before you operate your equipment. Pay attention to CAUTIONS and WARNINGS.

(2) Do your during (D) preventive maintenance while the equipment and/or its component systems are in operation.

(3) Do your after (A) preventive maintenance right after operating the equipment. Pay attention to the CAUTIONS and WARNINGS.

(4) Do your weekly (W) preventive maintenance once a week.

(5) Do your monthly (M) preventive maintenance once a month.

(6) If something doesn't work, troubleshoot it with the instructions in this manual and notify your supervisor.

(7) Always do your preventive maintenance in the same order.

(8) If anything goes wrong and you can't fix it, write it on your DA Form 2404, or applicable form. If you find something seriously wrong, report it to the next level of maintenance IMMEDIATELY.

WARNINGS

Never operate the equipment until it has been properly grounded. Electrical defects in the load lines or equipment can cause DEATH by electrocution when contact is made with an ungrounded system.

Adequate ventilation should be provided while using TRICHLOROTRIFLUOROETHANE. Prolonged breathing of vapor should be avoided. The solvent should not be used near heat or open flame, the products of decomposition are toxic and irritating. Since TRICHLOROTRIFLUOROETHANE dissolves natural oils, prolonged contact with skin should be avoided. When necessary use gloves which the solvent cannot penetrate. If the solvent is taken internally, consult a physician.

Compressed air shall not be used for cleaning purposes except where reduced to less than 29 psi and then only with effective chip guarding and personnel protective equipment. Do not use compressed air to dry parts when TRICHLOROTRIFLUOROETHANE has been used. Compressed air is dangerous and can cause serious bodily harm if protective means or methods are not observed to prevent chip or particle (of whatever size) from being blown into the eyes or unbroken skin of the operator or other personnel.

Table 4-1. Operator's Preventive Maintenance Checks and Services

Item No.	Interval					Item to be inspected Procedure	Equipment is not ready/available if:
	B	D	A	W	M		
1						Carrier, Command Post, Light M577A1 Follow PMCS procedures in TM 9-2350-257-10.	Carrier is inoperable and no substitute is available.

4-3 System Readiness Criteria table (tables 4-2 and 4-2.1). The System Readiness Criteria table is your "checklist" for determining the mission readiness of your system.

a. Explanation of Columns.

(1) Item No. This column contains a number for each readiness-reportable item. When reporting, on DA Form 2404, Equipment Inspection and Maintenance Worksheet, malfunctions or failures that cannot be repaired "on-the-spot," place this number in the "TM Item No." column.

(2) Subsystems and Components. This column lists all system equipments which are required for readiness reporting.

(3) Equip Model ID #. This column contains the equipment model identification number (type-classification) of each equipment.

(4) Qty. This column tells you the quantity of equipment/items furnished as part of, or with, your system.

(5) Remarks. This column contains other information/special instructions and will alert you to any exceptions to the requirements, designed to give you maximum mission flexibility.

b. Instructions. Perform the following steps to determine system readiness:

(1) Before starting your mission, ensure that listed equipments/items are on hand and operational. If necessary, perform operational checks in applicable TM's to determine the condition of your equipment.

(2) Take note of REMARKS column. This column contains exceptions and special instructions to help you tailor your requirements to your mission.

(3) If any required equipment/item is not on hand and operational, your entire system is deadlined (unless otherwise noted in the REMARKS column).

(4) Correct any discrepancies, then re-check all equipments/items on list. When all required equipment/items are on hand and operational, your system is mission-ready.

(5) After completing your mission, and before moving to a new location, ensure that all listed equipments/items are on hand.

Table 4-2. SYSTEM READINESS CRITERIA

System ratings: Fully Mission Capable (FMC)
Not Mission Capable (NMC)

Item No.	AN/VSC-3 Subsystems and Components	Equip Model ID #	Quantity	REMARKS
1R	Radio Set (including):	AN/GRC-106	1	
2R	Receiver-Transmitter	RT-662/GRC	1	
3R	Amplifier, RF	AM-3349/GRC-106	1	
4R	Handset	H-33/PT	1	System may be rated FMC if H-33/PT is rated NMC provided H-227/U is rated FMC.
5R	Headset	H-227/U	1	System may be rated FMC if H-227/U is rated NMC provided H-33/PT and M-29B/U are rated FMC.
6R	Microphone OR	M-29B/U	1	System may be rated FMC if M-29B/U is rated NMC.
7R	Radio Set (including):	AN/GRC-106A	1	
8R	Receiver-Transmitter	RT-834/GRC	1	
9R	Amplifier, RF	AM-3349/GRC-106	1	
10R	Handset	H-33/PT	1	System may be rated FMC if H-33/PT is rated NMC provided H-227/U is rated FMC.
11R	Headset	H-227/U	1	System may be rated FMC if H-227/U is rated NMC provided H-33/PT and M-29B/U are rated FMC.

Table 4-2. SYSTEM READINESS CRITERIA (cont'd)

System ratings: Fully Mission Capable (FMC)
Not Mission Capable (NMC)

Item No.	AN/VSC-3 Subsystems and Components	Equip Model ID #	Qty	REMARKS
12R	Modem, Radio Teletype-writer	MD-522A/GRC	1	
13R	Suppressor, Electrical Transient	MX-7778/GRC	1	
14R	Teletypewriter Set	TT-98/FG	1	
15R	Reperforator-Transmitter	TT-76/GGC	1	
16R	Low Level Signalling Device	TT-523/GGC	1	
17R	Dynamic Loudspeaker	LS-166/U	1	
18R	Motor Generator, Inverter	PU-724/G	1	
19R	Antenna Group (consisting of):	AN/GRA-50	1	System may be rated FMC if AN/GRA-50 is rated NMC and whip antenna is rated FMC.
20R	Cable Assembly	CG-687/U	1	
21R	Halyard	MX-2706/G	2	
22R	Insulator	IL-4/GRA-4	1	
23R	Reeling Machine		2	
24R	Wire Assembly	CX-7303/G	2	
25R	Measuring Tape		1	
26R	Bag, Carrying	BG-175	1	

Table 4-2. SYSTEM READINESS CRITERIA (cont'd)

System ratings: Fully Mission Capable (FMC)
 Not Mission Capable (NMC)

Item No.	AN/VSC-3 Subsystems and Components	Equip Model ID #	Qty	REMARKS	
27R	Whip Antenna (consisting of):		1	System may be rated FMC if Whip Antenna is rated NMC provided AN/GRA-50 is rated FMC.	
28R	Mast Base	AB-652	1		
29R	Mast Section	MS-116A	3		
30R	Mast Section	MS-117A	1		
31R	Mast Section	MS-118A	1		
32R	Antenna Tip Assembly		1		
33R	Antenna Cover		1		
34R	Adapter, Connector	UG-201A	1		
35R	Adapter, Connector	UG-306B	1		
36R	Bag, Carrying	CW-206	1		
37R	Communications Security Equipment	KW-7	1		
38R	Carrier, Command Post Light	M577A1	1		System may be rated FMC if appropriate substitute is available.

Table 4-2.1. SYSTEM READINESS CRITERIA

System ratings: Fully Mission Capable (F M C)

Item No.	AN/VSC-3A Subsystems and Components	Equip Model ID #	Qty	REMARKS
1R	Radio Set (including):	AN/GRC-106	1	
2R	Receiver-Transmitter	RT-662/GRC	1	
3R	Amplifier, RF	AM-3349/GRC-106	1	
4R	Handset	H-33/PT	1	System may be rated FMC if H-33/PT is rated NMC provided H-227/U is rated FMC.
5R	Headset	H-227/U	1	System may be rated FMC if H-227/U is rated NMC provided H-33/PT and M-29B/U are rated FMC.
6R	Microphone OR	M-29B/U	1	System may be rated FMC if M-29B/U is rated NMC.
7R	Radio Set (including):	AN/GRC-106A	1	
8R	Receiver-Transmitter	RT-834/GRC	1	
9R	Amplifier, RF	AM-3349/GRC-106	1	
10R	Handset	H-33/PT	1	System may be rated FMC if H-33/PT is rated NMC provided H-227/U is rated FMC.
11R	Headset	H-227/U	1	System may be rated FMC if H-227/U is rated NMC provided H-33/PT and M-29B/U are rated FMC.

Table 4-2.1. SYSTEM READINESS CRITERIA (cont'd)

System ratings: Fully Mission Capable (FMC)
Not Mission Capable (NMC)

Item No.	AN/VSC-3A Subsystems and Components	Equip Model ID #	Q t y	REMARKS
12R	Modem, Radio Teletype-writer	MD-522A/GRC	1	
13R	Suppressor, Electrical Transient	MX-7778/GRC	1	
14R	Terminal, Communications	AN/UGC-74A(V)3	1	
15R	Reperforator-Transmitter	TT-76/GGC	1	
16R	Low Level Signalling Device	TT-523/GGC	1	
17R	Dynamic Loudspeaker	LS-166/U	1	
18R	Motor Generator, Inverter	PU-724/G	1	
19R	Antenna Group (consisting of):	AN/GRA-50	1	System may be rated FMC if AN/GRA-50 is rated NMC and whip antenna is rated FMC.
20R	Cable Assembly	CG-687/U	1	
21R	Halyard	MX-2706/G	2	
22R	Insulator	IL-4/GRA-4	1	
23R	Reeling Machine		2	
24R	Wire Assembly	CX-7303/G	2	
25R	Measuring Tape		1	
26R	Bag, Carrying	BG-175	1	

Table 4-2.1. SYSTEM READINESS CRITERIA (cont'd)

System ratings: Fully Mission Capable (FMC)
Not Mission Capable (NMC)

Item No.	AN/VSC-3A Subsystems and Components	Equip Model ID #	Quantity	REMARKS
27R	Whip Antenna (consisting of):		1	System may be rated FMC if Whip Antenna is rated NMC provided AN/GRA-50 is rated FMC.
28R	Mast Base	AB-652	1	
29R	Mast Section	MS-116A	3	
30R	Mast Section	MS-117A	1	
31R	Mast Section	MS-118A	1	
32R	Antenna Tip Assembly		1	
33R	Antenna Cover		1	
34R	Adapter, Connector	UG-201A	1	
35R	Adapter, Connector	UG-306B	1	
36R	Mast Assembly	AB-155	3	
37R	Carrier, Command Post Light	M577A1	1	System may be rated FMC if appropriate substitute is available.

CHAPTER 5

ORGANIZATIONAL MAINTENANCE INSTRUCTIONS

Section I. ORGANIZATIONAL PREVENTIVE MAINTENANCE CHECKS AND SERVICES

5-1. Scope of Organization Maintenance

This chapter contains instructions covering organizational maintenance of the AN/VSC-3. It includes, instructions for performing preventive and periodic maintenance services and repair functions to be accomplished by the organizational repair technician.

b. Organizational maintenance of the AN/VSC-3 includes:

- (1) Monthly maintenance (para 5-2).
- (2) Organizational monthly preventive maintenance checks and services (table 5-1).
- (3) Organizational troubleshooting procedure (para 5-4).
- (4) Removal and replacement of damaged antenna mast sections (para 5-5).

5-2. Tools and Test Equipment and Material Required

- a. Multimeter AN/URM-105.
- b. Tool Kit, Electronic Equipment TK-101/G.

c. Silicone Compound, NSN 6850-00-880-7616.

NOTE

If either component of Radio Set AN/GRC-106(*) requires repair, turn in both the RT-662/GRC or RT-834/GRC, and AM-3349/GRC-106.

5-3. Monthly Maintenance

Maintenance of the AN/VSC-3 will be scheduled in accordance with the requirements given in DA Pam 738-750. All deficiencies or shortcomings will be recorded, and those not corrected during the checks and services will be immediately reported to higher category maintenance by use of forms and procedures specified in DA Pam 738-750. The daily checks and services (table 4-1) constitute a part of the monthly preventive maintenance checks and services, and must be performed concurrently. Perform all the checks and services listed in the monthly preventive maintenance checks and services (table 5-2) in the sequence listed.

Table 6.1. Organizational Preventive Maintenance Checks and Services Monthly Schedule

Item No.	Item to be inspected	Procedures Check for and have repaired, replaced, or adjusted as necessary	For readiness reporting equipment is not ready/available if:
1	Mast Base AB-652/GR	<p style="text-align: center;">WARNING</p> <p>Before checking Mast Base AB-652/GR for moisture, rust, and corrosion, make sure your equipment is turned off.</p> <p>Check interior and exterior for rust and corrosion. Disassemble the AB-652/GR (using suitable crescent wrench) to check for the entry of water. If necessary replace washer, NSN 5310-00-189-8907, and the electrical cap, NSN 5999-00-264-9213. Clean the interior then reassemble and check exterior for cleanliness and corrosion. Clean as necessary using a wire brush and trichloroethane. Coat exterior corrodible parts with a light film of Silicone compound, NSN 6850-00-880-7616 (cap is used to cover antenna support when mast sections are removed).</p>	<p>Washer is defective. Exterior is corroded.</p>
2	Installation	<p>Check to see that the equipment is properly installed.</p>	
3	Deleted	<p>Check to see that cables are connected correctly.</p>	

Table 5-1. Organizational Preventive Maintenance Checks and Services Monthly Schedule - Continued.

Item No.	Item to be inspected	Procedure Check for and have repaired replace, or adjusted necessary	For readiness reporting equipment is not ready/available if:
4	Preservation	Check all surfaces of components for evidence of fungus. Remove rust and corrosion from metal surfaces by lightly sanding with fine sandpaper. Brush two thin coats of the proper paint on the bare metal to protect it from further rust or corrosion. Refer to TM 43-0118.	
5	Binding posts	Check to see the REM, CW, REM TTY, and GRA-6 binding posts, inside and outside the vehicle are clean and that secure contact is made with attached wires. NOTE <u>If your equipment fails to operate,</u> troubleshoot with proper equipment. Report any deficiencies using the proper forms; see DA Pam 738-750.	
6 7	Completeness Mountings	Check to see that the equipment is complete. Check all equipment mountings; that they are fastened securely. Check for loose and missing hardware	Auxiliary power unit will not start.
8	Auxiliary power unit	Perform the preliminary operating procedures (para 3-8). Then start the auxiliary power unit to verify that it will start, and that it does supply power to the AN/VSC-3 equipment (TM 9-2300 -224-10/3/2). To stop the auxiliary power unit first perform the procedures in paragraph 3- 13a and b.	
9	Cleanliness	Check to see that equipment is clean; check working area for cleanliness (shelves, walls, and floor).	
10	Lights(or lamps)	Check to see that all lights (or lamps) can be turned on and that there are no burned out bulbs.	
11	Meter faces(glass)	Check to see that the meter faces are not loose or broken.	Loose ground straps.
12	Ground straps	Check to see that ground straps LO all equipment requiring round straps are securely connected.	
13	Intercabling and connectors	Remove dirt, grease, and moisture from cable insulation and connectors. Tighten all locking rings to their connectors.	
14	Technical manuals (TM's)	Check to see that the TM's are complete and current (see app A).	
15	Fire Extinguisher	Check for broken wire seal or trigger. If extinguisher has been used, request recharge by appropriate personnel.	
16	operational check	Refer to table 4-1 and perform steps 2 through 4.	
17 ^a	Interconnecting Box J-4024A-U	Perform organizational check as described in TM11-5815-616-13.	
18 ^a	Dedicated Loop Encryption Device, TSEC/KG-84A.	Perform organizational check as described in TM 11-5810-309-23.	

^aApplies to AN/VSC-3 (WITH DLED) and AN/VSC-3A (WITH DLED) only.

Section II ORGANIZATIONAL TROUBLESHOOTING AND ANTENNA MAST SECTIONS REPLACEMENT

5-4. Organizational Troubleshooting Procedure

a. General. The organizational troubleshooting chart is a procedure for systematically checking performance of the equipment peculiar to the

AN/VSC-3. For troubleshooting the standard components of the communications system (AN-GRC - 106(*) MD-552(*)/GRC, TT-76(*)/GGC, TT-523(*)/GGC, and TT-98(*)/FG) refer to the applicable maintenance manual (app A). All corrective measures that the

organizational repairperson can perform are given in the "Corrective Measure" or "Reference" columns. If these measures do not correct the fault, higher category maintenance is required.

b. *Use of Organizational Troubleshooting Chart.* When using the organizational troubleshooting chart (c below), start at the beginning and follow each step in order if the trouble symptom is not

known. If the trouble symptom is known, proceed directly to the appropriate trouble symptom. When the trouble is a defective cable assembly, refer to cording diagram (fig. 2-1) for detailed information. If the trouble cannot be located using the chart, the trouble is probably in the standard equipment (a above); refer to the troubleshooting procedures in the appropriate manual (app A).

c. *Organizational Troubleshooting Chart.*

Item No.	Malfunction	Probable cause	Corrective action
1	AN/VSC-3 CONTROL BOX 27.5 VDC indicator does not light and dc voltmeter does not indicate with MAIN circuit breakers ON.	a. Cable W20 defective or not connected to M577A1 power source. b. Defective circuit breakers.	a. Check cable connections and continuity. Replace if defective. b. Have circuit breakers checked by higher level maintenance, to determine if replacement is necessary.
2	27.5 VDC indicator does not light, or dc voltmeter does not indicate with MAIN circuit breakers ON.	Defective indicator or voltmeter. a. Cable W14 defective or not properly connected.	Replace indicator lamp or have meter, if defective, replaced by higher level maintenance. z. Check cable connections and continuity. Replace if defective.
3	Inverter does not operate with INVERTER circuit breaker on.	b. Defective circuit breaker.	b. Have circuit breakers checked by higher level maintenance, to determine if replacement is necessary.
4	MX-7778/GRC With circuit breakers ON, power is not applied to the AN/GRC-106(*) (AM-3349/GRC and RT-662/GRC) and MD-522(*)/GRC.	a. Cable W13 defective, or improperly connected. b. Defective MX-778/GRC.	m. Check cable connections and continuity. Replace if defective. b. Have higher level maintenance troubleshoot.
5	With circuit breakers ON, power is not applied to AM-3349/GRC, RT-662/GRC, or MD-522(*)/GRC.	a. Cable W10 (AM-3349/GRC), W12, (RT-662/GRC), or W4, (MD-552(*)/M2RC) defective or improperly connected. b. Defective MX-778/GRC.	a. Check connection and continuity of appropriate cable. Replace if defective. b. Have higher level maintenance troubleshoot MX-7778/GRC.
6	AUXILIARY RCV-SEND SWITCH With switch set at SEND, message cannot be sent from TT-76*)/GGC or TT-98*)/FG. Operation is normal with SEND/RCV switch on MD-522(*)/GRC set at SEND.	Defective switch, or defective wiring to switch.	Check continuity of switch and wiring. Have higher level maintenance replace switch or wiring as required.

d. *Additional Organizational Troubleshooting Procedures.* If organizational repair personnel have not corrected a faulty AN/VSC-3 by performing the items in the troubleshooting chart (c above) and the fault is believed to be in the DC loop circuit, the following procedures should be performed. The procedures in e below are *not* authorized for use by operator/crew personnel, and may be used only on the MD-522A/GRC. Refer to figure FO-2.

NOTE

Before replacing a faulty cable assembly, check for bent pins and from pin to pin for continuity. Repair if possible.

Appropriate dummy plugs cited in Test function column steps e8, 9, 10,12, and 13 below, are to be provided by individual organizations. As an alternative, pins B

and C, or the appropriate receptacle, may be shorted together.

(1) Should the teletypewriter run open, or if the MD-522A/GRC test meter does not deflect with the METER FUNCTION switch in the DC LOOP NO. 1 position, do the following:

(a) Turn AN/GRC106(*) off.

(b) Turn teletypewriters off.

(c) Set MD-522A/GRC ON-OFF switch to ON, and METER FUNCTION switch to DC LOOP NO. 1.

(d) Set control box LOCAL/REMOTE switch to LOCAL, and BLACK/RED switch to BLACK.

WARNING

DC LOOP voltage and current can present a shock hazard. Do not handle open or exposed leads while the MD-522A/GRC is turned ON.

TM 11-5815-332-15

(2) Check the cables used in the DC LOOP circuit. The following cables are used in the DC LOOP circuit: W3, W6, W7, W15, W16, W17, W18, W19, and jumper from TT-76, TB-1, term. 2 to TT-76, TB-1, term. 7. Check the connectors on these cables to insure that there are no bent or broken pins. When connected, insure that the connections are tight.

(3) Use a piece of insulated wire 2 to 3 feet long.

Insulated wire will help protect repair personnel from shock hazard. Strip one-fourth to one-half inch of insulation from both ends of the wire. Use this wire to make the test shorts, and the MD-522A/GRC test meter to observe the desired deflection.

CAUTION

Before performing the following test functions check to see that the Modem is a MD-522A/GRC.

e. Deflection Indication Chart.

Step	Test function	20-ma deflection	No 20-ma deflection
1	Observe test meter on MD-522A/GRC.	Have repairperson check teletypewriter.	Go to step 2.
2	Disconnect W3 from DC LOOP NO. 1 connector on MD-522A/GRC. Short pins A and C on MD-522A/GRC connector.	Go to step 3. Reconnect W3.	Evacuate MD-522A/GRC to higher maintenance.
3	Disconnect W3 from DC LOOP NO. 1 connector on control box. Short pins A and C on cable connector.	Reconnect W3. Go to step 4.	Check and repair if possible. Replace W3. Resume testing.
4	Short the white and blue banana jacks on dummy box together.	Reconnect banana jacks. Go to step 5.	Check W15 for continuity. Resume testing.
5	Disconnect W7 and W6 from the dummy box. Short pin B of LOOP IN connector on dummy box, to pin B of LOOP OUT connector on dummy box.	Go to step 6.	Evacuate dummy box to higher maintenance.
6	Connect W6 to LOOP OUT connector on dummy box. Short pins B and C at LOOP IN connector on dummy box.	Reconnect W?. Go to step 7. Problem is in W? or beyond.	Reconnect W7. Go to step 10. Problem is in W6 or beyond or in dummy box.
7	Disconnect W? from LOOP IN connector on control box, short pins B and C on cable connector.	Reconnect W7. Go to step 8.	Check W7 and repair if possible, or replace W7. Resume test.
8	Disconnect W16 from control box and connect appropriate dummy plug to TT-76 SEND connection.	Replace W16. Resume test.	Reconnect W16. Go to step 9.
9	Disconnect W18 from control box. Connect appropriate dummy plug to TT-98 SEND connector on control box.	Replace W18. Resume test.	Have repairperson check control box. Resume test.
10	Disconnect W6 from dummy box. Connect appropriate dummy plug to LOOP OUT connector.	Reconnect W6. Go to step 11.	Evacuate dummy box to higher maintenance.
11	Disconnect W6 from control box. Short pins B and C on cable connector.	Reconnect W6. Go to step 12.	Replace W6. Resume test.
12	Disconnect W 17 from control box. Connect appropriate dummy plug to TT-76 REC connector.	Replace W17. Resume test.	Reconnect W17. Go to step 13.
13	Disconnect W19 from control box. Connect appropriate dummy plug to TT-98 REC connection.	Replace W19. Resume test.	Have repairperson check control box.

5-5. Removal and Replacement of Damaged Antenna Mast Sections

The organizational repairperson may replace damaged mast sections of the antenna. Replace the mast sections as follows:

WARNING

During removal, disassembly, assembly, erection, or repair of the whip antenna,

conform to all safety requirements in TB SIG 291. Injury or DEATH could result from failure to comply with safe practices. Disconnect all power from the AN GR-C-106(*) during servicing. (Turn 106(*) RT SERVICE SELECTOR switch to OFF.)
a. Removal of AN/GRC-106() Antenna Mast Sections.*

(1) Slide the plastic antenna sheath up and free of Mast Base AB-652/GR.

(2) Unscrew the lower Mast Sections MS-116A from Mast Base AB-652/GR.

(8) Slide the plastic antenna sheath off the mast sections.

(4) Disassemble the five Mast Section (3 ea MS-116A, 1 ea MS-117A and 1 ea MS-118A) by

unscrewing them.

b. Replacement of AN/GRC-106() Antenna Mast Sections.*

(1) Replace any defective mast section with spares of the same type.

(2) Refer to paragraph 24 for installation procedure.

CHAPTER 6

CIRCUIT FUNCTIONING

6-1. Scope of Circuit Functioning

Only the functioning of the circuits interconnecting and powering standard equipment are covered in this chapter. For circuit functioning of the standard equipment in the AN/VSC-3, refer to the applicable technical manuals (app A).

6-2. Function of Signal Circuits

a. Voice and Cw Circuits. The connections of the voice and cw circuits are shown in figure FO-3. The high side of the microphone circuit is connected from pin L of the control box AUDIO OUT connector through coupling capacitor C3 and CW-VOICE/TTY switch S1 to pin C of the MD-522 MIC connector. When switch S1 is in the TTY position, pin C of connector MD-522 MIC and pin L of the AUDIO OUT connector are connected to ground through capacitors C1 and C2. This shorts voice signals on the microphone circuit to ground during teletypewriter operation. The high side of the received voice circuit from the MD-522(*)/GRC is fed through pin A of the connectors. The RT-662/GRC transmitter keying signal (ground) is fed through pin F of the connector. When the RT-662/GRC is operated in the cw mode from a remote position, ground is applied to pin F of the MD-522 MIC connector from pin A of the REMOTE connector. The ground potential is fed from pin A, through cable W22, the telegraph key pin (fig. 3-4), cable W22 and pin D of the control box REMOTE connector (fig. FO-3). Pins Band H of the MD-522 MIC and AUDIO OUT connectors provide through ground connections.

b. Teletypewriter Dc Signal Circuit. The ac loop connections from the MD-522(*)/GRC to the TT-76(*)/GGC and the TT-98(*)/FG are shown in figure FO-2. When the control box LOCAL-REMOTE switch S3 is in the LOCAL position the loop is closed. When switch S3 is in the REMOTE position, the loop is open. In this mode the loop is completed to a remote teletypewriter through pins E and F of the control box REMOTE connector and cable W22 (fig. 3-4). BLACK-RED switch S2 of the control box connects resistor R2 in and out of the loop circuit. When the switch is in the BLACK position (closed), resistor R2 is shorted out for clear (unsecured) operation. When the switch is in the Red position (open), resistor R2 is

in series with the loop to limit the current during secure operations.

6-3. Power Distribution

(fig. 6-1)

a. General. The 28 vdc is applied from the vehicle power pack through cable W20 and a ground strap. The positive side of the power is fed into the control box through the PWR IN connector. The MAIN circuit breaker consists of two 50-ampere circuit breakers (CB1 and CB2) that are ganged together. When the MAIN circuit breaker is closed, power is distributed through the AN/ASC-3 as given in *b* below.

b. Distribution.

(1) Through CB1 to INVERTER circuit breaker CB3.

(2) Through CB3 and cable W14 to the inverter. The output of the inverter (115 vac) is applied through cable W26 to the TT-76(*)/GGC and to the TT-98(*)/FG through its own cable.

(3) When security equipment is used, the 28 vdc is applied to it through CB1, the DUMMY PWR connector, and cable W5.

(4) Through CB2 to the dc volt meter and indicator lamp L1.

(5) Through CB2, TRANS SUPPRESSOR connector, and cable W 13 to Electrical Transient Suppressor MX-7778/GRC.

(6) The MX-7778/GRC prevents transient spikes in its output voltage. (Transient spike voltage could damage transistorized circuits in the AN/GRC-106(*) or MD-522(*)/GRC.) One output of the MX-7778/GRC is applied to the PWR connector of the RT-662/GRC (p/o AN/GRC-106(*)) through cable W10. The second output of the MX-7778/GRC is applied to the RT-662/GRC (p/o AN/GRC-106(*)) and the MD-522(*)/GRC PWR connectors. Connection is through "Y" cable W23, cable W4, and cable W 12.

(7) When the AN/GRC-106(*) is remote voice operated (fig. 3-4), power is applied to the GRA-6 through pin K of the control box AUDIO connector.

(8) When VOICE-CW, TTY switch S1 is closed, the 28 vdc from CB2 is applied to NON-SECURE VOICE lamp L2. This lights the lamp indicating the mode of operation.

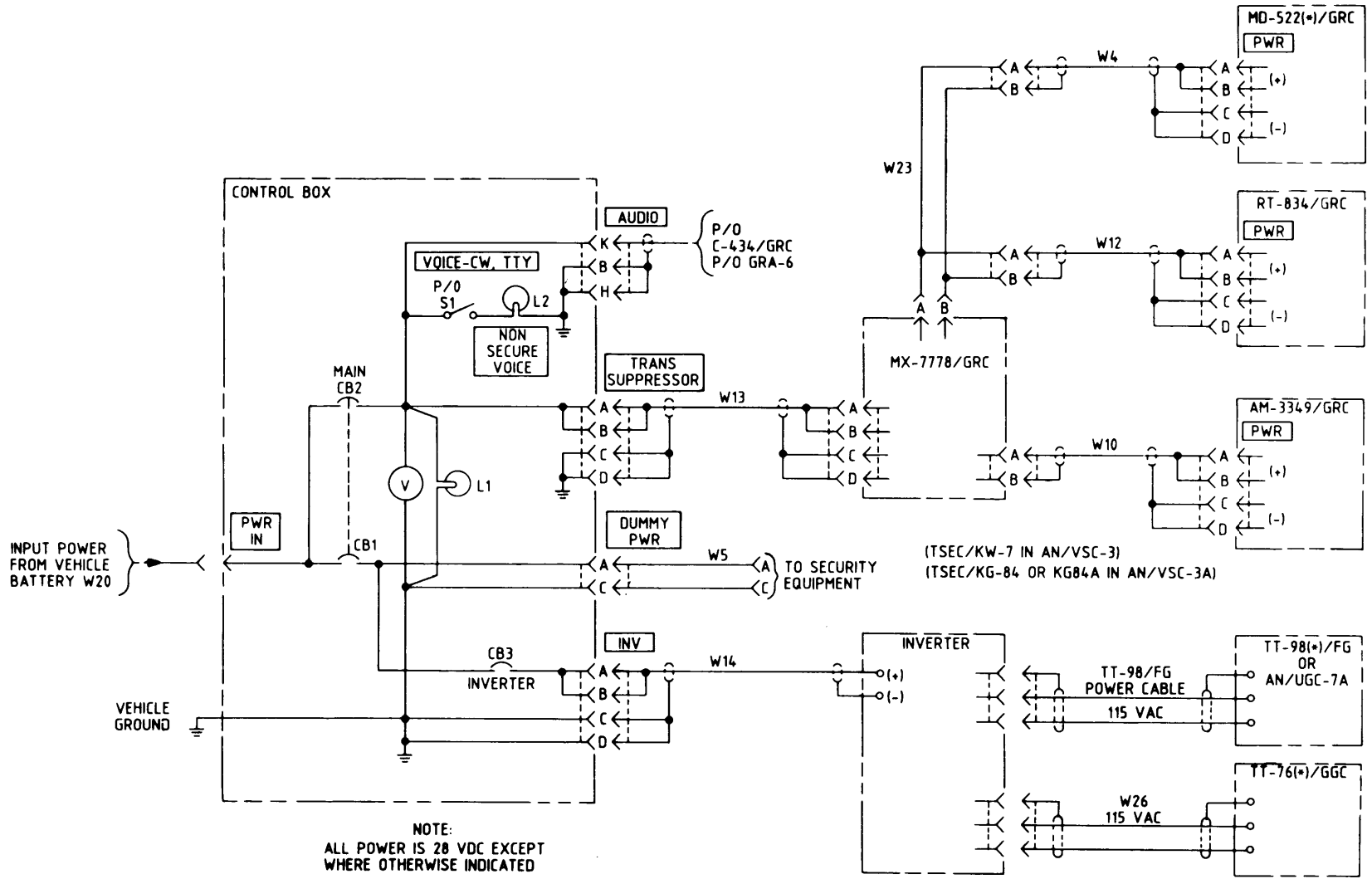

Figure 6 1 Power distribution schematic diagram.

6-4. Function of Secure Circuits.

The AN/VSC-3 and AN/VSC-3A use COMSEC equipment TSEC/KW-7. The AN/VSC-3 (with MK-2488/G) and AN/VSC-3A (with MK-2488/G) use Digital loop Encryption Device TSEC/KG-84A and companion Interconnecting Box J-4024/U (fig. 1-7.1) installed in place of the TSEC/KW-7. The DLED and J-4024/U are connected together with three special cables (fig. 1-5.1). This DLED and J-4024/U

hookup (fig. 6-1.2) converts normal input keying (NIK) and 20 ma neutral current signals to MIL-STD-114 signals for the TSEC/KC-84A signal paths between the teletypewriters and the modem. The AN/VSC-3A (with MK-2488/G) uses the AN/UGC-74A(V)3 in place of the TT-98(*)/FG. The connection from the AN/UGC-74A(V)3 to J-4024/U requires special cable CX-13253 (fig. 1-5.1). The J-4024/U is setup for 28 VDC power input operation. The DLED) receives its power from the J-4024/U.

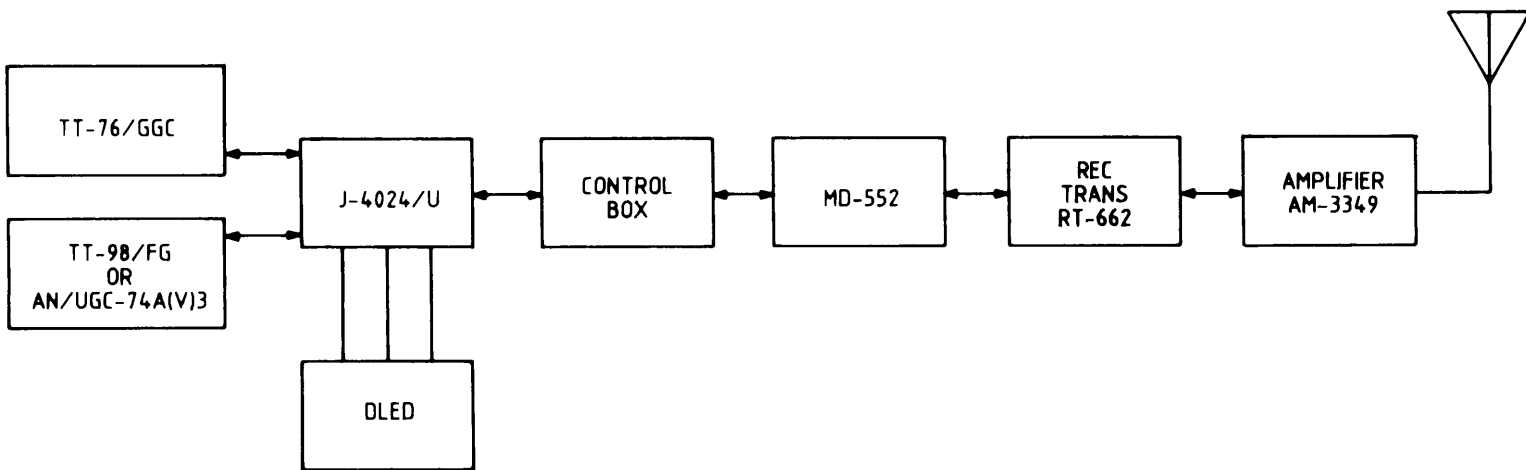

Figure 6-1.2. Signal block diagram for AN/VSC-3 (with MK-2488) and AN/VSC-3A (with MK-2488).

CHAPTER 7 DIRECT AND GENERAL SUPPORT MAINTENANCE

Section I. DIRECT SUPPORT MAINTENANCE

NOTE

Direct support maintenance personnel may perform higher category maintenance procedures provided the maintenance allocation chart authorizes the tools and test equipment required to perform the higher category maintenance procedures.

7-1. Scope of DS Maintenance

Direct support maintenance comprises troubleshooting and replacing of Cable Assembly, Special Purpose, Electrical W24, and the RCV/SEND switch. It also entails the removal and replacement of components peculiar to the AN/VSC-3.

7-2. Cable and Switch Maintenance

Defects in Cable W24 or the RCV/SEND switch can be located by taking continuity checks with Multimeter TS-352B/U. The wiring diagram for cable W24 is shown on figure 7-6. Replace Cable W24 and the RCV/SEND switch if continuity checks indicate a defect.

7-3. Dummy Box, Control Box, and Remote Control Box Replacement

NOTE

Turn the MD-522(*) GRC power off before removing the plugs from the dummy box. The replacement of either the dummy box or the control box for troubleshooting and repair entails disconnecting or reconnecting cables, and the removing and replacing of nuts or bolts from brackets and does not require special instructions other than the note above. Authorized tool kits for direct support maintenance are Tool Kits, Electronic Equipment TK-100/G, and TK-105/G. When not in use the remote control box is kept in the storage box. When it is installed for use or disconnected for replacement a pair of field wires and an audio connector are attached or removed.

Section II. GENERAL SUPPORT MAINTENANCE

7-4 General Instructions

The general support maintenance procedures in this section supplement the categories of lower level maintenance. The systematic troubleshooting procedure, which begins with the operational and sectionalization checks that can be performed at organizational level, is carried to a higher level in this section. Sectionalizing, localizing, and isolating techniques used in the troubleshooting procedures are more advanced.

7-5. Organization of Troubleshooting Procedures

a. General. The first step in servicing the AN/VSC-3 is to sectionalize the fault. Sectionalization means tracing the fault to a major component. If a major component, not peculiar to the AN/VSC3, is sectionalized as faulty, refer to appendix A for the applicable maintenance manuals. Localization means tracing the fault to a defective part responsible for the abnormal condition. Some faults such as burned-out resistors, circuit breakers, and broken switches and connectors can be located by sight, smell, or feel. The majority of

faults, however, must be isolated by checking voltages and resistances.

b. Sectionalization. Listed below is a group of tests arranged to reduce unnecessary work and to aid in tracing trouble in a defective AN/VSC-3. The first step is to locate the unit or units at fault by the following methods:

(1) *Visual inspection.* The purpose of visual inspection is to locate faults without testing or measuring circuits. Meter readings, scope patterns, *or* other visual signs and sounds from the equipment suspected of being faulty should be observed in the attempt to sectionalize the fault to a particular unit.

(2) *Operational tests.* Operational tests frequently indicate the general location of the trouble. In many instances, these tests will help in determining the exact nature of the fault. *For example*, operating in a teletypewriter mode may sectionalize the trouble to the TT-98(*)/FG, MD-522(*)/GRC, inverter, or control box. Refer to chapter 3 for the operating procedures.

c. Localization and Isolation. After the trouble

has been sectionalized, the methods listed in (1) through (4) below will aid in localizing and isolating the trouble to a part or parts in a unit.

(1). Meter indications or the lack of meter indications, and operational checks provide a systematic method of localizing trouble in a unit. The trouble symptoms listed in the troubleshooting chart (para 7-8) provide additional information for localizing troubles.

(2) Voltage, resistance, continuity, and parts substitution checks should enable the repairman to quickly isolate the trouble.

(3) In all of the tests, the possibility of intermittent troubles should not be overlooked. If present, this type of trouble often may be made to appear by jarring the AN/GRC-106(*) MD-522(*)/GRC, TT-98(*)/FG, TT-76(*)/GGC, dummy box, control box, inverter case, or MX 7778/GRC.

(4) Resistor capacitor, and inductor color code charts (FO-1) are provided to aid maintenance personnel in determining the value, voltage rating, and tolerance of resistors capacitors and inductors.

7-6. Test Equipment Required

The only test equipments required, other than those specified in the applicable technical manuals for the AN/GRC-106(*), MX-7778/GRC. TT-98(*)/FG, MD-522(*)/GRC, TT-76(*)/GGC, and TT-523(*)/GGC, are Multimeter TS-352B/U or and a battery eliminator. The battery eliminator is usually used when a unit is being bench-tested.

CAUTION

The AN/VSC-3 contains transistorized circuits in the AN/GRC-106(*), MD-522(*)/GRC, and the TT-523(*)/GGC.

If any test equipment does not have an isolation transformer in its power supply circuit, connect one in its power input circuit.

a. Never connect test equipment (other than multimeters and vacuum tube voltmeters outputs directly to a transistor circuit; use a coupling capacitor. Do not use an ohmmeter if its open circuit voltage exceeds 1.5 volts. Never use the RX 1 range of ohmmeter when testing low power transistors.

b. Make test equipment connections with care so that shorts will not be caused by exposed test equipment connectors. Tape or sleeve (spaghetti) test prods or clips as necessary to leave as little exposed as necessary to make contact to the circuit under test.

c. The vehicle battery (or its equivalent) normally used is recommended as the source of power when servicing transistorized equipment. Observe battery polarity. Polarity reversal may damage transistors or electrolytic capacitors in the circuit. If a battery eliminator is used (when bench testing) in place of the battery normally used with the equipment, it must have good voltage regulation and low ac ripple. Good regulation is important because the output voltage of a battery eliminator which has poor regulation may exceed the maximum voltage rating of the transistors in the equipment being tested.

d. Turn off the transistorized equipment before switching the battery eliminator on or off. Transient voltages, created by switching the battery eliminator on and off can ruin transistors. Also make sure that each transistorized circuit has a normal load (such as the loudspeaker for the AN/GRC-106(*) before applying power.

Section III. GENERAL SUPPORT TROUBLESHOOTING

CAUTION

Do not attempt removal and replacement of components before reading the instructions in section IV.

7-7 Use of General Support Troubleshooting Chart

a. It is assumed in the troubleshooting chart that the AN/VSC-3 is completely installed in the Carrier, Command Post M577A1 (fig. 2-1). Operation of the equipment (chap 3) is required to check the items listed in the *Trouble symptom* column of the troubleshooting chart.

b. The items listed in the Probable trouble column do not necessarily include all possible

troubles but are to be used as a guide by the repairman.

c. Use the schematic diagrams for the control box (fig. 7-1) and the dummy box (fig. 7-2), and the appropriate cabling diagram (fig. 2-1 for the AN/VSC-3, fig. 2-1.1 for the AN/VSC-3A, Fig. 2-1.2 for the AN/VSC-3 (WITH MK-2488/G) and fig. 2-1.3 for the AN/VSC-3A (WITH MK-2488/G) in conjunction with the procedures in the troubleshooting chart.

d. When using the troubleshooting chart, start at the beginning, and follow each step in order if the

trouble is not known. If the trouble is known, proceed directly to the appropriate symptom.

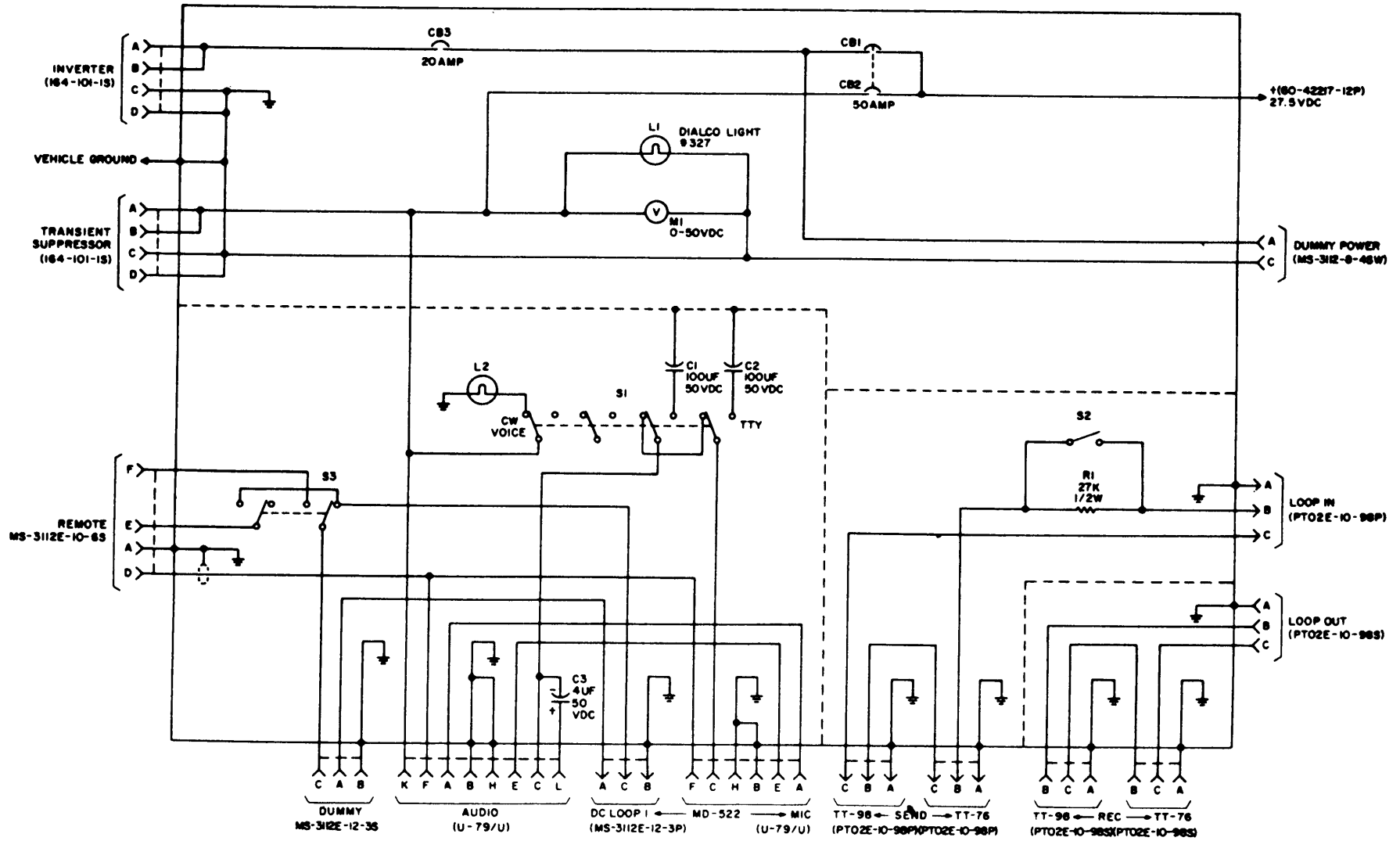

EL5815-332-15-TM-25

Figure 7-1. Control box schematic diagram.

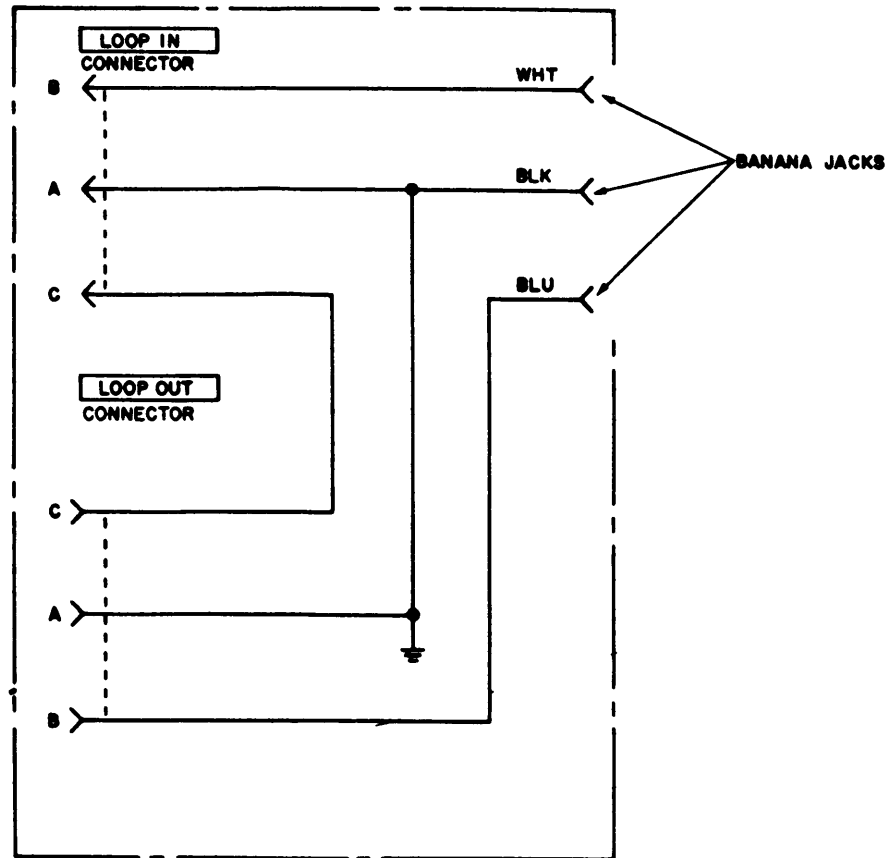

EL5815-332-15-TM-24

Figure 7-2. Dummy box schematic diagram.

7-8. General Support Troubleshooting Chart

Item No.	Trouble symptom	Probable trouble	Corrective measure or reference
1	<p>Control box (fig. 7-1)</p> <p>a. The 27.5VDC lamp and the DC VOLTS meter of the control box do not indicate when MAIN circuit breakers (CB) are ON.</p> <p>b. The 27.5VDC lamp lights and DC VOLTS meter of control box does not indicate.</p> <p>c. DC VOLTS meter indicates and 27.5VDC lamp of the control box does not light.</p> <p>d. RT-662 / GRC does not receive dc input power, but MD-522(*) / GRC does.</p> <p>e. AM-3349 / GRC-106 does not receive dc input power but MD-522(*) / GRC and RT-834 / GRC do.</p>	<p>a. Defective battery connection, cable W20, or control box.</p> <p>b. Defective DC VOLTS meter or internal wiring of the control box.</p> <p>c. Defective 27.5 VDC lamp, lamp holder, or internal wiring of the control box.</p> <p>d. Defective cable W23, or part of W23. Defective RT-662 / GRC receptacle.</p> <p>e. Defective cable W10. Defective AM-3349 / GRC-106 receptacle.</p>	<p>a. Check connections at vehicle battery and the control box. Check cable W20. Schematic diagram for cable W20 is on figure 7-4).</p> <p>b. Check internal wiring of control box. Check the DC VOLTS meter,</p> <p>c. Check 27.5VDC lamp, lamp-holder, and internal wiring of the control box (fig. 7-3).</p> <p>d. Check for 27 volts dc between terminals A and C or W23 which connects to W2. Refer to TM 11-5820-520-34.</p> <p>e. Check for 27 volts dc between terminals A and C of AM-3349 / GRC-106 receptacle. Refer to TM 11-5820-520-34.</p>

Item No.	Trouble symptom	Probable trouble	Corrective measure or reference
	f. MD-522(*)/GRC does not receive input power but other components do.	f. Defective cable W12, or MD-522(*)/GRC.	f. Check for 27vdc between terminals A and C of the MD-522(*)/GRC. If absent, check between terminals A and C of W12. Refer to TM 11-5805-387-15-2.
	g. Inverter does not rotate but other components are operable.	g. Defective cable W14. Defective circuit breaker (CB) on control box, or defective inverter receptacle.	g. Check for 27vdc between terminals A and C at INVERTER receptacle on control box. Check W14 connectors to the inverter for 27vdc. Check CB on control for being open.
	h. Inverter armature rotates but one teletypewriter motor does not rotate.	h. One of the two teletypewriters has a bad motor.	h. Check the inverter 115-volt ac receptacles. Refer to TM 11-5815-200-35 and TM 11-5815-238-35.
2	<i>RT-662/GRC</i>		
	a. No reception.	a. Improper control settings, defective audio accessory, RT-662/GRC, AM-3349/GRC-106, or the antenna.	a. Same as item 1d above. See that AM-3349/GRC-106 PRIM PWR switch is at OPERATE; check audio accessory by substitution; check CX-10171/U (6 ft) and antenna. Refer to TM 11-5820-520-12. Replace RT-662/GRC or AM-3349/GRC-106.
	b. Reception in some modes only (for example, ssb voice but not cw).	b. Defective RT-662/GRC.	b. Refer to TM 11-5820-520-34. Replace RT-662/GRC.
3	<i>AM-3349/GRC-106</i>		
	a. The AM-3349/GRC-106 blower motors do not energize.	a. Defective cable W10, AM-3349/GRC-106, RT-662/GRC, or control box.	a. Same as 1e above. Refer to TM 11-5820-520-34.
	b. AN/GRC-106(*) tunes normally but does not stop transmitting when AM-3349/GRC-106 HV RESET switch is turned to OPERATE.	b. Defective audio accessory, cable W1, control box, RT-662/GRC, or AM-3349/GRC-106, cable W2.	b. Disconnect audio accessory from control box. If AN/GRC-106 stops transmitting, audio accessory is defective. If AN/GRC-106 continues to transmit, disconnect W2 from the control box. If AN/GRC-106 stops transmitting, control box is defective. If AN/GRC-106(*) continues to transmit, disconnect cable W2 from the MD-522(*)/GRC. If AN/GRC-106 stops transmitting, cable W2 is defective. If AN/GRC-106(*) continues to transmit, disconnect cable W1 from MD-522(*)/GRC. If AN/GRC-106(*) stops transmitting, MD-522(*)/GRC is defective. If AN/GRC-106(*) continues to transmit, disconnect cable W1 from RT-662/GRC. If AN/GRC-106(*) stops transmitting, cable W1 is defective. If AN/GRC-106(*) continues to transmit, AM-3349/GRC-106 or RT-662/GRC is defective. Refer to TM 11-5820-520-34.

Item No.	Trouble symptom	Probable trouble	Corrective measure or reference
	<p>c. Reception of signal, but poor or no transmission of signal.</p> <p>d. Unable to transmit.</p>	<p>c. Defective cable CX-10171/U, antenna, or AN/GRC-106(*).</p> <p>d. Same as b above</p>	<p>c. Check CX-10171/U and antenna. Refer to TM 11-5820-520-34.</p> <p>d. Connect substitute audio accessory to RT-662/GRC AUDIO connector. If transmission is not possible, refer to TM 11-5820-520-34; if transmission is possible, check cables W1 and W2, control box, and original audio accessory. If these are not defective, MD-522(*)/GRC is defective. Refer to TM 11-5805-387-15-2.</p>
4	MD-522(*)/GRC		
	<p>a. Voice reception at RT-662/GRC AUDIO connector but not at loudspeaker.</p> <p>b. No teletypewriter dc loop current in any tty mode.</p>	<p>a. Defective cable W1, loudspeaker, or MD-522(*)/GRC (fig. 2-1).</p> <p>b. Defective MD-522(*)/GRC. TT-98(*)/FG, TT-76(*)/GGC, cables W15, W6, W7, control box, or dummy box.</p>	<p>a. Check cable W1 and loudspeaker; if these are not defective, MD-522(*)/GRC is defective. Refer to TM 11-5805-387-15-2.</p> <p>b. Check for 80 volts dc between white and blue banana plugs of dummy box; if not present, check cables W15, and associated receptacles and internal wiring of dummy box; if present, check cables W6, W7, and associated receptacles and internal wiring of dummy box; if none of these is defective, TT-98(*)/FG LINE CURRENT control is maladjusted, or TT-76(*)/GGC is defective. Refer to TM 11-5815-200-35 and TM 11-5815-238-35.</p>
	<p>c. Tty operation is normal in some modes but not in other (for example, 850 Hz but not 85 Hz).</p>	<p>c. Defective MD-522(*)/GRC.</p>	<p>c. Refer to TM 11-5805-387-15-2. Replace MD-522(*)/GRC.</p>
5	TT-98(*)/FG		
	<p>a. No transmission possible from TT-98(*)/FG keyboard.</p> <p>b. TT-98(*)/FG motor fails to start with MOTOR switch at ON.</p> <p>c. Test message sent from keyboard prints incorrectly on page printer.</p> <p>d. TT-98(*)/FG keyboard transmits incorrect code groups.</p>	<p>a. SEND-LOCK switch on TT-98(*)/FG at LOCK.</p> <p>b. No ac input power to TT-98(*)/FG. Defective TT-98(*)/FG.</p> <p>c. Maladjusted TT-98(*)/FG.</p> <p>d. Defective TT-98(*)/FG.</p>	<p>a. Check that SEND-LOCK switch on the TT-98(*)/FG is at SEND. Refer to TM 11-5815-200-12.</p> <p>b. Check ac output from inverter. Check TT-98(*)/FG motor. Refer to TM 11-5815-200-12.</p> <p>c. Check motor speed, check current in the bias circuit, and check the rangefinder mechanism. Refer to TM 11-5815-200-12.</p> <p>d. Refer to TM 11-5815-200-35.</p>

<i>Item No.</i>	<i>Trouble symptom</i>	<i>Probable trouble</i>	<i>Corrective measure or reference</i>
	e. TT-98(*)/FG page printer prints errors or garble.	e. Defective TT-98(*)/FG.	e. If RT-662/GRC and ME-522(*)/GRC operate normally, refer to TM 11-5815-200-35.
6	<i>TT-76(*)/GGC</i> a. No transmission possible from TT-76(*)/GGC keyboard.	a. KEYBOARD switch in the LOCK position (fig. 2-1).	a. Check that the KEYBOARD switch is in the SEND position. Refer to TM 11-5815-238-12.
7	b. TT-76(*)/GGC will not operate. <i>TT-4C/TG (at remote site)</i> a. TT-4C/TG DC MILLIAMPERES meter pointer indicates 0 when any mode of tty operation is attempted.	b. Blown fuses. a. Open dc tty loop, control box LOCAL REMOTE switch at LOCAL, blown TT-4C/TG line fuse, or loose TT-4C/TG terminal board connection. Defective TT-4C/TG.	b. Check equipment fuses. a. Check TT-4C/TG LINE fuse and connections (TM 11-5815-206-12). Higher category maintenance required.
	b. TT-4C/TG motor fails to start with MOTOR switch at ON.	b. No ac input power to TT-4C/TG. Defective TT-4C/TG.	b. Check output from power unit used at remote site. Refer to TM 11-5815-206-12.
	c. Test message sent from keyboard prints incorrectly on page printer.	c. Maladjusted TT-4C/TG.	c. Check TT-4C/TG motor speed, ARMATURE, and RANGE dials (TM 11-5815-206-12).
	d. TT-4C/TC keyboard transmits incorrect code groups.	d. Defective TT-4C/TG.	d. Refer to TM 11-5815-206-12.
	e. TT-4C/TC page printer prints errors or garble when transmitting from keyboard.	e. Defective TT-4C/TG.	e. Refer to TM 11-5815-206-12.
8	<i>AN/UGC-74A(V)S</i> a. Self Test fails.	a. System will print out a fail message and cite assembly being tested.	a. Recheck settings. b. Notify higher Maintenance.
	b. Print drum does not rotate.	b. Out of paper.	a. Replace paper. b. Notify higher Maintenance.
	c. Messages received garbled.	c. Beyond operators capability.	a. Notify higher Maintenance.
	d. Messages transmitted garbled.	d. Beyond operators capability.	a. notify higher Maintenance.

7-8.1 Troubleshooting the J-4024/U and TSEC/KG-84A in the AN/VSC-3 (WITH MK-2488/G and AN/VSC-3A (WITH MK-2488/G

troubleshooting the Interconnecting Box J-4024/U and the associated DLED. Perform the tests in the order listed.

The chart below gives a number of procedures for

Malfunction	Test or inspection	Corrective action
1.	PWR on green indicator lamp DS1 does not light when PWR switch is turned to ON.	<p>Step 1. Turn the PWR SWITCH to OFF.</p> <p>Step 2. Verify that the POWER SOURCE SELECTOR SWITCH S2 on the rear of the J-4024/U is the same voltage as that available from the shelter power distribution (28 VDC position).</p> <p>Step 3. Turn the PWR switch on the front panel to ON. If these steps do not solve the problem, proceed to Step 4.</p> <p>Step 4. Turn the PWR switch to OFF.</p> <p>Step 5. Remove and inspect the proper fuse(s) for the J-4024/U operating voltage (F1 for 115 VAC, F1 and F2 for 230 VAC, or F3 for 28 VDC.) If the fuse(s) are good, replace them and refer the problem to higher echelon maintenance.</p> <p>Step 6. Remove a fuse of the proper value from the SPARE fuse holder on the front panel.</p> <p>Step 7. Replace the burned out fuse with the spare fuse and insert the fuse and fuse holder in its socket.</p> <p>Step 8. Turn the PWR switch on the front panel to the ON position. If these steps do not solve the problem, refer the problem to higher echelon maintenance. If problem is solved, proceed to Step 9.</p> <p>Step 9. Operate the POWER switch on the front panel of the TSEC/KG-84A. If the green POWER indicator light does not light, refer the problem to higher echelon maintenance.</p>

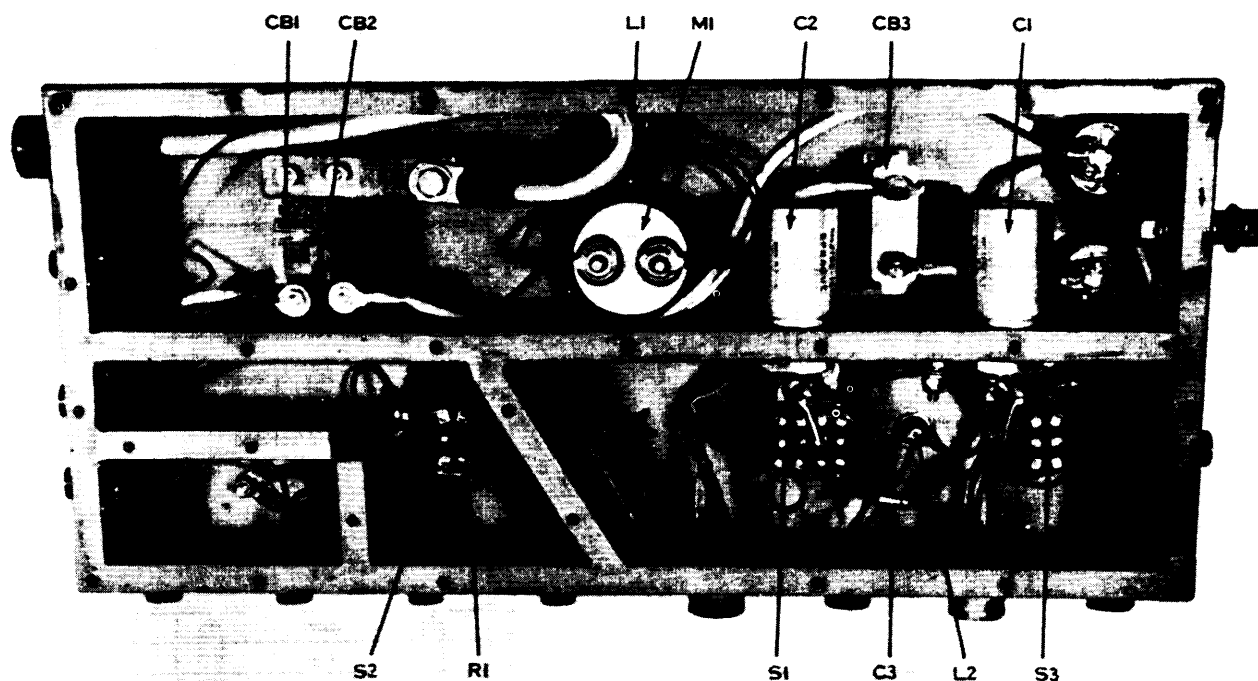

EL5815-332-15-TM-25

Figure 7-3. Rear view of control box with the rear cover removed.

Section IV. GENERAL SUPPORT REPAIR

7-9. Control Box Maintenance

The control box parts locations are shown on figure 7-3. To gain access to these parts, remove the 28 screws that secure the back cover. Suspected troubles can be verified by making continuity checks. The removal or replacement of faulty parts does not require special instructions.

7-10. Cable repair

The interconnecting cable schematic diagrams used with the AN/VSC-3 are shown on figures 7-4, 7-5, and 7-6. The point of trouble in any one of these cables can be located by making non-continuity checks with the TS-352B/GRC. These

cables can be repaired by replacing the connectors or by removing the connectors and using them on new lead wires.

7-11. Repairing AN/VSC-3 Components

Major components of the AN/VSC-3 can be removed from the M577A1 and replaced by operational components known to be in good repair. For example, a defective MD-522(*)/GRC can be removed and replaced by another known good MD-522(*)/GRC. Refer to appendix A for the applicable technical manual. In the case above, the technical manual for the MD-522(*)/GRC is TM 11-5805-387-35P-1 or TM 11-5805-387-35P-2.

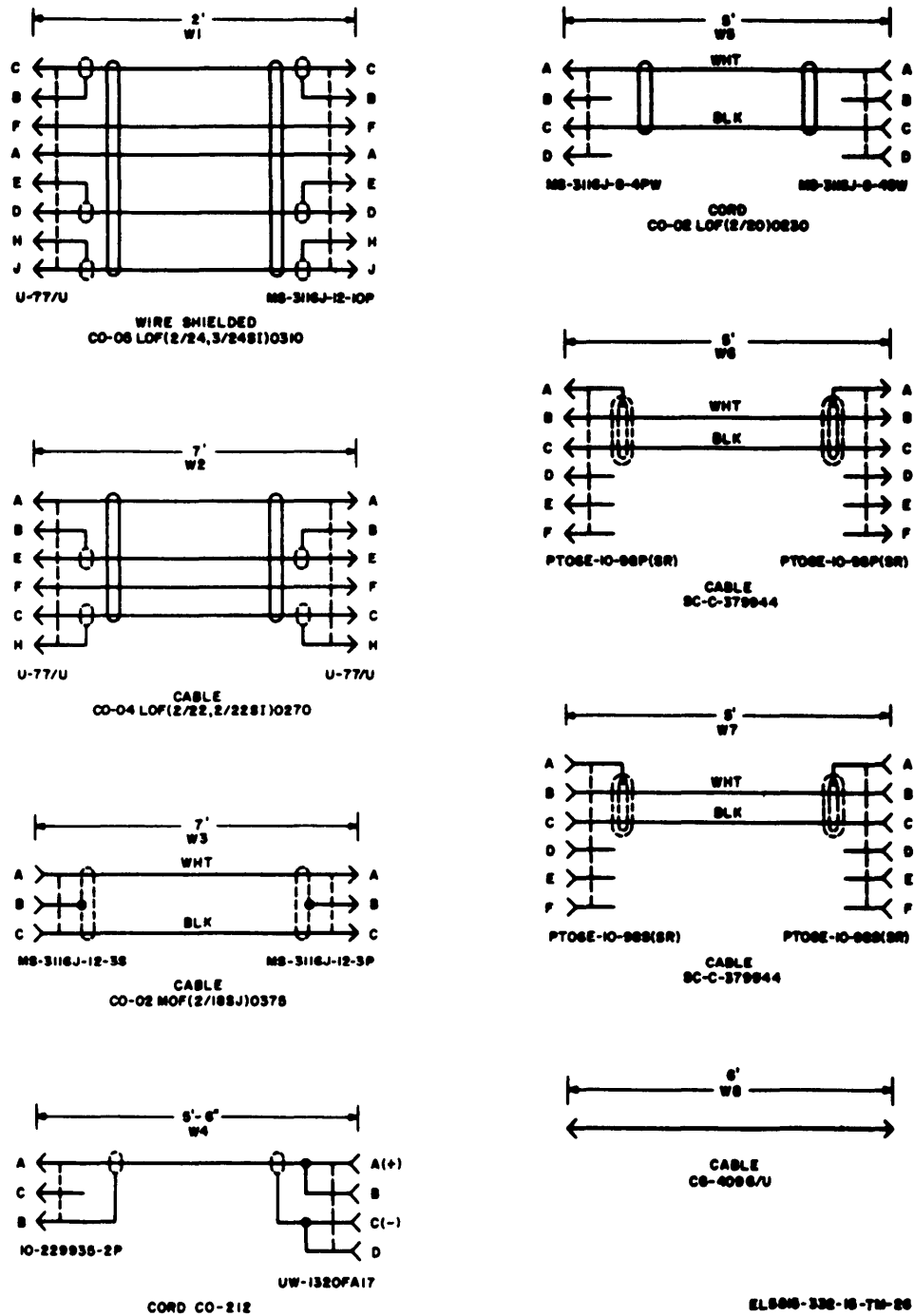

EL5815-332-15-TM-26

Figure 7-4. Wiring diagrams for interconnecting cable W1 through W8.

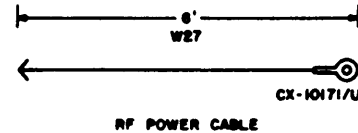
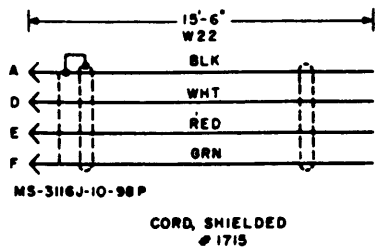
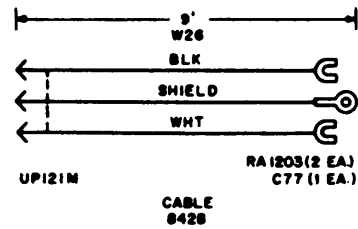
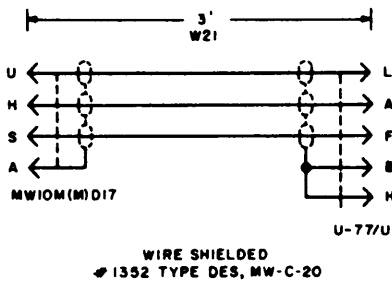
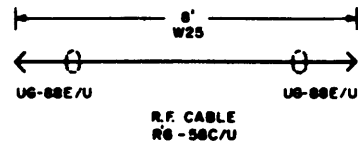
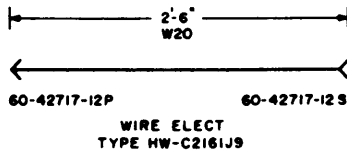
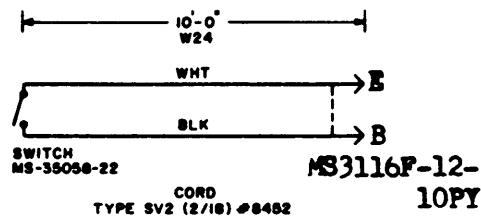
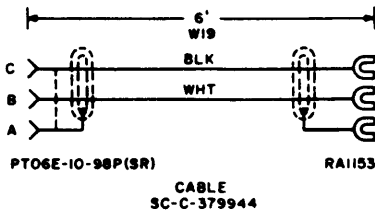
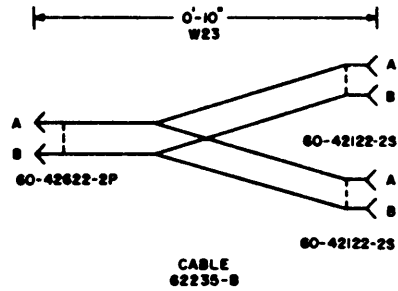
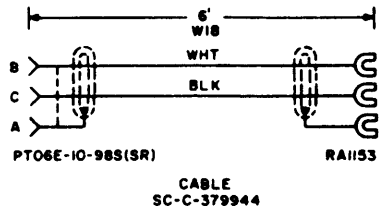

EL5815-332-15-TM-28

Figure 7-6. Wiring diagrams for interconnecting cables W18 through W27.

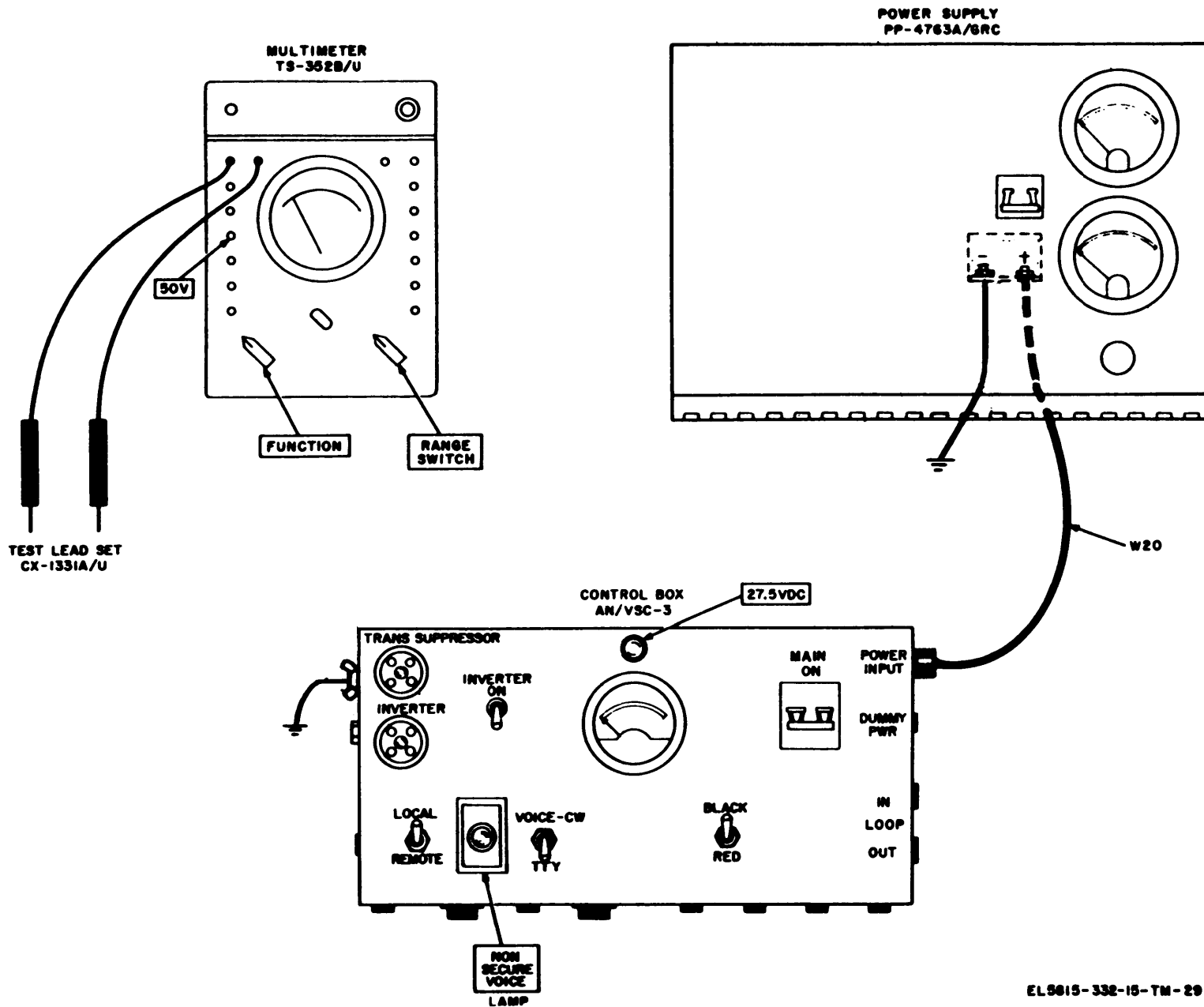
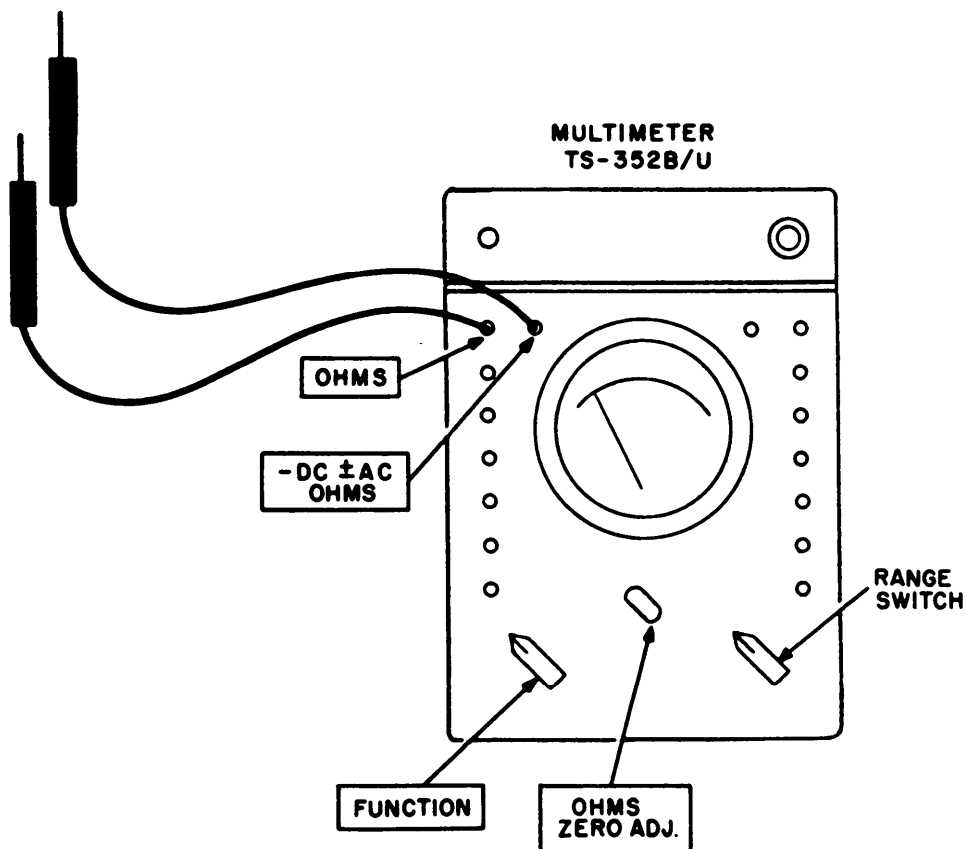
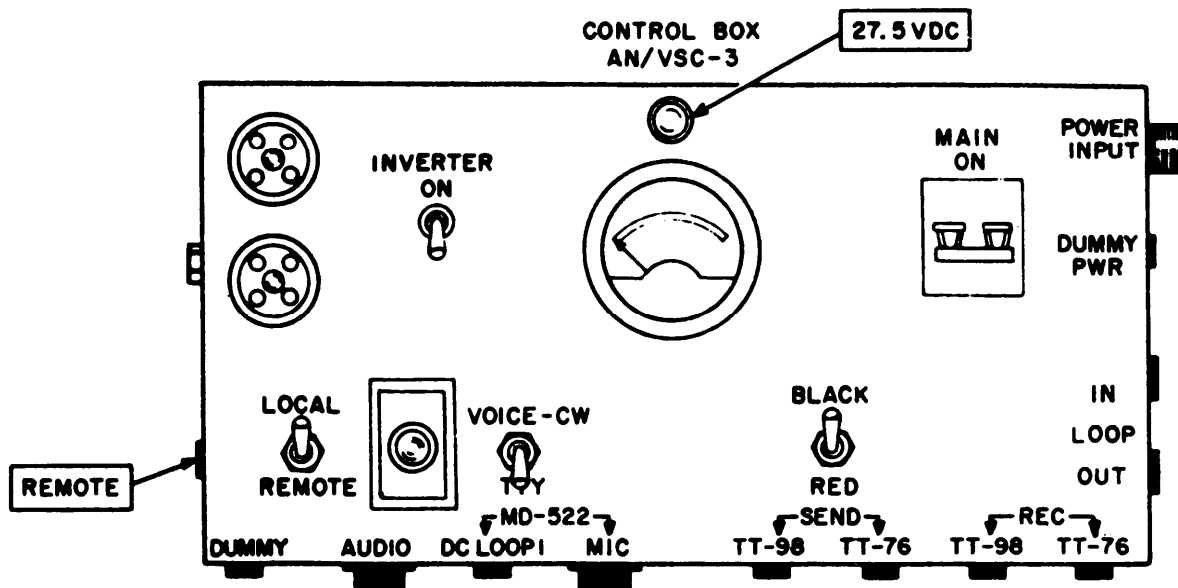

Figure 7-7. Voltage test procedure hookup.



EL5815-332-15-TM-30

Figure 7-8. Continuity test procedure hookup.

Section V. GENERAL SUPPORT TESTING

7-12. General

A repaired control box, peculiar to the AN/VSC-3, must be tested prior to its return to field users. The tests outlined in the following paragraphs will be used to verify that a repaired control box is functioning correctly.

7-13. Control Box Voltage Tests

a. *Equipment Hookup for Testing.* Connect the

c. *Test Procedures.*

Step No.	Test equipment control setting	Equipment under test control settings	Test procedure	Performance standard
1	TS-352B/U FUNCTION switch: DIRECT PP-4763A/GRC Adjust for 27.5 vdc output.	Control box MAIN circuit breakers CB1 and CB2: ON INVERTER circuit breaker CB3: ON CW VOICE-TTY switch to: CW VOICE	a. Observe dial lamp.... b. Observe DC VOLTMETER. c. Observe NON-SECURE VOICE lamp.	a. Dial lamp glows. b. DC VOLTMETER reads: 27.5 vdc. c. Lamp lights in CW VOICE position.
2	Same as step 1 above.	Same as step 1 above.	a. Measure the dc voltage between A and C of the DUMMY PWR connector. b. Measure dc voltage between A and C of INVERTER connector. c. Measure dc voltage between A and C of TRANS SUPPRESSOR connector.	a. 27.5 vdc. b. 27.5 vdc. c. 27.5 vdc.

7-14. Control Box Continuity Tests

a. *Equipment Hookup for Testing.* Connect equipment as shown in figure 7-8, to perform the test procedures in c below.

c. *Test Procedures*

Step No.	Test equipment control settings	Equipment under test control settings	Test procedure	Performance standard
1	TS-352B/U FUNCTION switch: OHMS Range switch: RX1	Control box LOCAL REMOTE switch: LOCAL VOICE-CW, TTY switch: VOICE-CW INVERTER switch: OFFMAIN switch:OFF	a. Measure continuity between C of LOOP IN and C of TT-98-SEND. b. Measure continuity between C of LOOP OUT and C of REC-TT-76. c. Measure continuity between B of LOOP OUT and B of TT-98-REC.	a. 0 ohm. b. 0 ohm. c. 0 ohm.
2	Same as step 1 above except that range switch is at RX1000.	Same as step 1 above.	a. Measure the continuity between B of LOOP IN and B of SEND-TT-76, with RED BLACK switch in BLACK. b. Measure the continuity between B of LOOP IN and B of SEND-TT-76, with RED BLACK switch in RED.	a. 0 ohm. b. 27K ohms ± 5%.

equipment as shown in figure 7-7, to perform the test procedures in c below.

b. *Equipment Required* Multi meter TS-352B/U or is required to perform the tests in c below.

- (1) Multimeter TS-352B/U.
- (2) Power Supply PP-4763A/GRC.

b. *Equipment Required.* Multimeter TS-352B/U is required to perform the tests in c below or AN/PSM-45.

Step No.	Test equipment control settings	Equipment under test control setting.	Test procedure	Performance standard
3	Same as step 1 above.	Same as step 1 above.	a. Measure continuity between C of DUMMY connector and C of DC LOOP 1 MD-522. b. Place LOCAL REMOTE switch to REMOTE and measure continuity between E of REMOTE connector and C of DC LOOP 1 MD-522.	a. 0 ohm. b. 0 ohm.

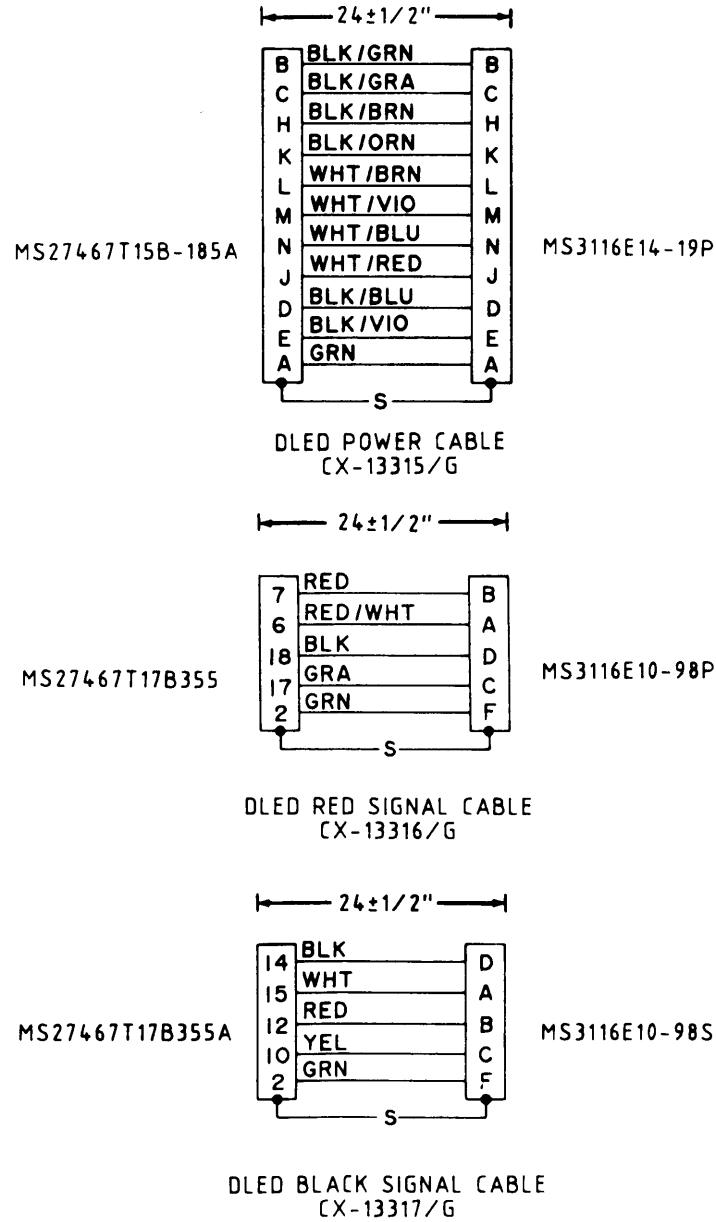

Figure 7-9. Wiring diagram for cables used with J-4024/U.

CHAPTER 8

DEPOT OVERHAUL STANDARDS

8-1. Applicability of Depot Overhaul Standards

a. The tests outlined in this chapter are designed to measure the performance capability of a repaired equipment. Equipment that is returned to stock should meet the standards given in these tests.

b. Applicable procedures of the Army depots performing these tests and the general standards for repaired electronic equipment given in TB SIG 355-1, TB SIG 355-2, and TB SIG 355-3 form a part of the requirements for testing this equipment.

8-2. Test Procedures

a. The test equipment and power required for

depot overhaul standards (DOS) are the same as indicated in paragraphs 7-13 and 7-14.

b. The operational tests for a DOS are the same as the test given in paragraphs 7-13 and 7-14. Perform the tests in the order in which they are given, and see that the results meet the minimum standard indicated in each test.

c. A repaired component used as part of the AN/VSC-3 which has its own technical manual must meet the requirements for a DOS given in its TM; or if no DOS is available, they must meet the General Support testing requirements.

CHAPTER 9

ADMINISTRATIVE STORAGE

9-1 .General

Some equipments that will not be used for short **periods of time (1 to 45 days) should be put in** administrative storage. This will help prevent the equipment from being damaged due to unforeseen circumstances.

9-2. Administrative Storage Procedures

The AN/VSC-3 will be placed in administrative storage by performing the following:

a. Perform the operator and organizational preventive maintenance checks and services (PMCS)

procedures **on the system and on each component of the system that requires PMCS.**

b. Equipments that require batteries to function, should have the batteries removed, such as Control Group AN/GRA-6 (if used).

c. Whip antenna elements should be removed and stored inside the shelter. The mast base will not be removed.

d. To place the equipment back into operation, install the antenna elements, replace batteries, and perform the PMCS procedures.

APPENDIX A REFERENCES

The following list of applicable references are available for technician of Radio Teletypewriter Set AN/VSC-3.

DA Pam 25-30	Consolidated Index of Army Publications and Blank Forms.
DA Pam 738-750	The Army Maintenance Management System (TAMMS).
SC 5180-91-CL-R07	Tool Kit, Electronic Equipment TK-105/G
SC 5180-91-CL-R13	Tool Kit, Electronic Equipment TK-101/G
SC 5180-91-CL-S21	Tool Kit, Electronic Equipment TK-100/G
TB 43-0129	Safety Measures to be Observed When Installing and Using Whip Antennas, Field Type Masts, Towers, Antennas, and Metal Poles That Are Used With Communication, Radar, and Direction Finder Equipment.
TB 43-0118	Field Instructions for Painting and Preserving Electronics Command Equipment Including Camouflage Pattern Painting of Electrical Equipment Shelters.
TM 11-5805-387-15-1	Operator's, Organizational, DS, GS, and Depot Maintenance Manual: Modem, Radio Teletypewriter MD-522/GRC.
TM 11-5805-387-15-2	Operator's, Organizational, DS, GS, and Depot Maintenance Manual: Radio Teletypewriter Modem MD-522A/GRC.
TM 11-5805-387-24P-1	Organizational, Direct Support, and General Support Maintenance Repair Parts and Special Tools Lists (Including Depot Maintenance Repair Parts and Special Tools) for Modem, Radio Teletypewriter MD-522/GRC (NSN 5815-00-999-5277).
TM 11-5805-387-20P-2	Organizational Repair Parts List: Modem, Radio Teletypewriter MD-522A/GRC.
TM 11-5805-387-34P-2	Direct Support, General Support, and Depot Maintenance Repair Parts and Special Tools Lists: Radio Teletypewriter Modem MD-522A/GRC.
TM 11-5815-200-12	Operator's and Organizational Maintenance Manual: Teletypewriter Sets AN/-FGC-20, AN/FGC-20X, AN/FGC-21, AN/FGC-66, AN/FGC159, AN/FGC-159X, AN/FGC-160, AN/FGC-177, AN/UGC-4, AN/UGC-29, AN/UGC-29X and Teleprinter TT-259TG.
TM 11-5815-238-10	Operator's Teletypewriter Sets: AN/GGC3, AN/GGC-3A/AN/GGC-53, and AN/GGC-53A and Teletypewriter Reperforator-Transmitters TT-76/GGC, TT-76MGGC, TT-76B/GGC, TT-76C/GGC, TT-76/GGC, TT-669A/GGC, TT-699B/GGC, TT-699C/GGC.
TM 11-5815-238-35	DS, GS, and Depot Maintenance Manual: Teletypewriter Sets AN/GGC-3 and AN/GGC-3A, AN/GGC-53, and AN/GGC-53A and Teletypewriter Reperforator-Transmitters TT-76/GGC, TT-76A/GGC, TT-76B/GGC and TT-77C/GGC, TT-699/GGC, TT-699A/GGC, TT-699B/GGC and TT-699C/GGC.

TM 11-5815-332-15

TM 11-5815-332-15-HR Hand Receipt Manual Covering End Item/Components of End Item (COEI), Basic Issue Items (BII) and Additional Authorization List (AAL) for Radio Teletypewriter Set AN/VSC-3.

TM 11-5815-338-15 Operators Organizational, DS, GS, and Depot Maintenance Manual Including Repair Parts and Special Tools List: Device, Low-Level Signaling, TT-523/GGC and TT-523A/GGC.

TM 11-5815-602-10 Operator's Maintenance Manual, Terminal Communications AN/UGC-74A(V)3.

TM 11-5820-520-10 Operator's Maintenance Manual Including Repair Parts and Special Tools Lists: Radio Set AN/GRC-106 (NSN 5820-00-167-8003) and Radio Set AN/GRC-106A (NSN 5820-00-167-8005).

TM 11-5820-520-34 Direct Support and General Support Maintenance Manual: Radio Set AN/GRC-106 (NSN 5820-00-167-8003) and Radio Set AN/GRC-106A (NSN 5820-00-167-8005).

TM 11-5830-340-12 Operator's and Organizational Maintenance Manual: Intercommunication Set AN/VIC-1(V).

TM 11-5915-223-24P Operator's and Organizational Maintenance Manual Including Repair Parts and Special Tools Lists: Suppressor, Electrical Transient MX-7778/GRC.

TM 11-5915-223-35 Direct Support, General Support and Depot Maintenance Manual Including Repair Parts and Special Tools Lists: Electrical Transient Suppressor MS-7778/GRC.

TM 11-5965-222-14P Operator's, Organizational, Direct Support, and General Support Maintenance Repair Parts and Special Tools Lists (Including Depot Maintenance Repair Parts and Special Tools): Dynamic Loudspeaker LS-166/U (FSN 5965-243-6420).

TM 11-6625-203-12 Operator and Organizational Maintenance: Multi meter AN/URM-105 and AN/URM-105C Including Multimeter ME-77/U and ME-77C/U.

TM 11-6625-320-12 Operator's and Organizational Maintenance Manual: Voltmeter, Meter, ME-30A/U and Voltmeters, Electronic ME-30B/U, ME-30C/U, and ME-30E/U.

TM 750-244-2 Procedures for Destruction of Electronic Materiel to Prevent Enemy Use (Electronics Command).

APPENDIX B

MAINTENANCE ALLOCATION

Section I. INTRODUCTION

B-1. General

This appendix provides a summary of the maintenance operations for AN/VSC-3 and AN/VSC-3A. It authorizes levels of maintenance for specific maintenance functions on repairable items and components and the tools and equipment required to perform each function. This appendix may be used as an aid in planning maintenance operations.

B-2. Maintenance Functions

Maintenance functions will be limited to and defined as follows:

a. *Inspect.* To determine the serviceability of an item by comparing its physical, mechanical, and/or electrical characteristics with established standards through examination.

b. Test. To verify serviceability and to detect incipient failure by measuring the mechanical or electrical characteristics of an item and comparing those characteristics with prescribed standards.

c. *Service.* Operations required periodically to keep an item in proper operating condition, i.e., to clean (decontaminate), to preserve, to drain, to paint, or to replenish fuel, lubricants, hydraulic fluids, or compressed air supplies.

d. *Adjust.* To maintain, within prescribed limits, by bringing into proper or exact position, or by setting the operating characteristics to the specified parameters.

e. *Aline.* To adjust specified variable elements of an item to bring about optimum or desired performance.

f. *Calibrate.* To determine and cause corrections to be made or to be adjusted on instruments or test measuring and diagnostic equipments used in precision measurement. Consists of comparisons of two instruments, one of which is a certified standard of known accuracy, to detect and adjust any discrepancy in the accuracy of the instrument being compared.

g. *Install* The act of emplacing, seating, or fixing into position an item, part, module (component or assembly) in a manner to allow the proper functioning of the equipment or system.

h. *Replace.* The act of substituting a serviceable like type part, subassembly, or module (component or assembly) for an unserviceable counterpart.

i. *Repair.* The application of maintenance services (inspect, test, service, adjust, align, calibrate, replace) or other maintenance actions (welding, grinding, riveting, straightening, facing, remachining, or resurfacing) to restore serviceability to an item by correcting specific damage, fault, malfunction, or failure in a part, subassembly, module (component or assembly), end item, or system.

j. *Overhaul.* That maintenance effort (service/action) necessary to restore an item to a completely serviceable/operational condition as prescribed by maintenance standards (i.e., DMWR) in appropriate technical publications. Overhaul is normally the highest degree of maintenance performed by the Army. Overhaul does not normally return an item to like new condition.

k. *Rebuild.* Consists of those services/actions necessary for the restoration of unserviceable equipment to a like new condition in accordance with original manufacturing standards. Rebuild is the highest degree of materiel maintenance applied to Army equipment. The rebuild operation includes the act of returning to zero those age measurements (hours, miles, etc.) considered in classifying Army equipments/components.

B-3. Column Entries

a. *Column 1, Group Number.* Column 1 lists group numbers, the purpose of which is to identify components, assemblies, subassemblies, and modules with the next higher assembly.

b. *Column 2, Component/Assembly.* Column 2 contains the noun names of components, assemblies subassemblies, and modules for which maintenance is authorized.

c. *Column 3, Maintenance Functions.* Column 3 lists the functions to be performed on the item listed in column 2. When items are listed without maintenance functions, it is solely for purpose of having the group numbers in the MAC and RPSTL coincide.

d. *Column 4, Maintenance Level.* Column 4 specifies, by the listing of a "work time" figure in the appropriate subcolumn(s), the lowest level of maintenance authorized to perform the function listed in column 3. This figure represents the active time required to perform that maintenance function at the indicated level of maintenance. If the number or complexity of the tasks within the listed maintenance function vary at different maintenance levels, appropriate "work time" figures will be shown for each level. The number of task-hours specified by the "work time" figure represents the average time required to restore an item (assembly, subassembly, component, module, end item or system) to a serviceable condition under typical field operating conditions. This time includes preparation time, troubleshooting time, and quality assurance/quality control time in addition to the time required to perform the specific tasks identified for the maintenance functions authorized in the maintenance allocation chart. Subcolumns of column 4 are as follows:

UNIT

- C - Crew/Operator
- O - organizational

INTERMEDIATE

- F - Direct Support
- H - General Support

DEPOT

- D - Depot

e. *Column 5, Tools and Equipment.* Column 5 specifies by code, those common tool sets (not individual tools) and special tools, test, and support equipment required to perform the designated function.

f. Column 6, Remarks. Column 6 contains an alphabetic code which leads to the remark in section IV, Remarks, which is pertinent to the item opposite the particular code.

B-4. Tool and Test Equipment Requirements (Sect. III and IV)

a. Tool or Test Equipment Reference Code. The numbers in this column coincide with the numbers used in the tools and equipment column of the MAC. The numbers indicate the applicable tool or test equipment for the maintenance functions.

b. Maintenance Level. The codes in this column indicate the maintenance level allocated the tool or test equipment.

c. Nomenclature. This column lists the noun name and nomenclature of the tools and test equipment required to perform the maintenance functions.

d. National/NATO Stock Number. This column lists the National/NATO stock number of the specific tool or test equipment.

e. Tool Number. This column lists the manufacturer's part number of the tool followed by the Federal Supply Code for manufacturers (5-digit) in parentheses.

B-5. Remarks (Sect. IV)

a. Reference Code. This code refers to the appropriate item in section II, column 6.

b. Remarks. This column provides the required explanatory information necessary to clarify items appearing in sections II and V.

**Section II. MAINTENANCE ALLOCATION CHART
FOR
RADIO TELETYPEWRITER SET AN/VSC-3 AND AN/VSC-3A**

(1) GROUP NUMBER	(2) COMPONENT/ ASSEMBLY	(3) MAINTENANCE FUNCTION	(4) MAINTENANCE LEVEL					(5) TOOLS AND EQPT	(6) REMARKS
			C	O	F	H	D		
00	RADIO TELETYPE- WRITER AN/VSC-3, AN/VSC-3A	Inspect	0.2						A
		Test		0.2				1	B
		Test			0.5			3	C
		Install			20.0			4,5	
		Repair			0.3			2	D,Q
		Repair				1.0		4,5	E,Q
		Repair					1.0	4,5	Q
		Rebuild					5.0	4,5	R
0101	CABLE ASSEMBLY, POWER (W14), SCD446242-4-6	Inspect	0.1						
		Test		0.1				1	B
		Service		0.1					
		Replace		0.1				2	P
		Repair						0.1	4,5
0102	CABLE ASSEMBLY, (W9) SCD446030	Inspect	0.1						
		Test		0.1				1	B
		Service		0.1					
		Replace		0.1				2	P
		Repair						0.1	4,5
0103	CABLE ASSEMBLY, (W20) SCD446495	Inspect	0.1						
		Test		0.1				1	B
		Service		0.1					
		Replace		0.1				2	P
		Repair						0.1	4,5
0104	CABLE ASSEMBLY, (W5) SCD446021	Inspect	0.1						
		Test		0.1				1	B
		Service		0.1					
		Replace		0.1				2	P
		Repair						0.1	4,5
0105	CABLE ASSEMBLY, SPECIAL PURPOSE (W6, W7) SCD690550	Inspect	0.1						
		Test		0.1				1	B
		Service		0.1					
		Replace		0.1				2	P
		Repair						0.1	4,5

**Section II. MAINTENANCE ALLOCATION CHART
FOR
RADIO TELETYPEWRITER SET AN/VSC-3 AND AN/VSC-3A**

(1) GROUP NUMBER	(2) COMPONENT/ ASSEMBLY	(3) MAINTENANCE FUNCTION	(4) MAINTENANCE LEVEL					(5) TOOLS AND EQPT	(6) REMARKS
			C	O	F	H	D		
0106	CABLE ASSEMBLY, SPECIAL PURPOSE (W17, W19) SCD37993	Inspect	0.1						
		Test		0.1				1	B
		Service		0.1					
		Replace		0.1				2	P
		Repair					0.1	4,5	Q
0107	CABLE ASSEMBLY, SPECIAL PURPOSE (W16, W18) XC-9994/VC7FR6IN	Inspect	0.1						
		Test		0.1				1	B
		Service		0.1					
		Replace		0.1				2	P
		Repair					0.1	4,5	Q
0108	CABLE ASSEMBLY, SPECIAL PURPOSE (W2) SCD446035	Inspect	0.1						
		Test		0.1				1	B
		Service		0.1					
		Replace		0.1				2	P
		Repair					0.1	4,5	Q
0109	CABLE ASSEMBLY, SPECIAL PURPOSE (W21) SCD446486-2	Inspect	0.1						
		Test		0.1				1	B
		Service		0.1					
		Replace		0.1				2	P
		Repair					0.1	4,5	Q
0110	CABLE ASSEMBLY, SPECIAL PURPOSE (W15) SCD446037	Inspect	0.1						
		Test		0.1				1	B
		Service		0.1					
		Replace		0.1				2	P
		Repair					0.1	4,5	Q
0111	CABLE ASSEMBLY, SPECIAL PURPOSE (W22)	Inspect	0.1						
		Test		0.1				1	B
		Service		0.1					
		Replace		0.1				2	P
		Repair					0.1	4,5	Q
0112	CABLE ASSEMBLY, POWER (W26) SCD690551	Inspect	0.1						
		Test		0.1				1	B
		Service		0.1					
		Replace		0.1				2	P
		Repair					0.1	4,5	Q

**Section II. MAINTENANCE ALLOCATION CHART
FOR
RADIO TELETYPEWRITER SET AN/VSC-3 AND AN/VSC-3A**

(1) GROUP NUMBER	(2) COMPONENT/ ASSEMBLY	(3) MAINTENANCE FUNCTION	(4) MAINTENANCE LEVEL					(5) TOOLS AND EQPT	(6) REMARKS
			C	O	F	H	D		
0113	CABLE ASSEMBLY, SPECIAL PURPOSE (W8) CX11016/G (6 FT)	Inspect	0.1						
		Test		0.1				1	B
		Service		0.1					
		Replace		0.1				2	P
		Repair					0.1	4,5	Q
0114	CABLE ASSEMBLY, POWER (W4, W10, W12), SCD446455	Inspect	0.1						
		Test		0.1				1	B
		Service		0.1					
		Replace		0.1				2	P
		Repair					0.1	4,5	Q
0115	CABLE ASSEMBLY POWER (W23) SCD75809	Inspect	0.1						
		Test		0.1				1	B
		Service		0.1					
		Replace		0.1				2	P
		Repair					0.1	4,5	Q
0116	CABLE ASSEMBLY, RADIO FREQUENCY (W7, W11) CG904G/U	Inspect	0.1						
		Test		0.1				1	B
		Service		0.1					
		Replace		0.1				2	P
		Repair					0.1	4,5	Q
0117	CABLE ASSEMBLY, SPECIAL PURPOSE (W3) SCD446022	Inspect	0.1						
		Test		0.1				1	B
		Service		0.1					
		Replace		0.1				2	P
		Repair					0.1	4,5	Q
0118	CABLE ASSEMBLY, RADIO FREQUENCY (W24) CG1773/U	Inspect	0.1						
		Test		0.1				1	B
		Service		0.1					
		Replace		0.1				2	P
		Repair					0.1	4,5	Q
0119	CABLE ASSEMBLY, SPECIAL PURPOSE (W1) SCD446054	Inspect	0.1						
		Test		0.1				1	B
		Service		0.1					
		Replace		0.1				2	P
		Repair					0.1	4,5	Q

SECTION IV. REMARKS

TM 11-5815-332-15

REFERENCE CODE	REMARKS
A	VISUAL INSPECTION OF EQUIPMENT AND CABLES.
B	OPERATIONAL TEST AND CONTINUITY CHECK OF CABLES ONLY.
C	ALL TESTS.
D	REPAIR BY REPLACEMENT OF FUSES, KNOBS, INTERCONNECTING CABLES, RUNNING SPARES, GROUND STRAPS, CONTROL BOX ASSEMBLY, REMOTE CONTROL BOX ASSEMBLY, AND MINOR TELETYPEWRITER COMPONENTS ONLY.
E	REPAIR BY REPLACEMENT OF COMPONENTS EXCEPT CONTROL BOX VOLTMETER.
F	REPAIR BY REPLACEMENT ONLY.
G	SEE MAC IN TM 11-5820-520-12.
H	SEE MAC IN TM 11-5805-387-15-2.
I	SEE MAC IN TM 11-5915-223-12 FOR MX-7778/GRC OR TM 11-5915-224-14 FOR MX-7778/GRC.
J	SEE MAC IN TM 11-5815-238-12.
K	SEE MAC IN TM 11-5815-200-12.
L	SEE MAC IN TM 11-5815-338-15.
M	SEE MAC IN TM 11-6125-252-15.
N	SEE MAC IN TM 11-5965-222-14P.
O	SEE MAC IN TM 11-5815-602-12.

**Section II. MAINTENANCE ALLOCATION CHART
FOR
RADIO TELETYPEWRITER SET AN/VSC-3 AND AN/VSC-3A**

(1) GROUP NUMBER	(2) COMPONENT/ ASSEMBLY	(3) MAINTENANCE FUNCTION	(4) MAINTENANCE LEVEL					(5) TOOLS AND EQPT	(6) REMARKS
			C	O	F	H	D		
0120	CABLE ASSEMBLY, AC POWER SCD960027-000	Inspect	0.1						
		Test		0.1				1	B
		Service		0.1					
		Replace		0.1				2	F,P
		Repair			0.8			4,5	Q
0121	CABLE ASSEMBLY, SPECIAL PURPOSE SCD960025-002	Inspect	0.1						
		Test		0.1				1	B
		Service		0.1					
		Replace		0.1				2	F,P
		Repair			0.8			4,5	Q
0122	CABLE ASSEMBLY, POWER SCD960024-005	Inspect	0.1						
		Test		0.1				1	B
		Service		0.1					
		Replace		0.1				2	F,P
		Repair			0.8			4,5	Q
02	CONTROL BOX ASSEMBLY SC-D-446466	Inspect		0.2					
		Test			0.5			3	
		Service		0.2				2	
		Replace			0.5				
		Repair		0.3				4,5	P
		Repair			1.0				F,Q
		Rebuild				1.0		2.0	4,5
03	REMOTE CONTROL BOX ASSEMBLY 0000	Inspect		0.2					
		Test			0.2			3	
		Service		0.2				2	
		Replace			0.5				
		Repair		0.3				2	P
		Repair			0.6				F,Q
		Rebuild				2.0			Q R
04	DUMMY BOX ASSEMBLY SC-D-446439	Inspect		0.1					
		Test			0.2			3	
		Service		0.2				2	
		Repair		0.2					
		Repair				0.5		4,5	Q
		Rebuild					2.0	4,5	

**Section II. MAINTENANCE ALLOCATION CHART
FOR
RADIO TELETYPEWRITER SET AN/VSC-3 AND AN/VSC-3A**

(1) GROUP NUMBER	(2) COMPONENT/ ASSEMBLY	(3) MAINTENANCE FUNCTION	(4) MAINTENANCE LEVEL					(5) TOOLS AND EQPT	(6) REMARKS
			C	O	F	H	D		
05	BINDING POST MOUNTING ASSEMBLY SC-B-446257	Inspect Test Service Repair	0.1 0.1		0.2 0.1			3 2 4,5	
06	RADIO SET AN/GRC-106	Replace		0.2					G
07	MODEM MD-522/GRC	Replace			0.2				H
08	ELECTRICAL TRAN- SIENT SUPPRESSOR MX-7778A/GRC	Replace		0.2					I
09	REPERFORATOR- TRANSMITTER TELETYPWRITER TT-76/GRC	Replace		0.2					J
10	TELETYPEWRITER SET TT-98/FC	Replace			2.0				K
11	LOW LEVEL SIGNAL- LING DEVICE TT-523A/GGC	Replace		0.2					L
12	MOTOR GENERATOR PU-724A/G	Replace			0.2				M
13	DYNAMIC LOUD- SPEAKER LS-166/U	Replace		0.2					N
14	TERMINAL, COMMUNICATIONS AN/UGC-74A(V)3	Replace			0.2				O

**Section III. TOOL AND TEST EQUIPMENT REQUIREMENTS
FOR
RADIO TELETYPEWRITER SET AN/VSC-3 AND AN/VSC-3A**

TOOL OR TEST EQUIPMENT REF CODE	MAINTENANCE CATEGORY	NOMENCLATURE	NATIONAL/NATO STOCK NUMBER	TOOL NUMBER
1	O	Multimeter AN/USM-105	6625-00-581-2036	
2	O	Tool Kit, Electronic Equipment TK-101/G	5180-00-064-5178	
3	F,H,D	Multimeter 3 1/2 Digit, AN/PSM-45	6625-01-139-2512	
4	F,H,D	Tool Kit, Electronic Equipment TK-100/G	5180-00-605-0079	
5	F,H,D	Tool Kit, Electronic Equipment TK-105/G	5180-00-610-8177	

Section IV. REMARKS

REFERENCE CODE	REMARKS
A	Visual inspection of equipment and cables.
B	Operational test and continuity check of cables only.
C	All tests.
D	Repair by replacement of fuses, knobs, interconnecting cables, running spares, ground straps, control box assembly, remote control box assembly, and minor teletypewriter components only.
E	Repair by replacement of components except control box voltmeter.
F	Repair by replacement only.
G	See MAC in TM 11-5820-520-12.
H	See MAC in TM 11-5805-387-15-2.
I	See MAC in TM 11-5915-223-12 for MX-7778/GRC or TM 11-5915-224-14 for MX-7778A/GRC.
J	See MAC in TM 11-5815-238-12.
K	See MAC in TM 11-5815-200-12.
L	See MAC in TM 11-5815-338-15.
M	See MAC in TM 11-6125-252-15.
N	See MAC in TM 11-5965-222-14P.
O	See MAC in TM 11-5815-602-12.
P	Retest after replacement.
Q	Retest after repair.
R	Retest after rebuild.

APPENDIX C COMPONENTS OF END ITEM LIST

SECTION 1. INTRODUCTION

C-1 . SCOPE

This appendix lists components of end item and basic issue items for the AN/VSC-3 to help you inventory items required for safe and efficient operation.

C-2. GENERAL

The Components of End Item and Basic Issue Items Lists are divided into the following sections:

a. Section II. Components of End Item. This listing is for informational purposes only, and is not authority to requisition replacements. These items are part of the end item, but are removed and separately packaged for transportation or shipment. As part of the end item, these items must be with the end item whenever it is issued or transferred between property accounts. Illustrations are furnished to assist you in identifying the items.

b. Section III. Basic Issue Items. These are the minimum essential items required to place the AN/VSC-3 in operation, to operate it, and to perform emergency repairs. Although shipped separately packaged, BII must be with the AN/VSC-3 during operation and whenever it is transferred between property accounts. The illustrations will assist you with hard-to identify items. The manual is your authority to request/requisition replacement BII, based on TOE/MTOE authorization of the end item.

C-3. EXPLANATION OF COLUMNS

The following provides an explanation of columns found in the tabular listings:

a. Column (1) - Illustration Number (Illus Number). This column indicates the number of the illustration in which the item is shown.

b. Column (2) - National Stock Number. Indicates the National stock number assigned to the item and will be used for requisitioning purposes.

c. Column (3) - Description. Indicates the Federal item name and, if required, a minimum description to identify and locate the item. The last line for each item indicates the FSCM (in parentheses) followed by the part number.

d. Column (4) - Unit of Measure (U/M). Indicates the measure used in performing the actual operation/maintenance function. The measure is expressed by a two-character alphabetical abbreviation (e.g., ea, in, pr).

e. Column (5) - Quantity required (QTY rqr). Indicates the quantity of the item authorized to be used with/on the equipment.

Section II. INTEGRAL COMPONENTS OF END ITEM

(1) Illus Number	(2) National Stock Number	(3) Description FSCM and Part Number	(4) Usable On Code U/M	(5) QTY rqr
	5820-00-223-7548	RADIO SET AN/GRC-106A C/O:		1
	5820-00-935-0033	RECEIVER-TRANSMITTER RT-834/GRC		1
	5820-00-078-4771	AMPLIFIER, RF AM-3349/GRC-106		1
	5965-00-163-9947	HANDSET H-33()/PT		1
	5965-00-226-2915	HEADSET, ELECTRICAL H-227/U		1
	5965-00-892-0722	MICROPHONE M-29B/U		1
	5805-00-503-3395	KEY, TELEGRAPH KY-116/U		1
	5995-00-177-4501	CABLE, SPECIAL PURPOSE CX-1852/U		1
	5820-00-138-8616	HARDWARE KIT FOR AN/GRC-106		1
	5820-00-089-9656	GROUNDING KIT		1
	5995-00-985-7998	CABLE, ASSEMBLY, SPECIAL PURPOSE, ELECTRICAL CX-10071/U		2
	5995-00-985-8005	CABLE ASSEMBLY SPECIAL PURPOSE ELECTRICAL CX-10099		1
	5995-00-985-8014	LEAD, ELECTRICAL CX-10171/U		1
	5995-00-578-6353	CABLE ASSEMBLY RADIO, FREQUENCY CO-4090/U		2
	5965-00-243-6420	DYNAMIC LOUDSPEAKER LS-166/J		1
	5920-00-280-4960	FUSE 2-A		
	7690-00-620-2110	DECAL		
	5985-00-892-0758	ANTENNA GROUP AN/GRA-50 C/O:		1
	5995-00-823-2176	CABLE ASEMBLY CO-687/U		1
	5985-00-893-1438	HALYARD MX-2706/G		2
	5970-00-405-8223	INSULATOR IL-4/GRA-4		1
	5895-00-896-3179	REELING MACHINE RC-432/G		2
	5985-00-757-2130	WIRE ASSEMBLY CX-7303/G		2
	5210-00-897-6077	TAPE, MEASURING		1
	6115-00-498-3973	BAG BG-175		1
		WHIP ANTENNA CONSISTING OF		
	5820-00-078-4770	MAST BASE AB-652/GR		1
	5985-00-115-7149	MAST SECTION MS-117A		1
	5985-00-199-8831	MAST SECTION MS-116A		3
	5985-00-238-7474	MAST SECTION MS-118A		1
	5820-00-497-9644	BAG CW-206/GR		1
	5935-00-259-0205	ADAPTER, CONNECTOR UG-201A/U		1
	5935-00-847-2600	ADAPTER, CONNECTOR UG-306B/U		1
	5985-00-930-7223	ANTENNA TIP ASSEMBLY		1
	5820-00-078-4769	ANTENNA COVER		1
	4020-00-073-3276	ROPE		40 FT
	5820-00-571-1828	CLAMP		1
	5340-00-694-1071	BRACKET		1
	5815-00-999-3048	LOW LEVEL SIGNAL DEVICE TT-523()/GCC		1

Section II. COMPONENTS OF END ITEM

(1) Illus Number	(2) National Stock Number	(3) Description FSCM and Part Number	(4) Usable On Code U/M	(5) QTY rqr
	6125-00-617-1435	MOTOR GENERATOR (INVERTER) PU-724/G		1
	6645-00-950-8599	CLOCK, AIRCRAFT, 8 DAY		1
	5815-00-919-4800	MODEM MD-522A/GRC		1
	5305-00-267-8983	SCREW, HEX HD 1/4-28x2 IN.		16
	5305-00-267-8983	SCREW, HEX HD 1/4-28x2 1/2 IN.		16
	5310-00-768-0319	NUT 1/4-28		16
	5310-00-889-2528	WASHER 1/4 IN.		16
	5815-00-401-9723	INSTALLATION HARNESS PPL 4785 c/o:		
	5815-00-489-6109	BRACKET ASSEMBLY (USED WITH AN/GRC-6)		1
	5815-00-489-6110	BRACKET ASSEMBLY (CONTROL BOX)		1
	5815-00-479-3031	BINDING POST MOUNTING ASSEMBLY		1
	6150-00-170-5573	BONDING JUMPER: GROUP IV (2FT 0 IN.)		1
	5815-00-222-9209	CONTROL BOX ASSEMBLY (AN/VSC-3)		1
	9905-00-484-8632	CAUTION LABEL		1
	6645-00-252-5798	CLOCK MOUNTING BRACKET ASSEMBLY		1
	5975-00-408-4997	CLAMP, SPEAKER ASSEMBLY		1
	5995-00-492-4428	CABLE SUPPORT KIT		1
	5995-00-197-6398	CABLE ASSEMBLY, SPECIAL PURPOSE, ELECTRICAL (2 FT 0 IN.) (W-1)		1
	5995-00-242-5835	CABLE ASSEMBLY, SPECIAL PURPOSE, ELECTRICAL (7 FT 0 IN.) (W-2)		1
	5995-00-252-5849	CABLE ASSEMBLY, SPECIAL PURPOSE, ELECTRICAL (7 FT 0 IN.) (W-3)		1
	5995-00-242-5833	CABLE ASSEMBLY, POWER, ELECTRICAL (5 FT 6 IN.) (W4-W12)		2
	5995-00-197-6396	CABLE ASSEMBLY, SPECIAL PURPOSE, ELECTRICAL (5 FT 0 IN.) (W-5)		1
	5995-00-195-0961	CABLE ASSEMBLY, SPECIAL PURPOSE, ELECTRICAL (5 FT 0 IN.) (W6-W7)		2
	5995-00-889-0714	CABLE ASSEMBLY, RADIO FREQUENCY CG-409G/C (6 FT 0 IN.) (W8-W11)		2
	5995-00-985-7807	CABLE ASSEMBLY, SPECIAL PURPOSE, ELECTRICAL CX-11016/G (6 FT IN.) (W-9)		1
	5995-00-195-0959	CABLE ASSEMBLY, POWER, ELECTRICAL (3FT 6 IN.) (W-10)		3
	5995-00-930-6673	CABLE ASSEMBLY, POWER, ELECTRICAL (8 FT 0 IN.) (W-13)		1
	5995-00-252-5847	CABLE ASSEMBLY, POWER, ELECTRICAL (4 FT 6 IN.) (W-14)		1
	5995-00-407-2810	CABLE ASSEMBLY, SPECIAL PURPOSE ELECTRICAL (2 Ft. 6 IN.) (W-15)		1

Section II. COMPONENTS OF END ITEM

(1) Illus Number	(2) National Stock Number	(3) Description FSCM and Part Number	(4) Usable On Code U/M	(5) QTY rqr
	5995-00-470-2233	CABLE ASSEMBLY, SPECIAL PURPOSE, ELECTRICAL CX-9994A/U (6 FT. 0 IN.) (W16-W18)		2
	5995-00-470-2232	CABLE ASSEMBLY, SPECIAL PURPOSE, ELECTRICAL CX-9995A/U (6 FT. 0 IN.) (W17-W19)		2
	5995-00-407-2811	CABLE ASSEMBLY, POWER, ELECTRICAL (2 FT. 6 IN.) (W20)		1
	5995-00-252-5850	CABLE ASSEMBLY, SPECIAL PURPOSE, ELECTRICAL (5 FT. 0 IN.) (W21)		1
	5995--00-403-5849	CABLE ASSEMBLY, SPECIAL PURPOSE, ELECTRICAL (15 FT. 6 IN.) (W22)		1
	5995-00-713-1056	CABLE ASSEMBLY, POWER "Y" (W23)		
	5995-01-403-5846	SWITCH, RCV/SEND, W/PENDENT CABLE (10 FT. 0 IN.) (W24)		1
	5995-00-823-2990	CABLE ASSEMBLY, RADIO FREQUENCY CG-1773B/U (8FT. 0 IN.) (W25)		1
	5995-00-407-2809	CABLE ASSEMBLY, POWER ELECTRICAL (9 FT. 0 IN.) (W26)		1
	5820-00-078-5615	CROSS BAR ASSEMBLY (SHORT)		2
	5820-00-226-5727	CROSS BAR ASSEMBLY (LONG)		2
	5815-00-489-6108	DUMMY, BOX ASSEMBLY		1
	5810-00-402-8390	HARDWARE KIT FOR SECURITY EQUIPMENT		1
	6130-00-448-5311	HARDWARE KIT FOR INVERTER		1
	5995-00-173-6141	GROUND STRAP ASSEMBLY (6 IN. LO.)		7
	5340-00-152-0744	HARDWARE KIT FOR RESILIENT MOUNT		1
	5820-00-078-5614	MOUNTING MT-3140/GRC-106		2
	5340-00-999-1639	MOUNTING BASE, ROBINSON TECH. INC. MODEL. W 990-3, SINGLE STAGE, 51116 OR EQUAL		1
	5340-00-903-1147	MOUNT, RESILIENT, BARRY CORP. PART NO. 83016-10 OR EQUAL		4
	9905-00-403-1022	REMOTE IDENTIFICATION TAG		1
	5815-00-933-5575	REMOTE CONTROL BOX		1
	5815-00-489-6111	R.F. SHIELD		1
	5815-00-489-6106	STORAGE BOX ASSEMBLY		1
	5915-00-937-9564	SUPPRESSOR, ELECTRICAL TRANSIENT MX-7778/GRC		1
	5970-00-188-5477	TAPE, ELECTRICAL, 3/4 IN. WIDE		1
	5815-00-489-6107	TELETYPEWRITER TAPE STORAGE BIN		1
	5815-00-403-1042	TABLE ASSEMBLY, SHOCK MOUNT, FOR TT-98D/FG		1
	5815-00-403-1043	TABLE ASSEMBLY, SHOCK MOUNT, FOR TT-76D/GGC		1
	9905-00-484-8634	WARNING PLATE		1
	9905-00-484-8633	WARNING LABEL		1
	5120-00-129-1475	WRENCH SET ALLEN		1

Section II. COMPONENTS OF END ITEM

(1) Illus Number	(2) National Stock Number	(3) Description FSCM and Part Number	(4) Usable On Code U/M	(5) QTY rqr
	5815-00-503-2764	TELETYPEWRITER TT-90(*)/FG C/O:		1
	3020-00-203-1327	GEAR, WORM 100 WPM		1
	3020-00-203-1678	GEAR, WORM 60 WPM		1
	3020-00-351-7944	GEAR, SPUR 100 WPM		1
	5815-00-898-7279	GEAR, SPUR 60 WPM		1
	5815-00-356-3371	SHAFT, ASSEMBLY		1
	5815-00-356-3227	SPOOL PRINTING RIBBON		1
	7510-00-082-2648	RIBBON		1
	7530-00-223-7966	PAPER		1 ROLL
	5815-00-663-3066	CRANK		1
	5815-00-553-6061	REPERFORATOR-TRANSMITTER TT-76(*)/GGC C/O:		1
	3020-00-203-1327	GEAR, WORM 100 WPM		1
	3020-00-203-1678	GEAR, WORM 60 WPM		1
	3020-00-351-7944	GEAR, SPUR 100 WPM		1
	5815-00-898-7279	GEAR, SPUR 60 WPM		1
	5815-00-224-9717	TUNING FORK		1
	5815-00-356-3227	SPOOL, PRINTING RIBBON		1
	7510-00-082-2648	RIBBON		1
	5815-00-219-7010	CLIP		1
	7530-00-634-6237	TAPE, TELETYPE		1
	5815-00-392-7813	CHAD BIN		1
	5815-00-392-7822	BRACKET		1
	5305-00-983-6649	SCREW		4
	5310-00-596-6895	NUT		4
	5310-00-809-8544	WASHER		4
	5815-00-672-6727	TEMPLATE, BENCH		1
	5815-01-102-5916	TERMINAL, COMMUNICAITONS AN/UGC-74A(V)3		1
	5815-01-088-3328	INSTALLATION KIT AN/VSC-3A		1

Section III. BASIC ISSUE ITEMS

(1) Illus Number	(2) National Stock Number	(3) Description FSCM and Part Number	(4) Usable On Code U/M	(5) QTY rqr
		<u>RUNNING SPARE PARTS</u>		
	5920-00-581-4144	FUSE 2A (FOR TT-76(*)/GGC)		
	5920-00-043-2641	FUSE 1/4A (FOR TT-98(*)/FG)		
	5920-00-229-1312	FUSE 1/16A (FOR TT-98(*)/FG)		
	5920-00-228-7882	FUSE 2A (FOR TT-98(*)/FG)		
	6240-00-143-3084	LAMP, INCANDESCENT 115V 15W		
	6135-00-120-1020	BATTERY BA-30		4
	5120-00-129-1475	WRENCH SET ALLEN		
	5815-00-402-5308	ACCESSORY KIT MK-1506/VSC-3 ²		4
	6135-00-120-1020	BATTERY BA-30 ¹ (SEE AAL)		1
	7520-00-281-5918	CLIP BOARD 9 IN. WIDE X 12 1/2 IN. LONG		1
	7105-00-269-8463	CHAIR, FOLDING, METAL FOLDING		1
	5340-00-407-7299	CHAIR LEG EXTENSION KIT		1
	5815-00-403-1040	DUST COVER FOR TT-98/FG		1
	5815-00-933-5566	DUST COVER FOR TELETYPEWRITER SECURITY DEVICE		1
	6230-00-729-9614	FLASHLIGHT, WALL LANTERN (4 CELL)		1
	NO NSN REQ.	RADIO TELETYPEWRITER SET AN/VSC-3 INSTALLED IN CARRIER, COMMAND POST M577A1		
	7510-00-082-2648	RIBBON, PRINTING TELETYPEWRITER, COTTON RIBBON, GRADE A, HEAVY INKING		2
	7530-00-223-7966	PAPER, TELETYPEWRITER: 8 1/2 IN. WD.		1
	5120-00-223-7397	PLIERS, SLIP JOINT		1
	5815-00-403-1041	DUST COVER FOR TT-76C/GGC		1
	5905-00-156-6690	RESISTOR ASSEMBLY 5600 WITH SPACE LUG TERMINAL		1
	5120-00-222-8852	SCREWDRIVER 6 IN. FLAT TIP, 1/4 SHANK		1
	7530-00-634-6237	TAPE, BLANK, RECORDING: TELETYPEWRITER 0 875 IN WD, 8 IN. O.D., 2 IN. ID, OILED		1
		¹ DRY BATTERIES ARE NOT PACKAGED WITH SUBJECT EQUIPMENT AND ARE TO BE REQUISITIONED IN ACCORDANCE WITH INSTRUCTIONS CONTAINED IN SUPPLY BULLETIN SB-11-6, SUBJECT "DRY BATTERY SUPPLY DATA"		
		² APPLICABLE PUBLICATIONS: TM 11-5805-387-15-2, TM 11-5815-200-12, TM 11-5815-238-12, TM 11-5815-332-15, TM 11-5815-338-15 TM 11-5815-616-13.		

APPENDIX D

ADDITIONAL AUTHORIZATION LIST

Section I. INTRODUCTION

D-1. Scope

This appendix lists additional items you are authorized for the support of the AN/VSC-3.

D-2. General

This list identifies items that do not have to accompany the AN/VSC-3 and that do not have to be turned in with it. These items are all authorized

to you by CTA, MTOE, TDA, or JTA.

D-3. Explanation of Listing

National stock numbers, descriptions, and quantities are provided to help you identify and request the additional items you require to support this equipment.

(Next printed page is D-2)

APPENDIX E

EXPENDABLE SUPPLIES AND MATERIALS LIST

Section I. INTRODUCTION

E-1. Scope

This appendix lists expendable supplies and materials you will need to operate and maintain the AN/VSC-3. These items are authorized to you by CTA 50-970, Expendable Items (Except Medical, Class V, Repair Parts, and Heraldic Items).

E-2. Explanation of Columns

a. *Column 1—Item Number.* This number is assigned to the entry in the listing and is referenced in the narrative instructions to identify the material (e.g., “Use cleaning compound, item 6, app D”).

b. *Column 2—Level.* This column identifies the lowest level of maintenance that requires the listed item.

O—Organizational Maintenance

c. *Column 3—National Stock Number.* This is the National stock number assigned to the item; use it to request or requisition the item.

d. *Column 4—Description.* Indicates the Federal item name and, if required, a description to identify the item. The last line for each item indicates the part number followed by the Federal Supply Code for Manufacturer (FSCM) in parentheses, if applicable.

e. *Column 5—Unit of Measure (U/M).* Indicates the measure used in performing the actual maintenance function. This measure is expressed by a two-character alphabetical abbreviation (e.g., ea, in, pr). If the unit of measure differs from the unit of issue, requisition the lowest unit of issue that will satisfy your requirement.

(Next printed page is E-2)

SECTION II EXPENDABLE SUPPLIES AND MATERIALS LIST

(1) ITEM NO.	(2) LEVEL	(3) NATIONAL STOCK NUMBER	(4) DESCRIPTION PART NO. AND FSCM	(5) UNIT OF MEAS
	0	7530-00-223-7966	PAPER, TYPEWRITER	QT
	0	7510-00-082-2648	RIBBON, PRINTING TELETYPEWRITER	
	0	7530-00-634-6237	TAPE, TELETYPEWRITER PAPER	
	0	8305-00-267-3015	CLEANING CLOTH, LINT FREE	
	0	5350-00-264-3485	SANDPAPER NO. 000	
	0	6850-00-105-3084	TRICHLOROTRIFLOUROETHANE	

GLOSSARY

Compatible AM:	When a receiver is capable of receiving single sideband and carrier signals.
CVC:	Combat vehicle crewman.
Ics:	Intercommunications set.
NSK:	Teletypewriter information which shifts a 2000 Hz signal ± 42.5 Hz.
FSK:	Teletypewriter information which shifts a 2000 Hz signal ± 425 Hz.
Pony circuit:	Teletypewriter communications over a landline, between the M577A1 and a remote site.

INDEX

	Paragraph	Page		Paragraph	Page
Additional equipment required	1-9	1-15	Operational tests	7-5b(2)	7-1
Antenna description	1-7e	1-16	Organization:		
Antenna installation	2-4	2-4	Troubleshooting	5-4	5-2
Antijamming	3-17	3-13	Troubleshooting chart	5-4c	5-3
Cable connections	2-2	2-1	Pendent plug	3-3	3-3
Cabling chart	2-2b	2-1	Pony circuit operation	3-14c	3-12
Cable repair	7-10	7-8	Power distribution	6-3	6-1
Characteristics, technical.....	1-5	1-2	Preliminary operating procedures:		
Checking received equipment..	2-1	2-1	Control box	3-8a	3-7
Circuit functioning	6-1	6-1	MX-7778/GRC	3-8b	3-7
■ Cleaning	4-4	4-4	Radio Set AN/GRC-106	3-8c	3-7
Component description	1-8	1-8	Teletypewriter Reperforator-		
Connectors, remote control	3-3	3-3	Transmitter TT-76(*)/GGC	3-8f	3-7
Control box:			Teletypewriter Set TT-98(*)/FG	3-8e	3-7
Connectors	3-2	3-1	Preparation for vehicle movement	3-18	3-13
Continuity tests	7-14	7-15	Publication indexes	1-2	1-1
Controls	3-2	3-1	Purpose and use	1-4	1-1
Indicator	3-2	3-1	Monthly maintenance	5-3	5-1
Maintenance	7-9	7-8	Radio Set AN/GRC-106(*)		
Replacement	7-3	7-1	starting procedure	3-10	3-8
Voltage Tests	7-13	7-15	Recognition of jamming	3-16	3-12
Curbside description	1-7e	1-6	Records, forms and	1-3	1-1
CVC helmet	3-6	3-6	Remote:		
DA Pam 310-4	1-2a	1-1	Control box controls.	3-3	3-3
DA Pam 310-7.	1-2b	1-1	Control box replacement	7-3	7-1
Depot overhaul standards	8-1	8-1	Operation	1-10b,3-14	1-18,3-9
Description of system	1-7	1-4	Stopping procedure	3-14d	3-12
Direct support cable and switch maintenance	7-2	7-1	Teletypewriter operation	3-14b	3-11
Direct support maintenance..	7-1	7-1	Removal of damaged antenna		
DOS test procedures	8-2	8-1	mast sections	5-5	5-3
Dummy box connector	3-4	3-3	Removal of security equipment	2-5b	2-4
Dummy box replacement	7-3	7-1	Repairing AN/VSC-3 components	7-11	7-8
Electrical transient suppressor.	3-5	3-6	Replacement of damaged antenna		
Forms and records	1-3	1-1	mast sections	5-5	5-3
Functioning of			Roadside:		
Signal circuits	6-2	6-1	Shelf description	1-7b	1-4
Teletypewriter dc signal circuit	6-2b	6-1	Table description	1-7d	1-6
Voice and cw circuits	6-2a	6-1	Wall description	1-7c	1-6
General instructions	7-4	7-1	scope	1-1	1-1
General power requirements	1-5a	1-2	Scope of circuit functioning	6-1	6-1
General support:			Scope of operators maintenance.	4-1	4-1
Maintenance	7-4	7-1	Sectionalization	7-5b	7-1
Testing	7-12	7-15	Siting	2-3	2-4
Troubleshooting chart	7-8	7-5	Starting procedure AN/VIC-1(V)....	3-11	3-8
Troubleshooting procedures.	7-5	7-1	Stopping procedures	3-13	3-9
Identification of jamming	3-16	3-12	Suppressor, electrical transient	3-5	3-6
Indexes	1-2	1-1	System application	1-10	1-18
Indicator, control box	3-2	3-1	Technical characteristics	1-5	1-2
Installation of security equipment	2-5a	2-4	Teletypewriter starting procedures	3-9	3-7
Intercommunication set	3-6	3-6	Test equipment required	7-6	7-2
Isolation	7-5c	7-1	Trichloroethane	4-3b	4-2
Localization	7-5c	7-1	Turning procedures Radio Set		
Local operation	3-12, 1-10a	3-8,1-18	AN/GRC-106(*)	3-10	3-8
Operating position:			Unusual teletypewriter operation.	3-15	3-12
Crew commanders.	3-6b	3-6	Use of general support		
Driver	3-6c	3-6	troubleshootin chart	7-7	7-2
Teletypewriter	3-6c	3-6	Use, purpose	1-4	1-1
Operating procedures, preliminary	3-8	3-7	Vehicle movement, preparation for	3-18	3-13
Operator's maintenance	4-1	4-1	Visual inspection	7-5b(1)	7-1
Organizational maintenance....	5-1	5-1			

By Order of the Secretary of the Army:

Official:

**KENNETH G. WICKHAM,
Major General, United States Army,
The Adjutant General.**

**W. C. WESTMORELAND,
General, United States Army,
Chief of Staff**

Distribution :

To be distributed in accordance with DA Form 12-51 (qty rqr Block # 646), Organizational maintenance requirements for AN/VRC-29 radio teletypewriter act; DA Form 12-37 (qty rqr Block # 182), Organizational maintenance requirement for M577, M577A1 Command Post Vehicle.

☆ U.S. GOVERNMENT PRINTING OFFICE : 1988 O - 201-421 (80208)

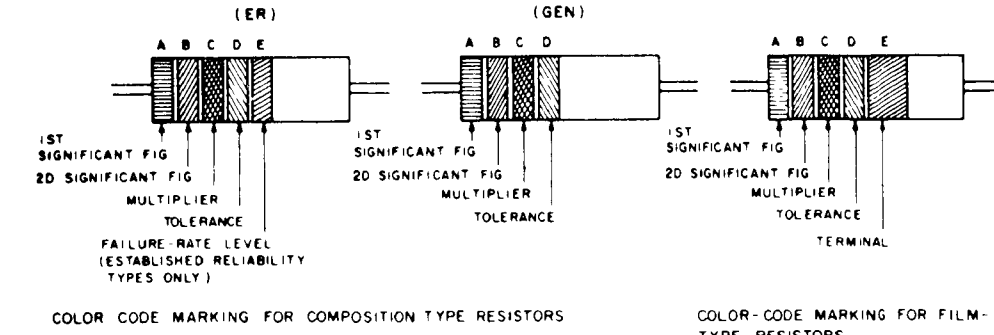

TABLE 1
COLOR CODE FOR COMPOSITION TYPE AND FILM TYPE RESISTORS

BAND A		BAND B		BAND C		BAND D		BAND E	
COLOR	FIRST SIGNIFICANT FIGURE	COLOR	SECOND SIGNIFICANT FIGURE	COLOR	MULTIPLIER	COLOR	RESISTANCE TOLERANCE (PERCENT)	COLOR	FAILURE RATE LEVEL
BLACK	0	BLACK	0	BLACK	1	BROWN	±10	BROWN	M=0
BROWN	1	BROWN	1	BROWN	10	RED	±1	RED	P=0.1
RED	2	RED	2	RED	100	ORANGE	±5	ORANGE	R=0.01
ORANGE	3	ORANGE	3	ORANGE	1,000	YELLOW	±2 (NOT APPLICABLE TO ESTABLISHED RELIABILITY)	YELLOW	S=0.001
YELLOW	4	YELLOW	4	YELLOW	10,000	SILVER	±5 (COMP TYPE ONLY)	WHITE	
GREEN	5	GREEN	5	GREEN	100,000	GOLD			SOLD-ERABLE
BLUE	6	BLUE	6	BLUE	1,000,000	RED			
PURPLE (VIOLET)	7	PURPLE (VIOLET)	7						
GRAY	8	GRAY	8	SILVER	0.01				
WHITE	9	WHITE	9	GOLD	0.1				

BAND A — THE FIRST SIGNIFICANT FIGURE OF THE RESISTANCE VALUE (BANDS A THRU D SHALL BE OF EQUAL WIDTH.)

BAND B — THE SECOND SIGNIFICANT FIGURE OF THE RESISTANCE VALUE

BAND C — THE MULTIPLIER (THE MULTIPLIER IS THE FACTOR BY WHICH THE TWO SIGNIFICANT FIGURES ARE MULTIPLIED TO YIELD THE NOMINAL RESISTANCE VALUE.)

BAND D — THE RESISTANCE TOLERANCE

BAND E — WHEN USED ON COMPOSITION RESISTORS, BAND E INDICATES ESTABLISHED RELIABILITY FAILURE-RATE LEVEL (PERCENT FAILURE PER 1,000 HOURS) ON FILM RESISTORS THIS BAND SHALL BE APPROXIMATELY 1/2 TIMES THE WIDTH OF OTHER BANDS AND INDICATES TYPE OF TERMINAL RESISTANCES IDENTIFIED BY NUMBERS AND LETTERS (THESE ARE NOT COLOR CODED)

SOME RESISTORS ARE IDENTIFIED BY THREE OR FOUR DIGIT ALPHA NUMERIC DESIGNATORS THE LETTER R IS USED IN PLACE OF A DECIMAL POINT WHEN FRACTIONAL VALUES OF AN OHM ARE EXPRESSED FOR EXAMPLE

2R7 = 2.7 OHMS 10R0 = 10.0 OHMS

FOR WIRE-WOUND-TYPE RESISTORS COLOR CODING IS NOT USED. IDENTIFICATION MARKING IS SPECIFIED IN EACH OF THE APPLICABLE SPECIFICATIONS

EXAMPLES OF COLOR CODING

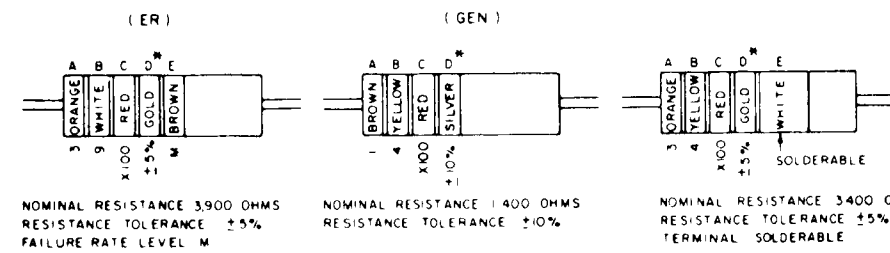

COMPOSITION-TYPE RESISTORS

FILM-TYPE RESISTORS

IF BAND D IS OMITTED THE RESISTOR TOLERANCE IS ±20% AND THE RESISTOR IS NOT MIL-STD

A COLOR CODE MARKING FOR MILITARY STANDARD RESISTORS

B COLOR CODE MARKING FOR MILITARY STANDARD INDUCTORS

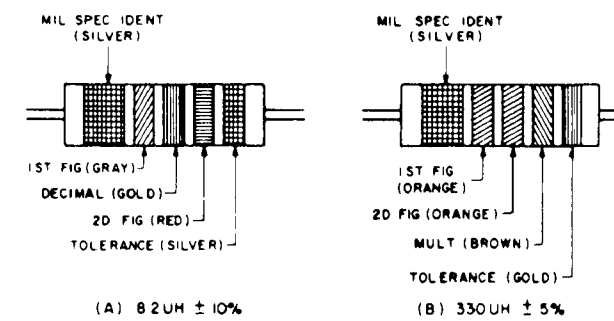

COLOR CODING FOR TUBULAR ENCAPSULATED RF CHOKES AT A, AN EXAMPLE OF OF THE CODING FOR AN 8.2 uH CHOKE IS GIVEN AT B, THE COLOR BANDS FOR A 330 uH INDUCTOR ARE ILLUSTRATED

TABLE 2
COLOR CODING FOR TUBULAR ENCAPSULATED RF CHOKES

COLOR	SIGNIFICANT FIGURE	MULTIPLIER	INDUCTANCE TOLERANCE (PERCENT)
BLACK	0	1	
BROWN	1	10	1
RED	2	100	2
ORANGE	3	1,000	3
YELLOW	4		
GREEN	5		
BLUE	6		
VIOLET	7		
GRAY	8		
WHITE	9		
NONE			20
SILVER			10
GOLD		DECIMAL POINT	5

MULTIPLIER IS THE FACTOR BY WHICH THE TWO COLOR FIGURES ARE MULTIPLIED TO OBTAIN THE INDUCTANCE VALUE OF THE CHOKE COIL

CAPACITORS, FIXED, VARIOUS-DIELECTRICS, STYLES CM, CN, CY, AND CB

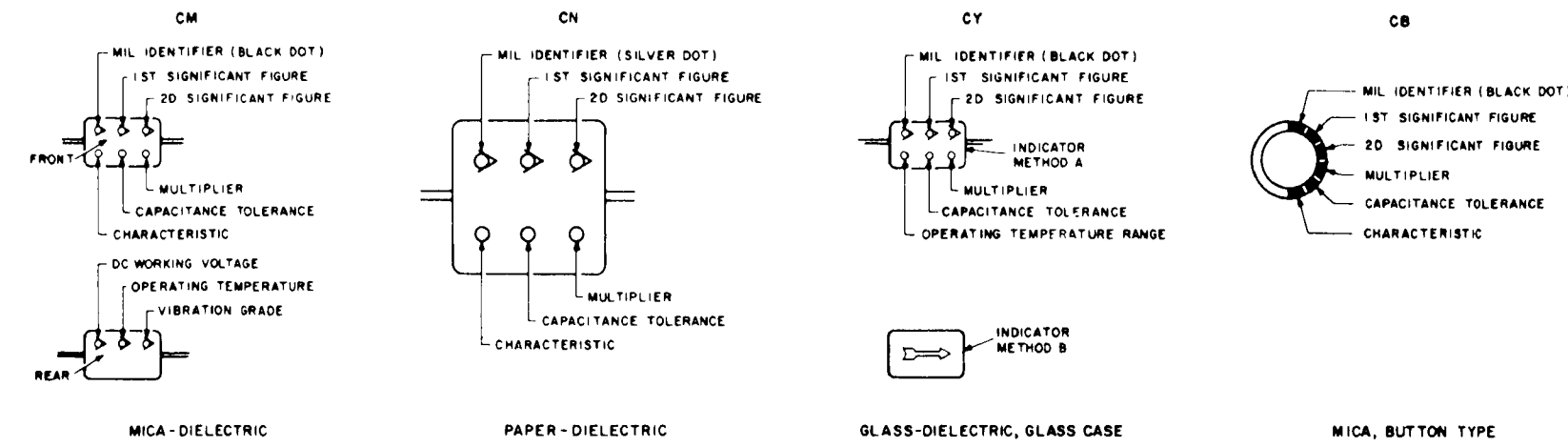

TABLE 3 — FOR USE WITH STYLES CM, CN, CY AND CB

COLOR	MIL ID	1ST SIG FIG	2D SIG FIG	MULTIPLIER	CAPACITANCE TOLERANCE				CHARACTERISTIC	DC WORKING VOLTAGE	OPERATING TEMP RANGE	VIBRATION GRADE
					CM	CN	CY	CB				
BLACK	CM, CN, CB	0	0	1			±20%	±20%	A		-55° TO +70°C	10-55 Hz
BROWN		1	1	10					B	E		
RED		2	2	100	±2%		±2%	±2%	C			
ORANGE		3	3	1,000	±30%				D	D	300	
YELLOW		4	4	10,000					E			
GREEN		5	5		±5%				F		500	
BLUE		6	6									
PURPLE (VIOLET)		7	7									
GRAY		8	8									
WHITE		9	9									
GOLD				0.1			±5%	±5%				
SILVER	CN			0.01	±10%	±10%	±10%	±10%				

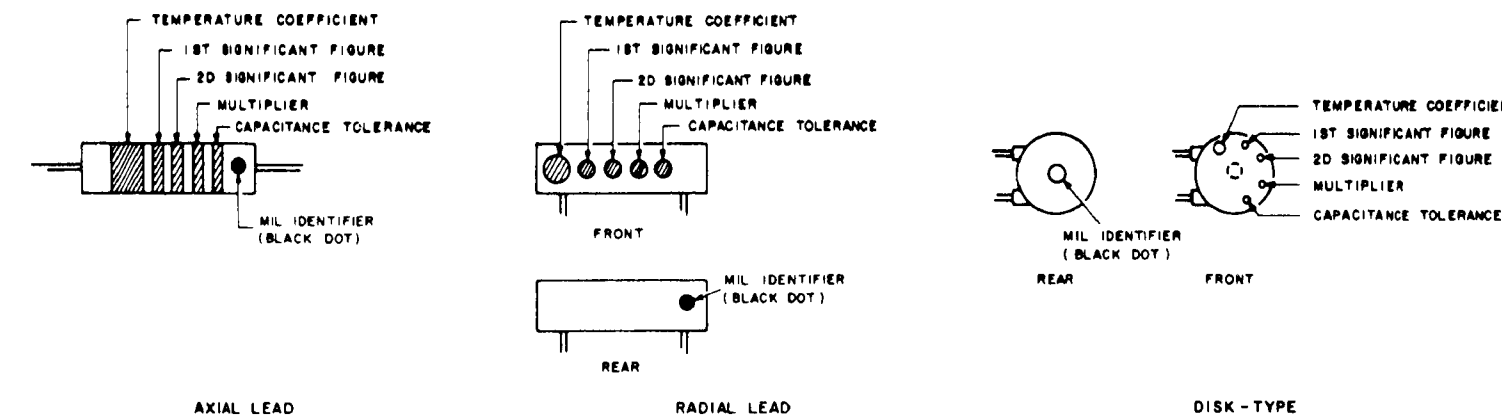

TABLE 4 — TEMPERATURE COMPENSATING, STYLE CC

COLOR	TEMPERATURE COEFFICIENT	1ST SIG FIG	2D SIG FIG	MULTIPLIER	CAPACITANCE TOLERANCE		MIL ID
					CAPACITANCES OVER 10 uUF	CAPACITANCES 10 uUF OR LESS	
BLACK	0	0	0	1		±10 uUF	CC
BROWN	-30	1	1	10	±1%		
RED	-80	2	2	100	±2%	±0.85 uUF	
ORANGE	-150	3	3	1,000			
YELLOW	-220	4	4				
GREEN	-330	5	5		±3%	±0.5 uUF	
BLUE	-470	6	6				
PURPLE (VIOLET)	-750	7	7				
GRAY		8	8	0.01*			
WHITE		9	9	0.1*	±10%		
GOLD	+100			0.1		±10 uUF	
SILVER				0.01			

- THE MULTIPLIER IS THE NUMBER BY WHICH THE TWO SIGNIFICANT (SIG) FIGURES ARE MULTIPLIED TO OBTAIN THE CAPACITANCE IN uUF
- LETTERS INDICATE THE CHARACTERISTICS DESIGNATED IN APPLICABLE SPECIFICATIONS MIL-C-5, MIL-C-25D, MIL-C-11272B, AND MIL-C-10950C RESPECTIVELY
- LETTERS INDICATE THE TEMPERATURE RANGE AND VOLTAGE-TEMPERATURE LIMITS DESIGNATED IN MIL-C-11015D
- TEMPERATURE COEFFICIENT IN PARTS PER MILLION PER DEGREE CENTIGRADE
- OPTIONAL CODING WHERE METALLIC PIGMENTS ARE UNDESIRABLE

C COLOR CODE MARKING FOR MILITARY STANDARD CAPACITORS

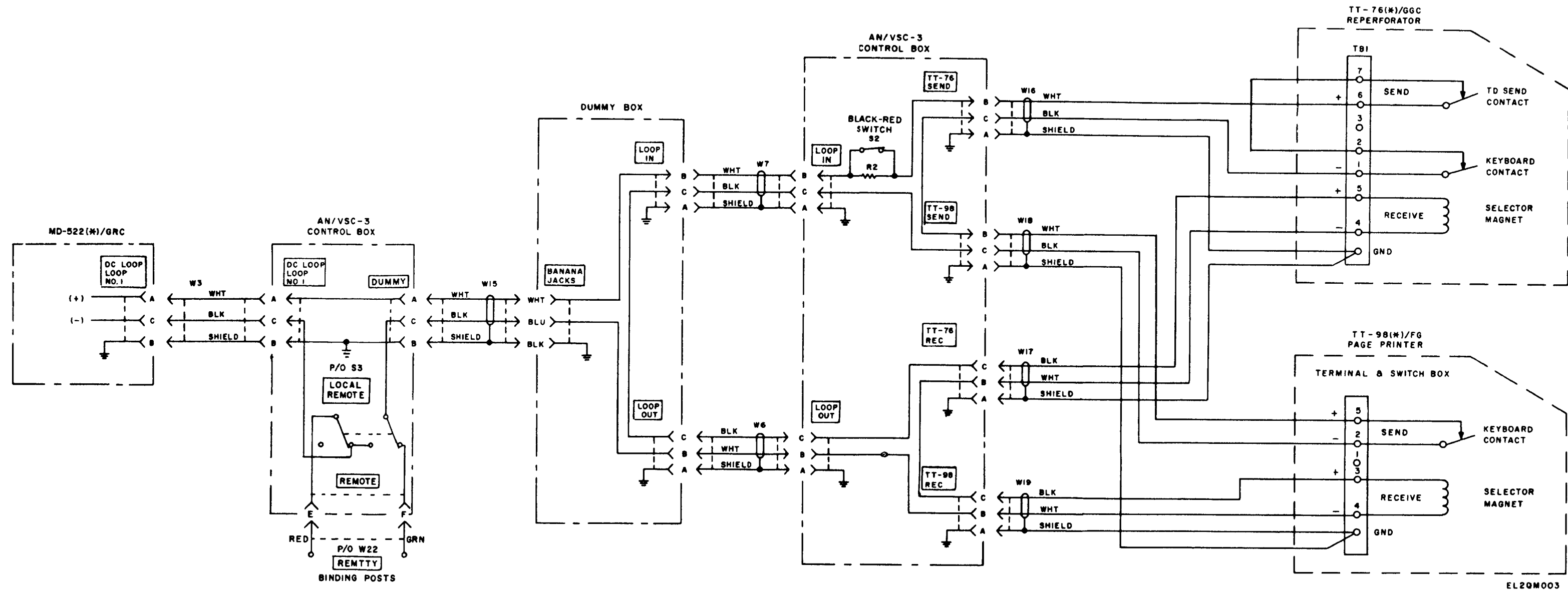
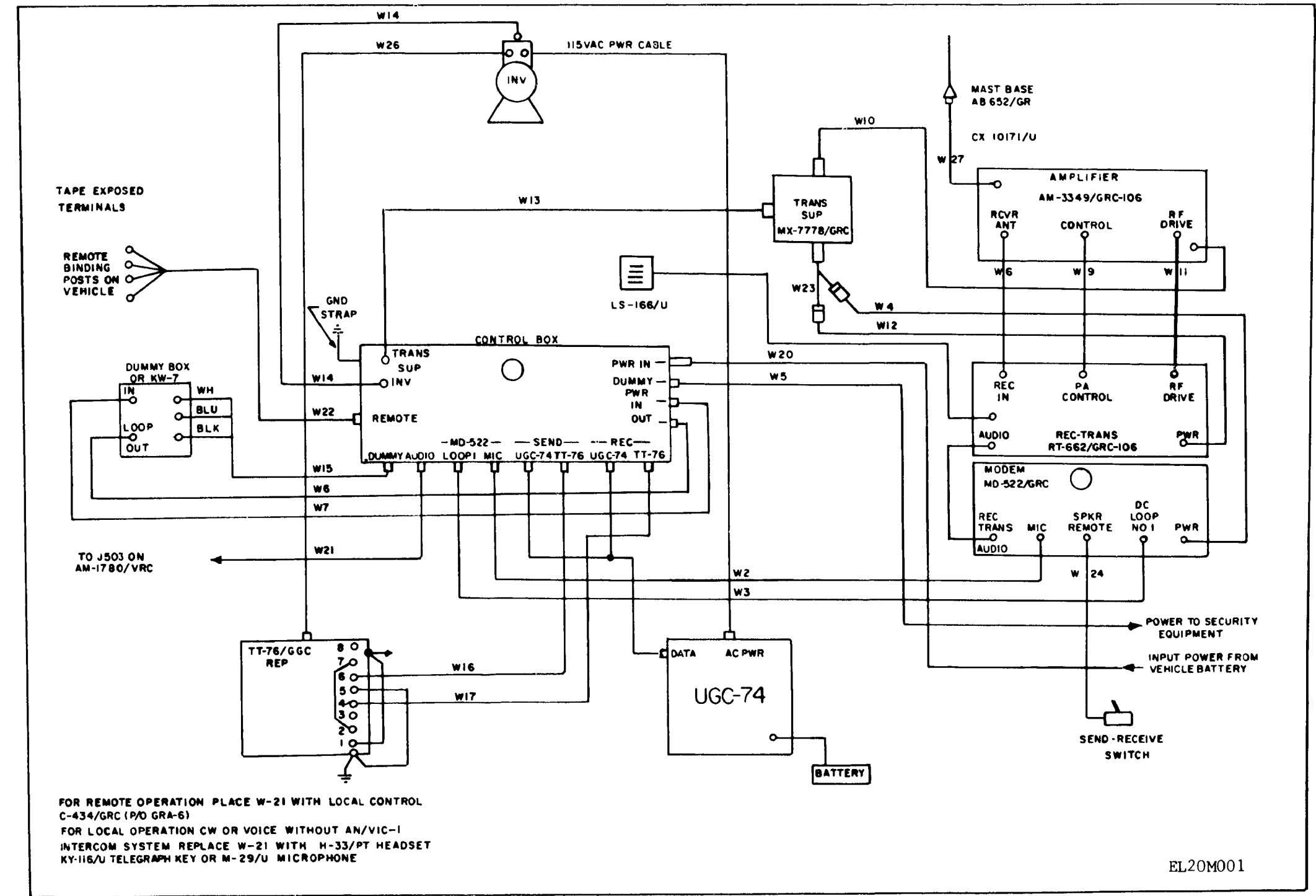
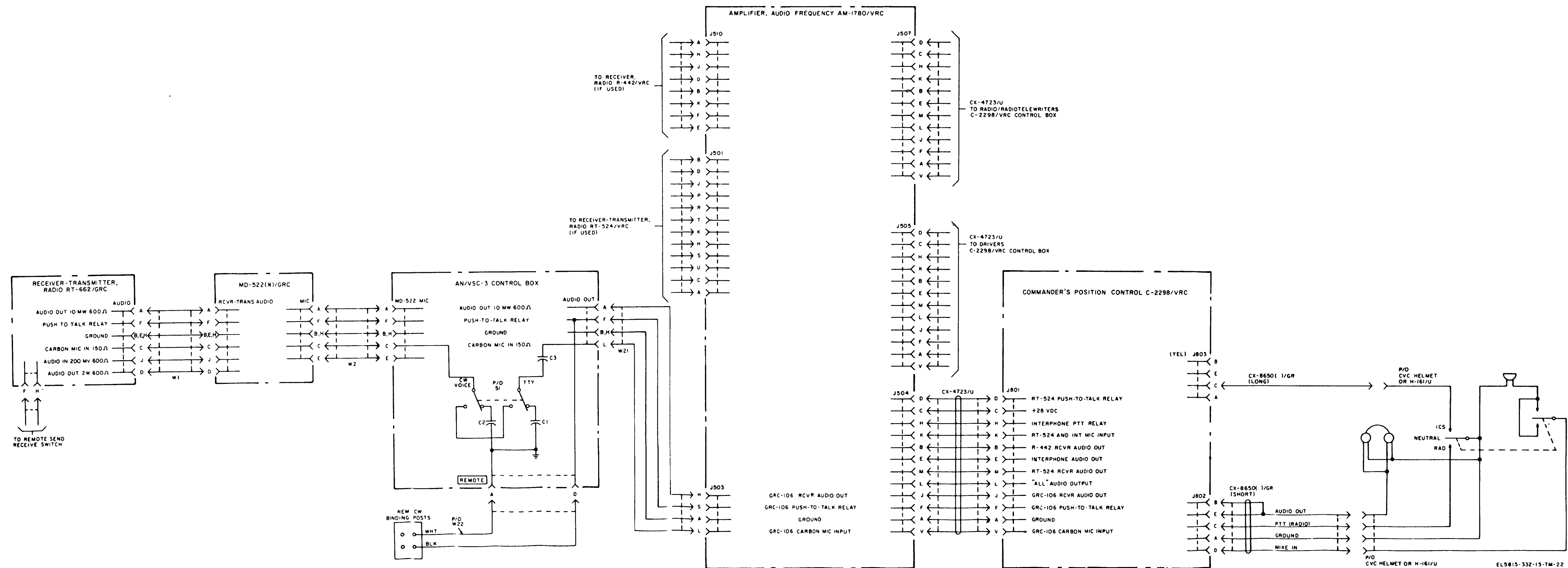

Figure FO 2. Teletypewriter dc signal circuit.



EL20M001

Figure FO 2-1.1 Cabling diagram, ANVSC-3A.



FO-3. Voice and cw signal circuits.

